



Application Catalogue

Number 54 | August 2023

OME Features

NITROCHARGER SPORT SHOCK ABSORBERS

LARGE BORE 35MM TWIN TUBE DESIGN

Allows greater oil volume for cooling and sustained valving performance and strong 1.6mm outer tube construction protects the vital internal components from damage.

LARGE 18MM HARDENED CHROME PISTON ROD

Strong enough to handle any load or harsh conditions expected from your 4x4.

TRIPLE LIP CHECK VALVE OIL SEAL – MK2

The latest technology in oil seal design – physically larger with quantum improvements in durability, oil and gas retention with much greater resistance to heat so it keeps working under the harshest conditions.

TEFLON-IMPREGNATED LOW FRICTION ROD GUIDE

The latest refinement in rod guide design further reduces heat build-up and maintains performance.

TEFLON-INFUSED BRONZE ROD GUIDE SLIP RING

A new component that maintains consistent and uniform performance by providing a tight and uniform fit between the piston rod and rod guide.

MULTI DEFLECTIVE DISC VALVING SYSTEM

A unique and new valving system that features multiple disc valving control at the base of the shock and on both sides of the piston rod. This allows the OME engineers more valving options for better ride quality and handling control.

35MM HIGH FLOW TEFLON-BANDED PISTON

New low friction design has less restrictive oil flow through the piston, reduces heat build-up and aeration of the oil that leads to fade.

VEHICLE-SPECIFIC VALVING

OME shock absorbers performance stand head and shoulders over its competitors because many hours of OME engineering valving work have been put into each and every shock absorber to ensure our customers get the best ride and handling their vehicle can have.

POLYETHYLENE DIRT SHIELD

Impact-resistant, polyethylene dirt shield provides additional protection from stone chips and off road debris.

NITROGEN GAS

Increases the temperature operating range and improves oil flow through the valving, ensuring optimum performance.

SUPPLEMENTARY WELDS

For strength and reliability, all mounts have supplementary welds.

NITROCHARGER SHOCK ABSORBERS

GIANT 18MM CHROMED SHAFT

Indestructible for Australia's rugged off roading. Induction hardened then hard chromed to a superfine finish.

NITROGEN GAS

The gas pressure keeps the oil cohesive under all situations.

TWIN TUBE DESIGN

33% thicker outer tube insures that rocks do not damage internal operating components. This design also allows for a greater volume of oil, which keeps the shock cooler.

35MM SEVEN STAGE COMPRESSION VALVE

Delivers all the subtleties of compression rates for the best ride and handling.

CHECK VALVE SEAL

The latest in seal technology, this shaft seal significantly improves gas retention whilst offering excellent longevity.

GLACIER BUSH

A Teflon-coated rod guide bush significantly reduces heat build-up in the rod guide area, developed from the Emu's off road racing program.

GIANT 35MM TEFLON-BANDED PISTON

A new four-stage coil-sprung rebound valve system to control vehicle bounce.

SUPPLEMENTARY WELDS

On all mounting eyes and pins for maximum shock absorber mount strength.

STONEGUARD

Protects oil seal and piston rod against stone and dirt damage.

X5K MICRO-ALLOYED SPRING STEEL

New generation high strength spring steel grade designed to withstand higher operating stresses with superior resistance to sag and improved toughness and corrosion fatigue properties.

COIL SPRINGS

SHOT-PEENED

To reduce stress, which greatly enhances spring life.

DOUBLE-SCRAGGED

To eliminate spring sag.

VARIABLE AND CONSTANT RATE

Designs used to obtain optimum ride comfort and load-carrying capabilities.

COIL SPRUNG 9 STAGE VALVING

For optimum performance.

STEERING STABILISERS

35MM PISTON & BORE

Greater oil volume giving better damper performance.

TWIN TUBE DESIGN

Protects the internal components against stone damage.

STEEL STONEGUARD

Protects the piston rod against stone damage.

FOAM CELL

Keeps the oil at the valving to prevent fade.

ORIGINAL MOUNTS

All mounts are of similar design to original stabilisers for ease of fitment.

LEAF SPRINGS

FLAT AXLE SEAT AREA

Lowers spring stress whilst retaining spring-free camber height. Unique to most OME springs.

ANTI-FRICTION INTERLEAF LINERS

Used where applicable to reduce friction between spring leaves, giving better ride comfort and increased spring life.

SHOT-PEENED

On the tension side of all leaves to double spring life.

DRAW-TAPERED & DIAMOND CUT LEAVES

For reduced interleaf friction and improved load distribution in the load-bearing area.

GRAPHITE-COATED

For further reduced friction.

MILITARY-WRAPPED

For extra safety (where fitment permits).

LOOSE-CLAMPED

For smooth and quiet operation.

URETHANE BUSHES - LEAF SPRING

PREMIUM GRADE

Not all bushes are the same - OME bushes are precision moulded in captive moulds to ensure exact tolerances for long bush life.

SPLINES

Ensures the best fit by taking up irregularities in spring eyes.

UNIQUE OME DESIGN

Clever lip seal and shoulder design prevents dirt penetrating between bush shoulder and shackle face.

GREASEABLE SHACKLES

REDUCED WEAR

Greasable shackles reduce shackle pin deterioration, increase bush life, enable easy maintenance and improve ride and handling.

ANTI-INVERSION FACILITY

Built-in feature on all LandCruiser greaseable shackles.

SERVICING

Simple and effective.

WARRANTY

For a copy of ARB's Warranty Policy, ARB Products: Warranty Against Defects, please visit the ARB website.

www.arb.com.au

	PAGE
GUIDE TO SELECTION	3
NITROCHARGER SPORT SELECTION	4
NITROCHARGERS & STEERING STABILISER APPLICATIONS	11
COMPACT AWD - OME SPRING & SHOCK ABSORBER RANGE	16
GVM UPGRADES.....	17
GVM UPGRADES - HISTORICAL REFERENCE.....	32
 SUSPENSION APPLICATIONS	
ARMOURED APPLICATIONS	64
CHRYSLER / JEEP	66
FORD	87
HOLDEN / ISUZU / GM / GMC / CHEVROLET	106
HUMMER	118
HYUNDAI	119
KIA	120
LADA.....	121
LAND ROVER	122
MAZDA	130
MERCEDES-BENZ	135
MITSUBISHI	136
NISSAN	152
SSANGYONG	176
SUZUKI	177
TOYOTA	186
VOLKSWAGEN	246
 TECHNICAL SPECIFICATIONS	
SUSPENSION BUSH KIT SELECTION	249
DIAGRAM REFERENCE FOR SUSPENSION BUSH KITS	256
NUMERICAL SPRING & SHOCK / STRUT BUSH APPLICATIONS	258
OLD MAN EMU POLYURETHANE SPRING BUSH DIMENSIONS	263
SUSPENSION FITTING KITS	265
LEAF SPRING SERVICE PARTS	273
REPLACEMENT MAIN OR SECOND LEAF	278
U BOLTS	279
REPLACEMENT CENTRE BOLTS	281
LEAF SPRING CENTRE BOLT SLEEVES	277
LEAF SPRING SPECIFICATIONS	282
COIL SPRING SPECIFICATIONS	286
BP-51 SPECIFICATIONS	295
BP-51 SPARE PARTS	297
MT-64 SPECIFICATIONS.....	299
NITROCHARGER PLUS SPECIFICATIONS	300
NITROCHARGER SPORT SPECIFICATIONS	305
NITROCHARGER SPECIFICATIONS	310
SHOCK ABSORBER MOUNT TYPE	315
TORSION BAR SPECIFICATIONS	315
STEERING STABILISER SPECIFICATIONS	316
RECOMMENDED FITTING TIMES	317
FIT TIMES BY VEHICLE	318

© ARB Corporation Limited, Old Man Emu Division P.O. Box 105 Kilsyth, Vic. 3137 Australia.

All rights reserved. No part of this catalogue may be reproduced or copied in any form or by any means (graphic, electronic or mechanical, including photocopying, recording, taping or information systems) without the written permission of the publisher.

Terminologies & Explanations

Please note most suspension development has been carried out on Australian specification models. Therefore, some differences may exist between the same model in another country. Overseas customers will need to make allowances for these possible differences.

Supplying all items shown on suspension selection charts will ensure the system can be fitted, however, there will be vehicles which will not require all items, eg. trimming kits, caster kits, all U bolts shown, etc. Actual, individual vehicle requirements can only be determined when the suspension system is fitted.

Vehicle Region:

Domestic (AUS)	Indicates the suspension was developed in Australia on an Australian vehicle, compatibility outside of Australia will need to be confirmed.
International (USA)	Indicates the suspension was developed in the USA on a USA vehicle, compatibility outside the USA will need to be confirmed.
Global	Indicates the suspension was developed in Australia on a Global platform, it is still recommended to confirm compatibility outside of Australia.

GVM - GROSS VEHICLE MASS: Set by the vehicle manufacturer and is determined by brake, axle, differential and tyre specifications. Exceeding GVM ratings can have legal and safety implications and is not recommended.

LOAD RATING:

FRONT: Weights shown are maximum permissible loads with regard to accessories fitted, eg. Bull bar, winch, dual battery, etc.

REAR: The explanations below indicates the passenger and load weights that will provide optimum ride and handling.

LIGHT LOAD: Full passenger load with luggage weights up to 150kg.

MEDIUM LOAD: Full passenger load with luggage weight varying from 200kg to 350kg.

HEAVY LOAD: Full passenger load with luggage weight varying from 350kg to 500kg.

CONSTANT LOAD: The minimum constant load shown on selection chart is required for optimum spring performance.

Please note: These loads are approximate only. Refer to individual vehicle selection for load specifications.

LIFT HEIGHT: Is shown as a guide only and equates to the amount of lift over the vehicle's original ride height. This amount can vary from vehicle to vehicle.

OE: Original Equipment, as supplied by the manufacturer of the vehicle.

***SHOCK ABSORBERS*:** Where two part numbers are given for the same application the part with the asterisk (*) indicates the shock absorber with the firmer ride.

SPRING BUSH: OME polyurethane spring eye bushes on installation must only be greased in the bore and on the flange area and regularly thereafter with OME polyurethane grease.

STEERING STABILISER: Designed as a larger capacity replacement for the OE part and incorporates 50/50 neutral valving.

CASTER KIT: The OMECA77B, CALR1 and CALR2 kits consist of 4 eccentric bushes which are pressed into the leading arms of the vehicle. This will induce positive caster into the front geometry.

LEAF SPRINGS: A & B springs can be used to compensate for uneven vehicle weight distribution. Springs marked "A" have a greater camber height than springs marked 'B'. 'A' type springs are generally fitted to the driver's side and 'B' springs to the passenger side. Where two spring rates are listed for one spring the spring is progressive.

COIL SPRINGS: A & B springs are used to compensate for uneven vehicle weight distribution. 'A' type springs are generally higher in free high than the 'B' spring. Individual coil specifications are listed in the back of this publication. Where two spring rates are listed for one spring the spring is progressive.

GEARBOX PACKER KIT: Designed to space down the gearbox cross member from the chassis to reduce tail shaft flange angle thereby reducing driveline vibration.

GREASABLE SHACKLES: Replacement for original shackles allow easy regular greasing of polyurethane spring eye bushes.

TRIM PACKERS: The prime purpose of a trim packer is to correct slight vehicle leaning.

VEHICLES WITH LEAF SPRINGS UNDER SLUNG: Trim packer when fitted will reduce suspension height.

VEHICLES WITH LEAF SPRINGS OVER SLUNG: Trim packer when fitted will increase suspension height.

VEHICLES WITH COIL SPRINGS: Polyurethane trim packer main purpose is to correct slight vehicle trimming problems and will increase ride height when fitted.

NITROCHARGER SPORT SELECTION

SELECTION ADVICE

Where there is a choice of part numbers it is important the right selection is made with consideration given to type of spring rates and customer applications.

Firm Valving

The firm part number should be selected whenever heavy rate springs are fitted, as the valving has been specifically developed to control the higher spring rates. The firmer valving will provide better control when cornering, while also preventing axle bounce over rough roads.

If a softer valved selection is fitted with a heavy rate spring the vehicle's rebound handling will be reduced. This will be evident by axle bounce over rough roads, dipping under braking or cornering and wallowing over undulating roads.

Soft Valving

Valved specifically for light to medium rate springs. Most suitable for customers wanting a comfortable ride and regularly carry light to medium loads. Under full GVM load a slight amount of body roll during cornering and highway speed manoeuvring can occur.

A RECOMMENDATION FOR CUSTOMERS BUYING 4 REPLACEMENT SHOCK ABSORBERS

By the time a customer has decided to replace the old and well used original shock absorbers there is every chance that the original springs are also ready for replacement.

It should be explained to the customer that if their springs are sagged and tired that this would cause the shock absorbers to work a lot harder.

Therefore, the life expectancy of the shock absorbers will be considerably shortened and, when loaded, ride and handling qualities will also be reduced.

REMEMBER: A good set of shock absorbers will not overcome a bad set of springs.

YEAR	VEHICLE DESCRIPTION	OME NITROCHARGER SPORT SHOCKS & STRUTS		STEERING STABILISERS
		FRONT	REAR	
CHRYSLER JEEP				
	Dodge RAM 1500 DS	90044 ¹¹	*60165 ³⁹ / 60164 ³⁹	
2016 on	Grand Cherokee WK2	90035 ⁵ LHS 90036 ^{5,12} RHS	60124 ⁵ /60125 ⁵ / 60152 ^{5,12} /60153 ^{5,12}	
2016 to 2017	Grand Cherokee WK2	90035 ⁵ LHS 90036 ^{5,12} RHS	60124 ⁵ /60125 ⁵ / 60126 ^{5,12} /60127 ^{5,12}	
2011 to 2015	Grand Cherokee WK2	90026 ⁵	60124 ⁵ /60125 ⁵ / 60126 ^{5,12} /60127 ^{5,12}	
1999 to 2004	Grand Cherokee WJ & WG	60087	60088	
All	Grand Cherokee ZJ	60092	60093	OMESD40
2008 to 2013	Cherokee/Liberty KK All Models	90009 ¹¹	60069	
2002 to 2007	Cherokee/Liberty KJ All Models (OME Springs)	90009 ¹¹	60069	
1984 to 2001	Cherokee XJ - Petrol & Diesel	60052	60053	OMESD40 ⁹
2018 on	Wrangler JL SWB 3.6L Petrol Engine Model	*60162 ¹² / 60160 ¹²	*60163 ¹² / 60161 ¹²	
	Wrangler JL LWB 3.6L Petrol & 2.2L Diesel Engines			
	Wrangler JL SWB Sport & Rubicon Models	60150 ^{12,34,35}	60151 ^{12,34}	
	Wrangler JL LWB Sport & Rubicon Models	60150 ^{12,34,35}	60151 ^{12,34}	
2006 to 2017	Wrangler JK All Models Off Road Use ONLY ³²	60066M ¹² (mid Length)/ 60066L ¹² (long)	60067L ¹²	OMESD48
2006 to 2017	Wrangler JK - All Models	60066 ¹²	60067 ¹²	OMESD48
1997 to 2006	Wrangler TJ	*60047 ¹² / 60046 ¹²	*60049 ¹² / 60048 ¹⁰	OMESD40 ⁹
1986 to 1996	Wrangler YJ	60098	60099	OMESD40
DAIHATSU				
1992 to 1997	Feroza II F310	60040	N/A	
1988 to 1992	Feroza I F300	60040	N/A	
1993 on	Rocky F78 Wide Track	60031 ¹²	N/A	OMESD31 ¹² '86 on
FORD				
2022 on	Everest MY22.00	*90053 ^{12,17} / 90052 ^{12,17}	*60175 ^{12,16} /60174 ^{12,16}	
2018 to 2022	Everest MY19	*90039 ^{12,17} / 90038 ^{12,17}	*60145 ¹⁶ / 60144 ¹⁶	
2015 to 2018	Everest	*90020 ^{12,17} / 90019 ^{12,17}	*60145 ¹⁶ / 60144 ¹⁶	

Cont.

NITROCHARGER SPORT SELECTION

OME NITROCHARGER SPORT SHOCKS & STRUTS

STEERING STABILISERS

YEAR	VEHICLE DESCRIPTION	FRONT	REAR	
FORD (continued)				
2021 on	Bronco LWB	90047 ¹⁷	90048 ¹⁷	
	Ranger (USA model only)	90040 ¹¹	*60157 / 60156	
2022 on	Ranger MY22.00	*90053 ^{12,41} / 90052 ^{12,41}	*60173 ¹² /60172 ¹² *60178 ^{12,42} /60173 ¹²	
2018 to Mid 2022	Ranger PXIII	*90038 ^{12,23} / 90039 ^{12,23}	*60102 ¹² / 60101 ¹² *60101 ¹² / 60023 ¹²	
2011 to 2018	Ranger PXI & PXII	*90020 ^{12,33} / 90019 ^{12,13}	*60102 ¹² / 60101 ¹² *60101 ¹² / 60023 ¹²	
12/06 to 2011	Ranger PJ/PK All Models	60022 ²⁶	*60102 ¹² / 60023 ¹²	
2011 to 2017	F250 & F350 Diesel	60123 / 60121 ¹⁵	60122	
2008 to 2010	F250 & F350 Diesel	60123 / 60121 ¹⁵	60122	
1985 to 2005	Courier/Ranger Pick Up not USA manufactured model	60022 ⁴	60023 ¹²	
1987 to 1993	Raider Wagon	60022	60023 ¹²	
All	Maverick Wagon & Hard Top	*60013 ¹² / 61012 ¹²	*60015 ^{12,39} /61014 ^{12,39}	to 8/89 OMESD34 9/89 on OMESD36
HOLDEN/GM/ISUZU/CHEVROLET/GMC				
2017 on	Trailblazer	*90023 ^{12,17} / 90022 ^{12,17}	*60131 ¹⁸ / 60130 ¹⁸	
2021 on	MU-X	*90046 ^{12,17} / 90045 ^{12,17}	*60131 / 60130	
2013 to 2020	MU-X	*90023 ^{12,17} / 90022 ^{12,17}	*60131 ¹⁸ / 60130 ¹⁸	
2013 to 2016	Colorado 7	*90023 ^{12,17} / 90022 ^{12,17}	*60131 ¹⁸ / 60130 ¹⁸	
2015 on	GMC/Colorado / Canyon Gas & Diesel Engines (USA)	*90037 ³⁷	60148 ³⁷ / 60149 ³⁷	
2012 on	GM Pick Up Models - Colorado	*90023 ^{12,13} / 90022 ^{12,13}	*60117 ¹² / 60116 ¹²	
2008 to 2011	GM/Isuzu Pick Up Models Colorado RC / DMAX	60031 ¹²	*60064 ¹² / 60032 ¹²	
2021 on	Isuzu Pick Up Models - DMAX	*90046 ^{12,13} / 90045 ^{12,13}	*60168 ¹² / 60167 ¹²	
2012 to 2020	Isuzu Pick Up Models - DMAX	*90023 ^{12,13} / 90022 ^{12,13}	*60117 ¹² / 60116 ¹²	
2003 to 2011	Rodeo Pick Up RA Models	60031 ¹²	*60064 ¹² / 60032 ¹²	
7/81 to 2003	Rodeo/Isuzu Pick Up KB4, KBD4 & TFS	60031 ¹²	*60064 ¹² / 60032 ¹²	
1992 to 2004	Jackaroo/Trooper & Monterey (Isuzu Wagon)	60031 ¹²	60074	
11/86 to 3/92	Jackaroo/Trooper	60031 ¹²	*60063 ⁸ / 60009 ⁸ *60064 ¹² / 60032 ¹²	
1982 to 10/86	Jackaroo/Trooper	60031 ¹²	*60064 ¹² / 60032 ¹²	
99 to 6/2003	Frontera Wagon	60031 ¹²	N/A	
1995 to 1998	Frontera UT	60031 ¹²	60074	
HUMMER				
7/2007 on	H3	90001	60045	
HYUNDAI				
To 4/1991	Gallop (Rear Leaf Springs)	60051	*60036 ¹² / 60057	
1989 to 5/91	Gallop (Rear Coil Springs) NF & NG	60051	60056	
2001 on	Terracan V6	60040	60060	
2005 on	Terracan Diesel	60040	60060	
LAND ROVER				
1999 to 2004	Discovery Series II (Not Suitable for Airbag Models)	60024 ¹²	60025 ¹² / 60026 ¹²	OMESD02
1991 to 1999	Discovery Series I	60037 ¹²	60039 ¹² /60038 ¹² 60147 ^{12,29} /60146 ^{12,29}	OMESD11
to 5/1995	Range Rover (Not Suitable for Airbag Models)	60037 ¹²	60039 ¹² /60038 ¹² 60147 ^{12,29} /60146 ^{12,29}	OMESD11
	Defender 110	60037 ^{12,28,29}	60039 ¹² /60038 ¹² 60147 ^{12,33} /60146 ^{12,33}	OMESD32
1984 on	90 Series	60037 ^{12,28,29}	60039 ¹² /60038 ¹² 60147 ^{12,33} /60146 ^{12,33}	OMESD32
	Defender 130	60037 ^{12,28,29}	60039 ¹² 60147 ^{12,33}	OMESD32

Cont.

NITROCHARGER SPORT SELECTION

YEAR	VEHICLE DESCRIPTION	OME NITROCHARGER SPORT SHOCKS & STRUTS		STEERING STABILISERS
		FRONT	REAR	
LAND ROVER (continued)				
1984 on	Defender & County 110	*60070 ^{12,27,29} /60018 ^{12,27,29}	*60070 ^{12,27} /60018 ^{12,27}	OMESD32
MAZDA				
2021 on	Mazda BT50	*90046 ^{12,13} / 90045 ^{12,13}	*60168 ¹² / 60167 ¹²	
2011 to 2020	Mazda BT50	*90020 ^{12,33} / 90019 ^{12,13}	*60101 ¹² / 60023 ¹² *60102 ¹² / 60101 ¹²	
2006 to 2011	Mazda BT50 All Models	60022 ⁴	*60102 ¹² / 60023 ¹²	
1987 to 2006	B2600 Pick Up All Models	60022 ⁴	60023 ¹²	
MERCEDES				
	G-Wagon G350 Bluetech / G55 AMG Models	60113	60114	
MITSUBISHI				
2015 on	Pajero Sport All Diesel Models	90008 ^{12,19}	*60075 ¹² / 60076	
2007 on	Pajero All LWB Models	*90007 ^{12,13} /90006 ^{12,13}	60033 ¹² / 60019 ¹²	
2007 on	Pajero All SWB Models	90007 ^{12,13} / 90006 ^{12,13}	60033 ¹² / 60019 ¹²	
2000 to 10/06	Pajero All LWB Models	*90007 ^{12,13} /90006 ^{12,13}	60033 ¹² / 60019 ¹²	
4/00 to 2006	Pajero/Montero NS, NM, NP & NT LWB & SWB	90007 ^{12,13} / 90006 ^{12,13}	60033 ¹² / 60019 ¹²	
91 to 3/2000	Pajero/Montero (R Coil Springs) NH, NJ, NK, NL (S/LWB)	60040	60041	
	Pajero/Montero (R Leaf Springs) NH, NJ, NK, NL (S/LWB)	60040	*60036 ¹² / 60057	
89 to 5/1991	Pajero/Montero Sport (Rear Coil Springs) NF & NG	60051	60056	
to 4/1991	Pajero/Montero (Rear Leaf Springs) NA, NB, NC, ND, NE, NF & NG	60051	*60036 ¹² / 60057	
2009 to 2015	Challenger/Montero Sport KH	90008 ^{12,13}	*60075 ¹² / 60076	
2000 to 2008	Challenger/Montero Sport (Rear Coil Springs) LWB	60040	60059	
1998 to 2000	Challenger V6/Montero Sport (Rear Leaf) Wagon PA	60040	*60036 ¹² / 60057	
2018 on	Triton/L200 MR	90031 ^{12,19} / 90033 ^{12,19}	*60140 ^{12,20} /60139 ¹² *60139 ¹² /60138 ¹²	
2015 to 2018	Triton/L200 MQ All 4x4 Models	90031 ^{12,19} / 90033 ^{12,19}	*60140 ^{12,20} /60139 ¹² *60139 ¹² /60138 ¹²	
7/06 to 2015	Triton/L200 ML & MN All Models	90008 ^{12,13}	60036 ¹²	
10/96 to 6/06	Triton/L200 MK All Models	60040	60050	
93 to 9/1996	Triton/L200 MJ All Models	60051	60058	
91 to 8/1996	Triton/L200 V6 (OE Springs)	60051	60057	
10/86 to 1993	Triton/L200 (V6 & 4 Cylinder) ME, MF, MG, MH	60051	60058	
to 1986	L200 MA, MB, MC & MD	60051	60058	
to 9/1986	L300 Vans SA, SB, SC & SD	60051	60032 ¹²	
NISSAN				
2010 on	Patrol Y62 (Non HBMC Models)	*90015 ¹¹ / 90014 ¹¹	60084	
02/2000 on	Patrol Y61 (GU) SWB & Wagon	60013 ¹² / 61012 ¹²	60015 ¹² / 61014 ^{3,12}	OMESD01
1997 on	Patrol Y61 (GU) LWB Off Road Use ONLY ^{31, 32}	60013L ¹²	60015L ¹²	1/00 on OMESD01 pre 1/00 OMESD11
1997 on	Patrol Y61 (GU) CC (Coil Front/Leaf Spring Rear)	60055	60054	OMESD11
	Patrol Y61 (GU) Cab Chassis (All Coil Springs)	60013 ¹² / 61012 ¹²	60015 ¹² / 61014 ^{3,12}	OMESD11
97 to 1/2000	Patrol Y61 (GU) Wagon & SWB	60013 ¹² / 61012 ¹²	60015 ¹² / 61014 ^{3,12}	OMESD11
9/1989 on	Patrol Y60 (GQ) Wagon, SWB & Cab Chassis	60013 ¹² / 61012 ¹²	60015 ¹² / 61014 ¹²	OMESD36
to 8/1989	Patrol Y60 (GQ) Wagon & SWB	60013 ¹² / 61012 ¹²	60015 ¹² / 61014 ¹²	OMESD34
9/1989 on	Patrol Y60 (GQ) LWB, SWB & CC Suits LPG Conversion	60013 ¹² / 61012 ¹²	61014 ¹²	OMESD36
to 8/1989	Patrol Y60 (GQ) Wagon & SWB Suits LPG Conversion	60013 ¹² / 61012 ¹²	61014 ¹²	OMESD34
from 1988	Patrol Y60 (GQ) LWB Off Road Use ONLY ^{31, 32}	60013L ¹²	60015L ¹²	8/89 on OMESD36 pre 8/89 OMESD34
88 to 7/1997	Patrol Y60 (GQ) Ute & Cab Chassis (Leaf Springs)	60068	60054	OMESD22
2005 to 2014	Pathfinder R51 (not USA manufactured model)	90003 ^{12,13}	60016 ¹²	
86 to 8/1995	Pathfinder/Terrano WD21	60031 ¹²	*60064 ¹² / 60032 ¹²	OMESD35 ¹²
2005 on	Navara D40 / Frontier (USA)	90003 ^{12,13}	*60110 ¹² / 60017 ¹²	

Cont.

NITROCHARGER SPORT SELECTION

OME NITROCHARGER SPORT SHOCKS & STRUTS

STEERING STABILISERS

YEAR	VEHICLE DESCRIPTION	FRONT	REAR	
NISSAN (continued)				
2019 on	Navara D23 NP300 (Leaf Spring Rear)	90032 ^{12,13}	*60135 ¹² / 60134 ¹²	
Series 4 & 5	Navara D23 NP300 (Coil Spring Rear)	90032 ^{12,13}	*60137 ^{6,12} 60136 ^{6,12}	
2015 to 2018	Navara D23 NP300 (Leaf Spring Rear)	90032 ^{12,13}	*60135 ¹² / 60134 ¹²	
Series 1, 2, 3	Navara D23 NP300 (Coil Spring Rear)	90032 ^{12,13}	*60137 ^{6,12} 60136 ^{6,12}	
2008 to 2014	NP300 All Models	60034 ²	60035	
10/2002 on	Navara D22 All Models	60034 ²	60035	
1/86 to 8/02	Navara D21 & D22 Pick Up	60021 ²	60035	OMESD35 ¹²
1/1986 on	Navara D21 & D22 Pick Up 4x2	60040 ²	N/A	
1980 to 1985	720 Ute & Cab Chassis	60040 ²	*60064 ¹² / 60032 ¹²	
1996 to 2005	Terrano II R20	60031 ^{2,12}	60058	
1996 to 1999	Terrano II 4x4 (European Models)	60031 ¹²	60058	
2005 on	Xterra	90003 ^{12,13}	60017 ^{12,14}	
SSANGYONG				
1995 to 2005	Musso, Sport Utility & Korando Models	60031 ¹²	N/A	
SUZUKI				
2009 on	Equator (US Market Only)	60031 ¹²	60017 ¹²	
2018 on	Jimny (4th Gen) 4 Cyl. 1.5L Petrol Engine All Models	60154 ¹²	60155 ^{12,38}	
TOYOTA				
08/2021 on	LandCruiser 300 Series, GX, GXL, VX, SAHARA V8 Diesel Engine & Petrol Engine Not AVS Models	*90055 ^{11,12,40} / 90054 ^{11,12,40}	*60177 ^{1,12} / 60176 ^{1,12}	
07 to 07/2021	LandCruiser 200 Series V8 Not AHC Models	91005 ^{12,13,40} / 90017 ^{12,13,40}	61030 ^{1,12} / 61029 ^{1,12}	
3/1998 on	LandCruiser 100 Series (IFS) Not AHC Models	*60001 ¹² / 60000 ¹²	*60003 ^{1,12} / 60002 ^{1,12}	
from 04/1990	LandCruiser 105 & 80 Series (Front Live Axle)	*60070 ¹² / 60018 ¹²	60071 ^{1,12} / 60020 ^{1,12}	OMESD24
	LC 105 & 80 Series (Front Live Axle) LPG conversion	*60070 ¹² / 60018 ¹²	60020 ^{1,12}	OMESD24
	LandCruiser 80 & 105 Series Off Road Use ONLY ^{31, 32}	60018L ¹² / 60070L ¹²	60020L ¹² / 60071L ¹²	OMESD24
4/90 to 1998	LandCruiser 80 Series	*60070 ¹² / 60018 ¹²	60071 ^{1,12} / 60020 ^{1,12}	OMESD24
2009 on	Prado 150 Series LWB (Coil Spring Models Only)	90010 ^{12,13}	*60081 ^{1,12} / 60080 ^{1,12}	
	Prado 150 Series SWB (Coil Spring Models Only)	*90010 ^{12,13} / 90016 ¹³	*60080 ^{1,12} / 60086 ^{1,12}	
4/03 to 2009	Prado 120 Series LWB, SWB (Not TEMS/Grande Models)	*90000 ^{12,13} / 90021 ¹³	*60005 ^{1,12} / 60004 ^{1,12} / *60004 ^{1,12} / 60112 ^{1,12}	
7/96 to 10/02	Prado 95 & KZJ90 Series	90004 ¹²	*60027 ^{1,12} / 60028 ^{1,12}	
2007 on	LandCruiser 78 & 79 Series SC 6 Cyl. Petrol, Diesel & V8 Diesel Models Not 1GR-FE Models	60008 ¹²	60011 ¹² / 60010 ¹² / 60109 ¹²	OMESD47
1999 to 2006	LandCruiser 78 & 79 Series SC - 6 Cylinder Petrol & Diesel Models Not 1GR-FE Models	60008 ¹²	60011 ¹² / 60010 ¹² / 60109 ¹²	OMESD24
2007 on	LandCruiser 76 Series Wagon - V8	60008 ¹²	*60111 ^{1,12} / 60011 ^{1,12} / 60010 ^{1,12}	OMESD47
1985 to 1999	LandCruiser 75 Series Not 1GR-FE Models	60063 / 60009	60011 ¹² / 60010 ¹²	OMESD24
All	LandCruiser 70 Series Dual Cab Not 1GR-FE Models	60008 ¹²	60109 ¹² / 60010 ¹² / 60011 ¹²	OMESD24 6 Cyl. OMESD47 V8 Dsl.
1985 on	LandCruiser 70, 73 & 74 Series SWB & MWB	60009	60062 ¹²	OMESD24
to 2007	LandCruiser HZJ71 & HJZ74 Series SWB & MWB	60008 ¹²	60044 ¹²	OMESD24
All	LandCruiser II Wagon LWB	60089	60090	
1984 to 1990	Bundera RJ70	60094	60096 RHS 60095 LHS	
1986 to 3/90	LandCruiser 60,61 & 62 Series (Rear Lower Pin 19mm)	60063 / 60009	*60065 / 60062 ¹²	OMESD24
1980 to 1986	LandCruiser 60 Series (Rear Lower Pin 16mm)	60063 / 60009	*60064 ¹² / 60032 ¹²	OMESD24
All	LandCruiser 45 - 47 Series All LWB Models	60097	60064 ¹² / 60032 ¹²	OMESD23
	LandCruiser 40 - 42 Series SWB	60097	*60064 ^{12,21} / 60032 ^{12,21}	OMESD23
2010 on	FJ Cruiser	*90010 ^{12,13} / 90016 ¹³	*60081 ^{1,12} / 60080 ^{1,12} / *60080 ^{1,12} / 60086 ^{1,12}	

Cont.

NITROCHARGER SPORT SELECTION

OME NITROCHARGER SPORT SHOCKS & STRUTS

STEERING STABILISERS

TOYOTA (continued)				
2006 to 2010	FJ Cruiser	*90000 ^{12,13} / 90021 ¹³	*60004 ^{1,12} / 60112 ^{1,12} 60081 ^{1,12}	
2015 on	Fortuner	90028 ^{12,13} / 90029 ^{12,13}	60141 ^{12,22} / 60142 ^{12,22}	
2004 to 2015	Fortuner	*90002 ^{12,13} / 90011 ^{12,13}	60078 ¹² / 60077 ¹²	
2015 on	HiLux All Models	90028 ^{12,13} / 90029 ^{12,13}	*60133 ¹² / 60132 ¹²	
2005 to 2015	HiLux Vigo KUN26R, GGN25R	*90002 ^{12,13} / 90011 ^{12,13}	60007 ¹² / 60006 ¹²	
9/97 to 2004	HiLux Tiger LN172, LN167, KZN165, RZN174 & RZN169 (IFS)	60042	60044 ¹² LHS 60043 ⁷ RHS	OMESD33
9/83 to 8/97	HiLux LN65, YN65, LN106, RN105 (All Leaf Suspension)	60061	*60065 / 60062 ¹²	OMESD21
to 8/1983	HiLux LN46 & RN46 (All Leaf) (Rear Lower Pin 16mm)	60061	*60064 ¹² / 60032 ¹²	OMESD21
1988 to 8/97	HiLux/4 Runner LN107, RN105, RN110 & LN111 (IFS)	60072	60065	OMESD33
to 1997	HiLux (IFS) Rear Leaf Springs	60072	60065	OMESD33
2016 on	Tacoma	*90000 ^{12,13} / 90021 ¹³	60091 ¹²	
2005 to 2015	Tacoma V6	*90000 ^{12,13} / 90021 ¹³	60091 ¹²	
1998 to 2004	Tacoma V6 & 4 Cylinder Models	90004 ¹²	*60065 / 60062 ¹²	
2007 on	Tundra	90018 ^{11,12}	60100 ¹²	
2010 on	4 Runner (USA)	90010 ^{12,13}	*60081 ^{1,12} / 60080 ^{1,12}	
2003 to 2010	4 Runner (USA)	90000 ^{12,13}	*60005 ^{1,12} / 60004 ^{1,12}	
1996 to 2002	4 Runner/Surf Front & Rear Coil Springs (USA)	90004 ¹²	*60027 ¹² / 60028 ¹²	
1990 to 1996	4 Runner (IFS) Front Torsion Bar/Rear Coil Springs	60072	60073	OMESD33
9/83 to 8/97	4 Runner (All Leaf Suspension)	60061	*60065 / 60062 ¹²	OMESD21
to 8/1983	4 Runner (All Leaf Suspension) (Rear Lower Pin 16mm)	60061	*60064 ¹² / 60032 ¹²	OMESD21
1986 to 1990	4 Runner (IFS) Rear Leaf Springs	60072	60065	OMESD33
VOLKSWAGEN				
2010 on	Amarok 4 Cylinder Diesel	90013 ^{23,24,30,36} / 90012 ^{23,24,30,36}	60083 ²⁵ / 60082 ²⁵	
	Amarok V6 Diesel	90013 ^{23,24,30,36}	60083 ²⁵ / 60082 ²⁵	

NOTES: *first part number has firmer valving.

1. Shock lower body stone guards are recommended fitment to rear shocks to protect against severe stone pepping encountered on loose road surfaces. OME661 (suits Sorento BL To 09, FJ Criser 06 On, 4 Runner 10 On & 03 to 10 USA models, LandCruiser 76 LWB, 80, 100, 105, 200, 300 Series, Prado 150 09 on coil sprung not Kakadu, 120 Series 10/02 to 09 not TEMS & Prado 90 Series to 10/2002 LWB). OME662 (suits LandCruiser 105 & 80 Series with 34mm diameter Control Arm, 100 Series IFS not AHC with 40mm diameter Control Arm). OME660 (suits all other models).
2. It may be necessary to slightly increase the clearance in the front wishbone to allow the shock absorber to fit. Do not modify the shock absorber.
3. FK18 rear sway bar extension bracket for LWB Models and FK24 for SWB Models are **mandatory** fitments with Nitrochargers to prevent damage to sway bar due to increased wheel droop.
4. FK22 support brackets must be installed to upper shock mounting brackets on late 1996 on models manufactured in Thailand.
5. Original struts and OME coils cannot be used together. No top mounting bushes and dirt shield supplied, re-use OE bushes and dirt shield.
6. Sway Bar/Brake Fitting Kit FK85 is **required** when fitting all OME rear shocks.
7. 60043 is 20mm longer and must only be installed to right hand side.
8. OMEB11 bush kit is required to convert lower 19mm bush to 16mm ID.
9. OMESD40 will only fit left hand drive models.
10. FK16 20mm bump stop spacer kit is a **mandatory** fitment.
11. No top mounting bushes supplied, re-use OE bushes. Where required, re-use OE Top Hat, Dirt Shield and Bump Stop.
12. When remaining stock is exhausted no further product will be available.
13. No top mounting bushes supplied, refer to vehicle specific application to select relevant upper strut bushes. OE bushes may be re-used if in good condition.
14. FK42 is a **mandatory** fitment to space sway bar link away from shock absorber.
15. OME front shock 60121 is not suitable as an OE replacement. When fitting our longer OME shock 60121 you must fit: FK71 brakeline kit to extend/drop the brakelines, FK72 sway bar kit to lower the front swaybar, FK70 radius arm drop bracket kit to 11 to 17 models, FK80 to 08 - 10 models as if not fitted you may over stretch the front brakelines.

Cont.

NITROCHARGER SPORT SELECTION

NOTES - (continued): *first part number has firmer valving.

16. Re-use rear OE top damper forged bracket, bushes, dirt shield, bumpstops and fasteners for the assembly of the rear shock.
17. No top mounting bushes supplied use OME3133 / OME3134 / OME3135, vehicle specific refer to vehicle selection page. OE bushes may be re-used if in good condition. OME struts can only be installed with OME coils.
18. 60130 and 60131 **cannot** be used as a shock only OE replacement on Colorado 7/Trailblazer Models. Can be used as an OE replacement for Isuzu MU-X.
19. No top mounting bushes supplied use OME3121. OE bushes may be re-used if in good condition. No dirt shield supplied, please re-use OE.
20. Shock absorber 60140¹² is suited for constant rear loading in excess of 800kgs.
21. 1975 and newer FJ40's may need to use N76 shocks in rear: Pre 1975 shock eye in the top of the axle housing use N89¹²/60032¹²/60064¹². Post 1975 lower shock eye is below leaf spring use N76 with OMEB11 Bush Kit.
22. FK29 Rear Driveshaft Spacer is a **mandatory** fitment.
23. Top mount bump stop and bushes not supplied, re-use OE items.
24. For trimming purposes only, maximum 1 packer per strut.
25. OME665 Lower Shock Mount Stone Guard is **mandatory** fitment to rear shocks to protect against severe stone pepping encountered on loose road surfaces.
26. FK22 Front Shock Absorber Upper Mount Support Bracket Kit is a **mandatory** fitment.
27. When fitting 60018¹²/60070¹² it is **mandatory** to fit longer coils 3062 - 3066 for springs to remain trapped with shocks fully extended, fit FK62 to prevent shock damage, fit FK63 for front driveshaft clearance and rear extended travel, fit FK64 which replaces OE upper shock mount when fitting rear shocks and remove any inner helper coils already fitted. **Caution:** Front driveshaft **MUST** be replaced / modified with Double Cardan Joints and checked for Uni bind with OME shocks installed at droop.
28. Caution: Due to altered gearbox mounts on models after 1998 any lift above OE ride height may cause front driveline vibration that can only be rectified by fitment of front Double Cardan Joints.
29. Caster Kit will increase caster angle by 2°. Check manufacturer's specifications to determine if Caster Kit is required. CALR1 suits 38mm wide control arms. CALR2 suits 44mm wide control arms.
30. Volkswagen Service Manual quotes that driveshaft bolts are a one use only. It is recommended to replace bolts. Replacement bolts Volkswagen Part Number N90991102 are to be sourced separately.
31. Suits 100mm coils
32. Vehicle specific, refer to vehicle selection page for full details and to review **important** notification regarding modifications for off road use only along with warranty implications. For JK Wrangler, Patrol GU Y61 & GQ Y60, LandCruiser 80 & 105 Series refer to Off Road Use Only vehicle specific pages.
33. For high articulation vehicles it is recommended to replace rear upper shock mount with FK64 and matching shock absorbers 60146¹² or 60147¹²
34. Fitment of FK92 and FK105 are **mandatory**.
35. Fitment of LCAJLFR Front Lower Control Arm is **required** to restore wheel alignment castor settings.
36. To ensure correct 90012 and 90013 strut fitment please refer to fitting instruction part number 3787896 Amarok Strut Fitting Guide.
37. For front fitment reuse OE Top hat and Mounting Bushes. For rear fitment UBolts, Rear Spring Bush Kits and Leaf Spring Bolt Fitting Kit are additional requirements. Extra Leaf, Trim Packer and Centre Bolt are optional. Refer to the vehicle selection page for full details.
38. Headlight Sensor Fitting Kit FK97 is required when fitting all OME extended travel rear shock absorbers.
39. Workshop tool FK102 **recommended** for rear shock fitment.
40. OME coils and struts can only be installed together due to different winding of the lower coil end to suit the OME coil seat. They are not compatible with the OE coil seat. Due to the nature of the KDSS. Models fitted with KDSS may experience a characteristic 10mm to 15mm lean to the front right hand side.
41. Spring selection based on Summit bar. If fitting a Sahara bar please select down one spring.
42. Use 60178¹² when adding an EL48XL Extra Leaf to an EL132R Leaf Spring or when carrying constant loads of 800kg and above.

Cont.

NITROCHARGER SPORT SELECTION

REPLACEMENT NITROCHARGER SPORT DIRT SHIELDS		PART NUMBER
Nitrocharger Dust Boot - Black		OME512422
Nitrocharger Dust Boot - Yellow		OME412422
Sports Dirt Shield - Strut		141-032-027
Sports Dust Boot - Black		141-032-028
Hard Sport Dirt Shield	170mm long	384006170
Hard Sport Dirt Shield	210mm long	384006210
Hard Sport Dirt Shield	250mm long	384006250
Hard Sport Dirt Shield	290mm long	384006290

Note: The last 3 numbers of the part number indicates the length of the dirt shield.

Remarks:

Refer to Specifications - Shock Absorbers Nitrocharger Sport section for open and closed lengths of equivalent standard Nitrocharger Sport models.

NITROCHARGER SPORT L SERIES						
Vehicle	Front	Open (mm)	Closed (mm)	Rear	Open (mm)	Closed (mm)
Jeep JK (Middle Front)	60066L ¹	693	404	60067L ¹	706	422
	60066M ¹	646	382	n/a	n/a	n/a
Jeep XJ	60052L	678	392	60053L	622	366
Jeep TJ	60047L ¹	678	392	60049L ¹	622	366
Patrol Y60, Y61	60013L ¹	555	322	60015L ¹	716	426
LandCruiser 80, 100	60070L ¹	667	381	60071L ¹	673	387
	60018L ¹	667	381	60020L ¹	673	387
Discovery I to 99	60037L ¹	593	349	60039L ¹	600	366
Discovery II to 04	60024L ¹	627	388	60025L ¹	627	388
Defender 90, 110, 130	60037L ¹	593	349	60039L ¹	600	366
Range Rover to 5/95 Non Airbag Models	60037L ¹	593	349	60039L ¹	600	366

Remarks:

Warranty Implications

The fitter selling these shocks **must** inform the customer there is **no warranty** due to the severe nature of competition racing. The fitter must also note on the customer's receipt "racing application no warranty applies". This will prevent any future misunderstanding.

1. When remaining stock is exhausted no further product will be available.

NITROCHARGERS & STEERING STABILISERS

SELECTION ADVICE

Where there is a choice of part numbers it is important the right selection is made with consideration given to type of spring rates and customer applications.

Firm Valving

The firm part number should be selected whenever heavy rate springs are fitted, as the valving has been specifically developed to control the higher spring rates. The firmer valving will provide better control when cornering, while also preventing axle bounce over rough roads.

If a softer valved selection is fitted with a heavy rate spring the vehicle's rebound handling will be reduced. This will be evident by axle bounce over rough roads, dipping under braking or cornering and wallowing over undulating roads.

Soft Valving

Valved specifically for light to medium rate springs. Most suitable for customers wanting a comfortable ride and regularly carry light to medium loads. Under full GVM load a slight amount of body roll during cornering and highway speed manoeuvring can occur.

A CAUTION FOR CUSTOMERS BUYING 4 REPLACEMENT SHOCK ABSORBERS

By the time a customer has decided to replace the old and well used original shock absorbers there is every chance that the original springs are also ready for replacement.

It should be explained to the customer that if their springs are sagged and tired that this would cause the shock absorbers to work a lot harder.

Therefore, the life expectancy of the shock absorbers will be considerably shortened and when loaded ride and handling qualities will also be reduced.

REMEMBER: A good set of shock absorbers will not overcome a bad set of springs.

YEAR	VEHICLE DESCRIPTION	OME NITROCHARGERS, STRUTS & CARTRIDGES		STEERING STABILISERS
		FRONT	REAR	
CHRYSLER JEEP				
2006 to 2010	Comander XK	*N219S/N188S	*N220/N190	
2008 to 2013	Cherokee/Liberty KK ALL Models	NS131 ^{16,18}	N132 ¹⁸	
2002 to 2007	Cherokee/Liberty KJ ALL Models (OME Springs)	*NS131 ^{16,18} /NS130 ^{16,18}	N132 ¹⁸	
2006 to 2010	Grand Cherokee WH & WK	*N219S/N188S ¹⁶	*N220/N190	
1998 to 2005	Grand Cherokee WJ & WG	See Sport Selection	N117 ¹⁸	
1993 to 1998	Grand Cherokee ZJ - 6 cylinder & V8 engines	*N39 ¹⁸	See Sport Selection	OMESD40 ¹⁰
1984 to 2001	Cherokee XJ - Petrol & Diesel	See Sport Selection	See Sport Selection	OMESD40 ¹⁰
to 1986	Cherokee Wagon & J10 Ute (Full Size)	N41 ^{1,18}	See Sport Selection	
1974 to 1986	Cherokee W10 & J20 Utes and Cab Chassis	N41 ^{1,18}	N43	
to 1986	CJ5, 6, 7, & 8	*N41 ¹⁸ /N81 ¹	-	
2006 to 2017	Wrangler JK - All Models	See Sport Selection	N198 ¹⁸	OMESD48
1997 to 2006	Wrangler TJ	*N66 ¹⁸ /N66C ¹⁸	See Sport Selection	OMESD40 ¹⁰
1986 to 1996	Wrangler YJ	N33	See Sport Selection	OMESD40 ¹⁰
DAIHATSU				
1992 to 1997	Feroza II F310	N18 ¹⁸	*N49/N96	
1988 to 1992	Feroza I F300	N18 ¹⁸	N43	
1993 on	Rocky F78 Wide Track	-	N33	OMESD31 ¹⁸ '86 on
84 to 8/1993	Rocky F70, F75, F80 & F85 Hard Top with Leaf Springs	OME027 ¹⁸	N43	OMESD31 ¹⁸ '86 on
1984 to 1993	Rocky F77 & 78 Tray Top with Leaf Springs	OME027 ¹⁸	*N48/N97	
All	Scat Hard Top	*N41 ¹⁸ /N81	*N48/N97	
FORD				
2006 to 2011	Ranger PJ All Models	N194 ^{6,18} /N187 ^{6,18}	See Sport Selection	
1985 to 2005	Courier/Ranger 1 Tonne not USA manufactured model	N51 ^{7,18}	See Sport Selection	
to 2001	Explorer 4x4 Only	N16	N17	
2005 to 2008	Ford F250 & F350	N195	N179	
1999 to 2004	Ford F250 & F350	N178	N179+N180 ⁹	
1987 to 1993	Raider Wagon	N51 ¹⁸	-	
All	Maverick Wagon & Hard Top	N23F ¹⁸	See Sport Selection	To 8/89 OMESD34 9/89 on OMESD36
	Maverick Ute & Cab Chassis	See Sport Selection	N25 ¹⁸	OMESD22

Cont.

NITROCHARGERS & STEERING STABILISERS

YEAR	VEHICLE DESCRIPTION	OME NITROCHARGERS, STRUTS & CARTRIDGES		STEERING STABILISERS
		FRONT	REAR	
FORD (continued)				
1981 to 1989	Bronco (Single I Beam Front End)	-	See Sport Selection	
	Bronco (Dual I Beam Front End)	-	See Sport Selection	
	F100 4x4 & 4x2 (Single I Beam)	-	See Sport Selection	
HOLDEN/ISUZU/CHEVY				
2008 to 2011	GM/Isuzu Pick up - Colorado RC/DMAX Diesel Models	See Sport Selection	N89 ¹⁸	
	GM/Isuzu Pick up - Colorado V6/DMAX Petrol	See Sport Selection	N89 ¹⁸	
2003 to 2011	Rodeo Pick Up - RA Models	See Sport Selection	N89 ¹⁸	
2003 to 2008	Rodeo Pick Up - RA & RA7 Models	See Sport Selection	N89 ¹⁸	
7/81 to 2003	Rodeo/Isuzu Pick Up KB4, KBD4 & TFS	See Sport Selection	N89 ¹⁸	
1992 to 2004	Jackaroo/Trooper & Monterey (Isuzu Wagon)	See Sport Selection	See Sport Selection	
11/86 to 3/92	Jackaroo/Trooper	See Sport Selection	N89 ¹⁸	
82 to 10/1986	Jackaroo/Trooper	See Sport Selection	N89 ¹⁸	
99 to 6/2003	Frontera Wagon	See Sport Selection	N102 ¹⁸	
1995 to 1998	Frontera 2 & 4 Door UT	See Sport Selection	See Sport Selection	
1985 to 1987	Drover QB (OE Springs)	OME025	-	OMESD30
	Drover QB (OME Springs Fitted)	-	OME013	OMESD30
KIA				
2006 to 2009	Sorento All BL Models	N147S ^{16,18} + N148S ^{16,18}	N205	
03 to Late 06	Sorento All Models	N147S ^{16,18} + N148S ^{16,18}	N149	
LAND ROVER				
1999 to 2004	Discovery Series II (Not Suitable for Air Bag Models)	*N107 ¹⁸	N108 ¹⁸	OMESD02
1991 to 1999	Discovery Series I	N45F ¹⁸	See Sport Selection	OMESD11
1994 to 2001	Range Rover MK II P38A Models	N176 ¹⁴	N177 ¹⁴	
to 5/1995	Range Rover (Not Suitable for Air Bag Models)	N45F ¹⁸	See Sport Selection	OMESD11
1984 on	Defender / County 110 & 130	N45F ¹⁸	See Sport Selection	OMESD32
	Defender / County 90	N45F ¹⁸	See Sport Selection	OMESD32
to 1984	Land Rover Series I, II & III (80" & 109")	N78	N69	OMESD11
	Land Rover Series II & III (88" SWB)	N78	N90 ¹⁸	OMESD11
MAHINDRA				
1990 to 1993	Bushranger & Stockman CJ340	*N41 ¹⁸ /N81 ¹	*N41 ¹⁸ /N81 ¹	
MAZDA				
2006 to 2011	Mazda BT50 All Models	*N194 ^{6,18} /N187 ^{6,18}	See Sport Selection	
1987 to 2006	B2600 Pick Up All Models	N51 ^{6,18}	See Sport Selection	
MITSUBISHI				
2015 on	Pajero Sport All Diesel Models	See Sport Selection	See Sport Selection	
4/00 to 2006	Pajero/Montero SWB NS, NM, NP & NT (3.2 Diesel)	See Sport Selection	See Sport Selection	
	Pajero/Montero SWB NS, NM, NP,NT, Hard Top (V6)	See Sport Selection	See Sport Selection	
91 to 3/2000	Pajero/Montero (Rear Coil) NH, NJ, NK & NL	N18 ¹⁸	See Sport Selection	
	Pajero/Montero (Rear Leaf) NH, NJ, NK & NL	N18 ¹⁸	See Sport Selection	
89 to 5/1991	Pajero/Montero (Rear Coil) NF & NG	See Sport Selection	See Sport Selection	
to 4/1991	Pajero/Montero (Rear Leaf) NA, NB, NC, ND, NE, NF & NG	See Sport Selection	See Sport Selection	
2009 to 2015	Challenger/Montero Sport KH	See Sport Selection	See Sport Selection	
2000 to 2008	Challenger/Montero Sport (Rear Coil Springs)	See Sport Selection	See Sport Selection	
1998 to 2000	Challenger/Montero Sport (Rear Leaf Springs)	See Sport Selection	See Sport Selection	
7/06 to 2015	Triton/L200 ML & MN All Models	See Sport Selection	N59 ¹⁸	
10/96 to 6/06	Triton/L200 MK All Models	N18 ¹⁸	N30E ¹⁸	
91 to 8/1996	Triton/L200 V6 (OE Springs)	See Sport Selection	N30E ¹⁸	
	Triton/L200 (V6) MH & MJ	See Sport Selection	See Sport Selection	
86 to 8/1996	Triton/L200 (4 Cylinder) ME, MF, MG, MH & MJ	See Sport Selection	See Sport Selection	

Cont.

NITROCHARGERS & STEERING STABILISERS

YEAR	VEHICLE DESCRIPTION	OME NITROCHARGERS, STRUTS & CARTRIDGES		STEERING STABILISERS
		FRONT	REAR	
MITSUBISHI (continued)				
to 1986	L200 MA, MB, MC & MD	See Sport Selection	See Sport Selection	
to 9/1986	L300 Vans SA, SB, SC & SD	See Sport Selection	N89 ¹⁸	
NISSAN				
2/2000 on	Patrol Y61 (GU) SWB & Wagon	N19 ¹⁸	See Sport Selection	OMESD01
1997 on	Patrol Y61 (GU) Cab Chassis (Coil Front/Leaf Rear)	N19 ¹⁸	N25 ¹⁸	OMESD11
	Patrol Y61 (GU) Cab Chassis (All Coil Springs)	N19 ¹⁸	See Sport Selection	OMESD11
97 to 1/2000	Patrol Y61 (GU) Wagon & SWB	N19 ¹⁸	See Sport Selection	OMESD11
9/1989 on	Patrol Y60 (GQ) Wagon & SWB	N23F ¹⁸	N22F ¹⁸	OMESD36
	Patrol Y60 (GQ) Cab Chassis (Coil Springs)	N23F ¹⁸	N22F ¹⁸	OMESD36
to 8/1989	Patrol Y60 (GQ) Wagon & SWB	N23F ¹⁸	N22F ¹⁸	OMESD34
88 to 7/1997	Patrol Y60 (GQ) Ute & Cab Chassis (Leaf Springs)	See Sport Selection	N25 ¹⁸	OMESD22
All	Patrol MQ 260 LWB Spanish Built 2.8td Models	N19 ¹⁸	N89 ¹⁸	
8/83 to 1988	Patrol MQ Wagon, SWB, Ute & Cab Chassis	N49	N48/N97	OMESD22
80 to 7/1983	Patrol MQ Wagon, SWB, Ute & Cab Chassis	*N47/N96	N48/N97	OMESD22
1967 to 1979	Patrol 60 & G60 Series	N49	N49	OMESD22
2005 to 2014	Pathfinder R51	See Sport Selection	See Sport Selection	
2/99 to 2005	Pathfinder R50 V6 Model	N145S+N146S ^{16,18,21}	N104	
96 to 1/1999	Pathfinder R50 V6 Model	N145S+N146S ^{16,18,21}	N61	
86 to 8/1995	Pathfinder/Terrano WD21	See Sport Selection	N89 ¹⁸	OMESD35 ¹⁸
2005 on	Navara D40	See Sport Selection	N185 ¹⁸	
10/2002 on	Navara D22	See Sport Selection	N59 ¹⁸	
2008 to 2014	NP300 All Models	See Sport Selection	N59 ¹⁸	
1/1986 on	Navara D21 & D22 Pick Up 4x2	N18 ^{4,18}	*N41 ¹⁸ /N81	
1/86 to 8/02	Navara D21 & D22 Pick Up	See Sport Selection	N59 ¹⁸	OMESD35 ^{12,18}
1996 to 2005	Terrano II 4x4 (European Models) (OE Springs)	See Sport Selection	See Sport Selection	
2005 on	Xterra	See Sport Selection	N185 ^{18,20}	
1980 to 1985	720 Ute & Cab Chassis	N18 ¹⁸	N89 ¹⁸	
SSANGYONG				
to 2005	Musso, Sport Utility & Korando Models	See Sport Selection	N118	
SUZUKI				
2009 on	Equator (US Market Only)	See Sport Selection	N185 ¹⁸	
2001 to 2005	XL7 Wagon V6	N103S ¹⁷	N105	
8/05 to 2015	Grand Vitara Wagon Models	N217S + N218S	OME036	
1995 to 2005	Grand Vitara petrol 4 & 6 Cylinder & diesel engines	N103S	N105	
7/88 to 2005	Vitara TA01, TD01 & Wagon	N103S	N105	
	Vitara TA012 TD01 SWB	N103S ²²	N32 ²³	
to 2017	Jimny SN413 (OE Springs)	OME028	OME030 ^{17,18}	
to 2017	Jimny SN413 (OME Springs)	OME028	OME029	
to 2004	Santana Samurai All Models	OME034	OME035	OMESD30 ¹³
1982 to 1995	Sierra SJ410 & SJ413 Ute MG410/WT1000cc (OME Springs)	-	OME013	OMESD30 ¹³
1988 to 1996	Sierra SJ70, SJ71, SJ413, MG410/WT1300cc (OME Springs)	OME025	OME013	OMESD30 ¹³
78 to 12/1981	LJ80 & LJ80V SWB (OE Springs)	OME025	-	OMESD30 ^{13,14}
	LJ80 & LJ80V SWB (OME Springs)	-	N43	OMESD30 ¹³
	LJ80 Ute (OME Springs)	-	OME013	OMESD30 ¹³
74 to 12/1981	540, LJ10, LJ20 & LJ50 (OME Springs)	-	OME013	OMESD30 ¹³
TOYOTA				
07 to 07/2021	LandCruiser 200 Series V8 Not AHC	N208S ^{8,18}	N209 ¹⁸	
3/1998 on	LandCruiser 100 Series (IFS) Not AHC	*N199 ¹⁸ /N133 ¹⁸	N101 ^{1,18}	
	LandCruiser 100 & 105 Series (Front Live Axle)	N73 ¹⁸	See Sport Selection	OMESD24
4/90 to 1998	LandCruiser 80 Series	N73 ¹⁸	See Sport Selection	OMESD24
4/03 to 2009	Prado 120 Series (Except TEMS/Grande Models)	*N201S ^{18,19} / N139S ^{13,18}	N202 ^{2,18} /N141 ^{2,18}	

Cont.

NITROCHARGERS & STEERING STABILISERS

YEAR	VEHICLE DESCRIPTION	OME NITROCHARGERS, STRUTS & CARTRIDGES		STEERING STABILISERS
		FRONT	REAR	
TOYOTA (continued)				
7/96 to 10/02	Prado 95 & KZJ90 Series	N91SC ¹⁸	N86 ^{2,18}	
2007 on	LandCruiser 78 & 79 Series V8 Diesel Model	N106 ¹⁸	See Sport Selection	OMESD47
	LandCruiser 78 & 79 Series 6 Cyl. Petrol & Diesel Models	See Sport Selection	See Sport Selection	OMESD47
1999 to 2006	LandCruiser 78 & 79 Series - 6 Cylinder Models	N106 ¹⁸	See Sport Selection	OMESD24
2007 on	LandCruiser 76 Series Wagon - V8	N106 ¹⁸	See Sport Selection	OMESD47
1985 to 1999	LandCruiser 75 Series	*N50/N92 ¹⁸	See Sport Selection	OMESD24
All	LandCruiser II LJ/RJ70, LJ/KZJ71 & LJ/KZJ78 Models	N77 ¹⁸	N79 ¹⁸	OMESD24
1984 to 1990	LandCruiser Bundera, SWB, LJ70 & RJ70 Series	N114 ¹⁸	N113 ¹⁸ RHS	
All	LandCruiser 70 Series Dual Cab	N181 ^{15,18}	See Sport Selection	OMESD24
1985 on	LandCruiser 70,73 & 74 Series SWB & MWB	*N50/N92 ¹⁸	*N85 ¹⁸ /N94 ¹⁸	OMESD24
to 2007	LandCruiser HZJ71 & HJZ74 Series	N106 ¹⁸	See Sport Selection	OMESD24
86 to 3/1990	LandCruiser 60,61 & 62 Series (Rear Lower Pin 19mm)	*N50/N92 ¹⁸	*N90 ¹⁸ /N85 ¹⁸ /N94 ¹⁸	OMESD24
1980 to 1986	LandCruiser 60 Series (Rear Lower Pin 16mm)	*N50/N92 ¹⁸	N89 ¹⁸	OMESD24
	LandCruiser 60 Series (OE Springs)	N50	See Sport Selection	OMESD24
1986 to 3/90	LandCruiser 60 Series (OE Springs)	N50	N90 ¹⁸ /N85 ¹⁸	OMESD24
to 11/1980	LandCruiser FJ55	N43	See Sport Selection	
to 12/1984	LandCruiser 45 & 47 Series All LWB Models	*N41 ¹⁸ /N81	N89 ^{3,18}	OMESD23
	LandCruiser BJ, FJ & HJ 40 & 42 Series SWB	*N41 ¹⁸ /N81	N89 ^{3,18}	OMESD23
	LandCruiser BJ, FJ & HJ 40 & 42 Series (OE Springs)	N41 ¹⁸	See Sport Selection	OMESD23
2004 to 2015	Fortuner	N166S ^{18,19}	See Sport Selection	
2006 to 2010	FJ Cruiser	See Sport Selection	N141 ^{2,18}	
2005 to 2015	HiLux Vigo KUN26R, GGN25R	N166S ^{18,19}	See Sport Selection	
9/97 to 2004	HiLux Tiger LN172, LN167, KZN 165, RZN174 & RZN169 (IFS)	See Sport Selection	N75 ¹⁸	OMESD33
9/83 to 8/97	HiLux LN65, YN65, LN106 & RN105 (All Leaf Suspension)	See Sport Selection	*N85 ¹⁸ /N94 ¹⁸	OMESD21
to 8/1983	HiLux LN46 & RN46 (All Leaf) (Rear Lower Pin 16mm)	See Sport Selection	N89 ¹⁸	OMESD21
	HiLux LN46 & RN46 (AS ABOVE) With OE Springs	See Sport Selection	N89 ¹⁸	OMESD21
9/83 to 8/97	HiLux LN65, YN65, LN106 & RN105 (OE Springs)	See Sport Selection	*N90 ¹⁸ /N85 ¹⁸	OMESD21
88 to 8/1997	HiLux/4 Runner LN107, RN105, RN110 & LN111 (IFS)	See Sport Selection	*N85 ¹⁸ /N94 ¹⁸	OMESD33
	HiLux/4 Runner (AS ABOVE) With OE Springs	See Sport Selection	*N90 ¹⁸ /N85 ¹⁸	OMESD33
2003 to 2012	4 Runner (USA)	See Sport Selection	N141 ¹⁸	
1996 to 2002	4 Runner/Surf Front & Rear Coil Springs (USA)	N91SC ¹⁸	N86 ¹⁸	
1990 to 1996	4 Runner (IFS) Front Torsion Bar/Rear Coil Springs	See Sport Selection	N72F ¹⁸	OMESD33
1986 to 1990	4 Runner (IFS) Rear Leaf Springs (OE Springs)	See Sport Selection	N85 ¹⁸ /N94 ¹⁸	OMESD33
	4 Runner (IFS) Rear Leaf Springs	See Sport Selection	*N85 ¹⁸ /N94 ¹⁸	OMESD33
1984 to 1986	4 Runner (Front Live Axle) (OE Springs)	See Sport Selection	N90 ¹⁸ /N85 ¹⁸	OMESD21
	4 Runner (Front Live Axle)	See Sport Selection	N85 ¹⁸ /N94 ¹⁸	OMESD21
1982 to 1983	Blizzard	*N41 ¹⁸ /N81	N48	
1997 to 2003	Kijang (4th Gen.)	N128 ¹⁸	-	
2005 to 2015	Tacoma V6	See Sport Selection	N182 ¹⁸	
to 2004	Tacoma V6 & 4 Cylinder Models	N91SC ¹⁸	N85 ¹⁸	
2007 on	Tundra	N192S ¹⁶	N193	
VOLKSWAGEN				
1985 to 1990	Syncro 4x4	N38S	N37	

Remarks:

Refer to Specifications - Shock Absorbers Nitrocharger section for open and closed lengths of equivalent standard Nitrocharger models.

NOTES: *first part number has firmer valving.

1. 1983 and on wide track CJ Jeeps require bush kit OMEB27 for the front lower mount and all Cherokee wagons and Mahindra lower front and rear mounts.

Cont.

NITROCHARGERS & STEERING STABILISERS

NOTES - (continued): *first part number has firmer valving.

2. Shock lower body stone guards are recommended fitment to rear shocks to protect against severe stone pepping encountered on loose road surfaces. OME661 (suits Sorento BL To 09, FJ Criser 06 On, 4 Runner 10 On, LandCruiser 76 LWB, 200 Series, Prado 150 09 on coil sprung not Kakadu, 120 Series 10/02 to 09 not TEMS & Prado 90 Series to 10/2002 LWB). OME662 (suits LandCruiser 105 & 80 Series with 34mm diameter Control Arm, 100 Series IFS not AHC with 40mm diameter Control Arm). OME660 (all other models).
3. 1975 and newer FJ40's may need to use N76 shocks in rear: Pre 1975 shock eye in the top of the axle housing use N89¹⁸/60032¹⁸/60064¹⁸. Post 1975 lower shock eye is below leaf spring use N76 with OMEB11 Bush Kit.
4. It may be necessary to slightly increase the clearance in the front wishbone to allow the shock absorber to fit. Do not modify the shock absorber.
5. FK18 rear sway bar extension bracket for LWB models and FK24 for SWB models are **mandatory** fitment with Nitrochargers to prevent damage to sway bar due to increased wheel droop.
6. FK22 Front Shock Absorber Upper Mount Support Bracket Kit is a mandatory fitment.
7. FK22 support brackets must be installed to upper shock mounting brackets on late 1996 on models manufactured in Thailand.
8. N208S¹⁸ can only be installed with OME Coil Springs. No top mounting bushes supplied, re-use OE bushes.
9. N179 suits models with single rear shock set up. Models with twin rear shocks require N179 fitment rear of axle, N180 front of axle, also fitment of OME660 stone shields are recommended on the N180.
10. OMESD40 will only fit left hand drive models.
11. To obtain maximum ride quality improvement it is recommended that an OME replacement stabiliser bar (OMESTAB1) be fitted.
12. OMESD35¹⁸ will suit D21 models only.
13. Only suitable for models equipped with original steering damper.
14. Shocks are the same length as OE.
15. OME030¹⁸ is shorter than OME029 and must be used with OE coils to ensure coils remain entrapped.
16. No top mounting bushes supplied, re-use OE bushes.
17. FK28¹⁸ Bump Stop Spacer Kit is a mandatory fitment with N103S Struts.
18. When remaining stock is exhausted no further product will be available.
19. No top mounting bushes supplied, refer to vehicle specific application to select relevant upper strut bushes. OE bushes may be re-used if in good condition.
20. FK42 is a **mandatory** fitment to space sway bar link away from shock absorber.
21. Vehicles with ABS will require ABS Bracket Kit SMP638.
22. Front strut has 40mm longer travel than original equipment.
23. Rear shock has 50mm longer travel than original equipment.

**Note: Replacement dust boot part numbers Nitrocharger: OME412422 - Small
Replacement dust boot part numbers Nitrocharger: OME512422 - Large**

COMPACT AWD - OME SPRING & SHOCK ABSORBER

YEAR	VEHICLE DESCRIPTION	LIFT F/R (mm)	FRONT	REAR
DAIHATSU				
97 to 2006	Terios J100 J102	20/20	2531 ¹	No longer Available
FORD				
To 06/2006	Escape BA ZA AB	30/30	2904	No longer Available
04 to 10/2007	Territory SX SY AWD (4WD)	20/30	2533 ¹	2534 ¹
GM / OPEL				
2006 on	Captiva, Antara - V6 (3.2) & Diesel	20/30	2529 ¹	2530 ¹
HONDA				
01/2007 on	CRV	20/20	No longer Available	2536
12/01 to 01/07	CRV MY 2002 MY 2005	-/20	CANNOT LIFT	2538
10/97 to 11/01	CRV RD	30/30	2797	2798
HYUNDAI				
05/06 to 05/09	Santa Fe CM V6 (2.7) & Diesel	20/30	2527 ¹	2528 ¹
2000 to 2005	Santa Fe	10/20	2907 ¹	2908 ¹
KIA				
2005 to 2009	Sportage V6 & Diesel KM Models	20/20	No longer Available	2526 ¹
1997 to 2003	Sportage JA MY02 MY03 - V6	20/30	No longer Available	2524 ¹
LAND ROVER				
11/00 to 1/04	Freelander V6 & 2Ltr Diesel DOHC - Wagon	10/20	No longer Available	No longer Available
To 10/2000	Freelander 4 Cylinder Petrol Wagon	10/20	2504 ¹	2505 ¹
	OME Cartridge to Suit OME Springs		No longer Available	No longer Available
	Freelander V6 & 2Ltr Diesel DOHC	10/20	2500 ¹	No longer Available
	OME Cartridge to Suit OME Springs		No longer Available	No longer Available
LEXUS				
2003 on	RX-330 4WD MCU38R MY05 - V6	20/30	2509 ¹	2510 ¹
MAZDA				
To 06/2006	Tribute YU MY03 MY04	30/30	2904	2905
NISSAN				
2007 to 2011	X-Trail Petrol	25/25	2511 ¹	2512 ¹
	X-Trail Diesel	25/25	No longer Available	2512 ¹
01 to 10/2006	X-Trail Petrol	20/20	2506 ¹	No longer Available
	X-Trail Diesel	30/30	No longer Available	
01 to 10/2006	OME Strut to Suit OME Springs		N213S+N214S	N215S+N216S
SUBARU				
7/02 to 2005	Forester MY03 MY04 MY05	20/20	No longer Available	2520 ¹
9/03 to 2006	Outback 4th Gen MY04 MY05 MY06 4Cyl	20/20	2516 ¹	2518 ¹
	Outback 4th Gen MY04 MY05 MY06 6Cyl	20/20	2517 ¹	2518 ¹
TOYOTA				
03 to 04/2007	Kluger / Highlander MCU20R - V6	20/20	2509 ¹	2510 ¹
01/2006 on	Rav 4 LWB ACA33R - 4 Cylinder	30/30	No longer Available	No longer Available
	Rav 4 SWB & LWB ACA20R ACA21R - Diesel	40/40	No longer Available	2795
07/00 to 08/05	Rav 4 SWB & LWB ACA20R ACA21R - Petrol	40/40	2793 ²	2795
	OME Struts / Gas Shocks to Suit OME Springs		No longer Available	OME031
To 2000	Rav 4 LWB SXA11R MY98 MY99 - Petrol	25/25	2793 ²	2794
	OME Struts / Gas Shocks to Suit OME Springs		No longer Available	OME031
	Rav 4 SWB SXA11R MY98 MY99 - Petrol	25/25	2793 ²	No longer Available
	OME Struts / Gas Shocks to Suit OME Springs		No longer Available	OME031

NOTES:

1. When remaining stock is exhausted no further product will be available.
2. Suits OE strut.

GVM UPGRADE - FORD

RANGER PY 2022 ON

AUSTRALIA ONLY

OE GVM		3190kg to 3350kg	FOR PRE REGISTERED VEHICLES ONLY		
Upgraded GVM		3650kg	SEATING CAPACITY: 2, 4, 5		
RVSA Approval Number		VTA-060700	*SPECIAL REQUIREMENTS*		
Compliance Kit Number		RAN3650	Minimum of 600kg permanently carried load at all times.		
Axle Loads		1450kg - 1490kg	NOTE: Warning Labels part numbers 215738/215739/215776, Tyre placard part number 215973, are supplied with compliance kits.		
	Front OE		Front Upgraded	1640kg	
	Rear OE	1959kg	Rear Upgraded	2100kg	
VEHICLE VARIANTS 4X4 & 4X2 HI-RIDER					
DESCRIPTION	BODY STYLE	ENGINE	TRANSMISSION	TYRE DESIGNATION	RIM SIZE
Dual Cab	Utility	2.0 Diesel	Automatic	255/70R16	16x7J
		3.0 Diesel		255/70R17	17X7.5J
				255/65R18	18X7.5J
Dual Cab	Cab Chassis	2.0 Diesel	Automatic	255/70R16	16x7J
		3.0 Diesel		255/70R17	17X7.5J
				255/65R18	18X7.5J
Super Cab	Utility	2.0 Diesel	Automatic	255/70R16	16x7J
				255/70R17	17X7.5J
				255/65R18	18X7.5J
Super Cab	Cab Chassis	2.0 Diesel	Automatic	255/70R16	16x7J
				255/70R17	17X7.5J
				255/65R18	18X7.5J
Single Cab	Cab Chassis	2.0 Diesel	Automatic	255/70R16	16x7J
				255/70R17	17X7.5J
				255/65R18	18X7.5J

SUSPENSION SELECTION

CAT6 INDICATORS ARE REQUIRED		
DESCRIPTION	PART NUMBER	QTY
CAT 6 Indicators	OMELT0002	2
Wiring Harness	6821446	1
Fitment time: 1 hour		

FRONT SELECTION	
DESCRIPTION	PART NUMBER
NITROCHARGER SPORT	
NO ACCESSORIES	3207
BAR ONLY	3208
BAR & WINCH	3209
BAR/ WINCH & ACCESSORIES	3210
NO ACCESSORIES - 20mm lift	3211
NITROCHARGER SPORT	*90053 / 90052
NITROCHARGER PLUS / MT64	
SPRING 40mm	4024
SPRING 20mm	4028
STRUT - NITROCHARGER PLUS	*93053 / 93052
STRUT - MT64	MT64902001
STRUT - MT64 HEAVY VALVED	*MT64902002
BP-51	
BP-51 COIL OVER RH	BP5190015R
BP-51 COIL OVER LH	BP5190015L
BP-51 FRONT FIT KIT	VM80010053
FIT KITS & HARDWARE	
UPPER CONTROL ARM (optional)	UCA0009
TRIM PACKER (if required)	FK112

REAR SELECTION	
DESCRIPTION	PART NUMBER
LEAF SPRINGS	
CONSTANT 600kg	EL132R
EXTRA LEAF (if required)	EL48XL + ELSK15
NITROCHARGER SHOCKS	
NITROCHARGER SPORT	*60178 / 60173
NITROCHARGER PLUS	*63178 / 63173
MT64	
SHOCK	MT64602003L/R
SHOCK - HEAVY VALVED	MT64602004L/R
BP-51	
BP-51 SHOCK RH	BP5160055R
BP-51 SHOCK LH	BP5160055L
BP-51 REAR FIT KIT	VM80010052
FIT KITS & HARDWARE	
U BOLTS	OMEU82
	OMEU83
SPRING BUSH KIT	OMESB117
GREASEABLE SHACKLE BUSH KIT (optional)	OMESB118
GREASABLE SHACKLE KIT (optional)	OMEGS20
GREASABLE PIN KIT (optional)	OMEGP10
DRIVELINE SPACER KIT (if required)	FK113
HEADLIGHT SENSOR BRACKET (if required)	FK114
BUMP STOP ADAPTER KIT (if required)	FK115

NOTE: There is a choice of front and rear springs depending on the set up of the particular vehicle. Please read comments relating to fitment of components. For all information refer to the vehicle specific selection page.

GVM UPGRADE - FORD

RANGER PY 2022 ON

AUSTRALIA ONLY

OE GVM		3190kg to 3350kg	FOR PRE REGISTERED VEHICLES ONLY		
Upgraded GVM		3500kg	SEATING CAPACITY: 2, 4, 5		
RVSA Approval Number		VTA-060701	*SPECIAL REQUIREMENTS* Minimum of 300kg permanently carried load at all times.		
Compliance Kit Number		RAN3500	NOTE: Axle Upgrade label part number 215781, Tyre Placard part number 215972 are supplied with compliance kits.		
Axle Loads	Front OE	1450kg - 1490kg	Front Upgraded	1640kg	
	Rear OE	1959kg	Rear Upgraded	2020kg	
VEHICLE VARIANTS 4X4 & 4X2 HI-RIDER					
DESCRIPTION	BODY STYLE	ENGINE	TRANSMISSION	TYRE DESIGNATION	RIM SIZE
Dual Cab	Utility	2.0 Diesel	Automatic	255/70R16	16x7J
		3.0 Diesel	Manual	255/70R17 255/65R18	17X7.5J 18X7.5J
Dual Cab	Cab Chassis	2.0 Diesel	Automatic	255/70R16	16x7J
		3.0 Diesel	Manual	255/70R17 255/65R18	17X7.5J 18X7.5J
Super Cab	Utility	2.0 Diesel	Automatic	255/70R16	16x7J
			Manual	255/70R17 255/65R18	17X7.5J 18X7.5J
Super Cab	Cab Chassis	2.0 Diesel	Automatic	255/70R16	16x7J
			Manual	255/70R17 255/65R18	17X7.5J 18X7.5J
Single Cab	Cab Chassis	2.0 Diesel	Automatic	255/70R16	16x7J
			Manual	255/70R17 255/65R18	17X7.5J 18X7.5J

SUSPENSION SELECTION

FRONT SELECTION	
DESCRIPTION	PART NUMBER
NITROCHARGER SPORT	
NO ACCESSORIES	3207
BAR ONLY	3208
BAR & WINCH	3209
BAR/ WINCH & ACCESSORIES	3210
NO ACCESSORIES - 20mm lift	3211
NITROCHARGER SPORT	*90053 / 90052
NITROCHARGER PLUS / MT64	
SPRING 40mm	4024
SPRING 20mm	4028
STRUT - NITROCHARGER PLUS	*93053 / 93052
STRUT - MT64	MT64902001
STRUT - MT64 HEAVY VALVED	*MT64902002
BP-51	
BP-51 COIL OVER RH	BP5190015R
BP-51 COIL OVER LH	BP5190015L
BP-51 FRONT FIT KIT	VM80010053
FIT KITS & HARDWARE	
UPPER CONTROL ARM (optional)	UCA0009
TRIM PACKER (if required)	FK112

REAR SELECTION		
DESCRIPTION	PART NUMBER	
LEAF SPRINGS		
CONSTANT 300kg	EL131R	
CONSTANT 600kg	EL132R	
EXTRA LEAF (if required)	EL48XL+ELSK15	
NITROCHARGER SHOCKS	SPORT	PLUS
	60172	63172
	60173	63173
	60178	63178
MT64		
SHOCK	MT64602003L/R	
SHOCK - HEAVY VALVED	MT64602004L/R	
BP-51		
BP-51 SHOCK RH	BP5160055R	
BP-51 SHOCK LH	BP5160055L	
BP-51 REAR FIT KIT	VM80010052	
FIT KITS & HARDWARE		
U BOLTS	OMEU82	
	OMEU83	
SPRING BUSH KIT	OMESB117	
GREASEABLE SHACKLE BUSH KIT (optional)	OMESB118	
GREASABLE SHACKLE KIT (optional)	OMEGS20	
GREASABLE PIN KIT (optional)	OMEGP10	
DRIVELINE SPACER KIT (if required)	FK113	
HEADLIGHT SENSOR BRACKET (if required)	FK114	
BUMP STOP ADAPTER KIT (if required)	FK115	

NOTE: There is a choice of front and rear springs depending on the set up of the particular vehicle. Please read comments relating to fitment of components. For all information refer to the vehicle specific selection page.

GVM UPGRADE - ISUZU

DMAX 2021 ON 4X4 AND 4X2 HI-RIDER

AUSTRALIA ONLY

OE GVM		3100kg	FOR PRE REGISTERED VEHICLES ONLY		
Upgraded GVM		3500kg	SEATING CAPACITY: 2, 5		
RVSA Approval Number		VTA-060161	*SPECIAL REQUIREMENTS*		
Compliance Kit Number		DM3500	Minimum of 600kg permanently carried load at all times.		
Axle Loads		1450kg	NOTE: Warning Labels, part numbers 215758/38/39, supplied with compliance kits. For specific placement locations refer to PIB Release No.1587		
	Front OE	1450kg	Front Upgraded	1595kg	
	Rear OE	1910kg	Rear Upgraded	2100kg	
VEHICLE VARIANTS - 4X4 AND 4X2 HI-RIDER					
DESCRIPTION	BODY STYLE	ENGINE	TRANSMISSION	TYRE DESIGNATION	RIM SIZE
Crew Cab	Utility	3.0 Diesel	Manual Automatic	255/65/R17 265/60/R18	17x7J 18x7.5J
Crew Cab	Cab Chassis	3.0 Diesel	Manual Automatic	255/65/R17	17x7J
Space Cab	Utility	3.0 Diesel	Automatic	255/65/R17 265/60/R18	17x7J 18x7.5J
Space Cab	Cab Chassis	3.0 Diesel	Manual Automatic	255/65/R17	17x7J
Single Cab	Cab Chassis	3.0 Diesel	Manual Automatic	255/65/R17	17x7J

SUSPENSION SELECTION

FRONT SELECTION	
DESCRIPTION	PART NUMBER
NITROCHARGER SPORT	
NO ACCESSORIES	2883
BAR ONLY	3114
BAR & WINCH	2884
BAR/ WINCH & ACC	2885
STRUTS	*90046 / 90045
NITROCHARGER PLUS	
STRUTS	*93046 / 93045
SPRINGS	4001
BP-51	
BP-51 COIL OVER RH	BP5190014R
BP-51 COIL OVER LH	BP5190014L
BP-51 FRONT FIT KIT	VM80010044
FIT KITS & HARDWARE	
UPPER CONTROL ARM (optional)	UCA0007
TRIM PACKER (if required)	OME95PF5

REAR SELECTION	
DESCRIPTION	PART NUMBER
LEAF SPRINGS	
CONSTANT 600kg	EL125R
EXTRA LEAF (if required)	EL39XL
SHOCKS	
NITROCHARGER SPORT	60168
NITROCHARGER PLUS	63168
BP-51	
BP-51 SHOCK REAR	BP5160050
BP-51 REAR FIT KIT	VM80010045
FIT KITS & HARDWARE	
U BOLTS	OMEU53A OMEU53B
SPRING BUSH KIT	OMESB120
GREASABLE BUSH KIT (optional)	OMESB119
GREASABLE SHACKLE KIT (optional)	OMEGS26
GREASABLE PIN KIT (optional)	OMEGP9
HANDBRAKE CABLE FIT KIT	FK66

NOTE: There is a choice of front and rear springs depending on the set up of the particular vehicle. Please read comments relating to fitment of components. For all information refer to the vehicle specific selection page.

GVM UPGRADE - ISUZU

DMAX 2021 ON 4X4 AND 4X2 HI-RIDER

AUSTRALIA ONLY

OE GVM		3100kg	FOR PRE REGISTERED VEHICLES ONLY		
Upgraded GVM		3360kg			
RVSA Approval Number		VTA-060161			
Compliance Kit Number		DM3360			
SEATING CAPACITY: 2, 5					
Axle Loads	Front OE	1450kg	Front Upgraded	1450kg	
	Rear OE	1910kg	Rear Upgraded	1910kg	
VEHICLE VARIANTS - 4X4 AND 4X2 HI-RIDER					
DESCRIPTION	BODY STYLE	ENGINE	TRANSMISSION	TYRE DESIGNATION	RIM SIZE
Crew Cab	Utility	3.0 Diesel	Manual Automatic	255/65/R17 265/60/R18	17x7J 18x7.5J
Crew Cab	Cab Chassis	3.0 Diesel	Manual Automatic	255/65/R17	17x7J
Space Cab	Utility	3.0 Diesel	Automatic	255/65/R17 265/60/R18	17x7J 18x7.5J
Space Cab	Cab Chassis	3.0 Diesel	Manual Automatic	255/65/R17	17x7J
Single Cab	Cab Chassis	3.0 Diesel	Manual Automatic	255/65/R17	17x7J

SUSPENSION SELECTION

FRONT SELECTION	
DESCRIPTION	PART NUMBER
NITROCHARGER SPORT	
NO ACCESSORIES	2883
BAR ONLY	3114
BAR & WINCH	2884
BAR/ WINCH & ACC	2885
STRUTS	*90046 / 90045
NITROCHARGER PLUS	
SPRING	4001
STRUTS	*93046 / 93045
BP-51	
BP-51 COIL OVER RH	BP5190014R
BP-51 COIL OVER LH	BP5190014L
BP-51 FRONT FIT KIT	VM80010044
FIT KITS & HARDWARE	
UPPER CONTROL ARM (optional)	UCA0007
TRIM PACKER (if required)	OME95PF5

REAR SELECTION	
DESCRIPTION	PART NUMBER
LEAF SPRINGS	
CONSTANT 300kg	EL124R
CONSTANT 600kg	EL125R
EXTRA LEAF (if required)	EL39XL
SHOCKS	
NITROCHARGER SPORT	*60168 / 60167
NITROCHARGER PLUS	*63168 / 63167
BP-51	
BP-51 SHOCK REAR	BP5160050
BP-51 REAR FIT KIT	VM80010045
FIT KITS & HARDWARE	
U BOLTS	OMEU53A OMEU53B
SPRING BUSH KIT	OMESB120
GREASABLE BUSH KIT (optional)	OMESB119
GREASABLE SHACKLE KIT (optional)	OMEGS26
GREASABLE PIN KIT (optional)	OMEGP9
HANDBRAKE CABLE FIT KIT	FK66

NOTE: There is a choice of front and rear springs depending on the set up of the particular vehicle. Please read comments relating to fitment of components. For all information refer to the vehicle specific selection page.

GVM UPGRADE - MAZDA

BT-50 2021 ON 4X4 AND 4X2 HI-RIDER

AUSTRALIA ONLY

OE GVM		3100kg	FOR PRE REGISTERED VEHICLES ONLY		
Upgraded GVM		3500kg	SEATING CAPACITY: 2, 5		
RVSA Approval Number		VTA-060162	*SPECIAL REQUIREMENTS*		
Compliance Kit Number		BT50C3500	Minimum of 600kg permanently carried load at all times.		
		NOTE: Warning Labels, part numbers 215759/38/39, supplied with compliance kits. For specific placement locations refer to PIB Release No.1587			
Axle Loads	Front OE	1450kg	Front Upgraded	1595kg	
	Rear OE	1910kg	Rear Upgraded	2100kg	
VEHICLE VARIANTS - 4X4 AND 4X2 HI-RIDER					
DESCRIPTION	BODY STYLE	ENGINE	TRANSMISSION	TYRE DESIGNATION	RIM SIZE
Dual Cab	Utility	1.9 Diesel	Manual	255/65/R17	17x7J
		3.0 Diesel	Automatic	265/60/R18	18x7.5J
Dual Cab	Cab Chassis	3.0 Diesel	Manual	255/65/R17	17x7J
			Automatic		
Freestyle Cab	Utility	3.0 Diesel	Automatic	255/65/R17	17x7J
Freestyle Cab	Cab Chassis	3.0 Diesel	Manual	255/65/R17	17x7J
			Automatic		
Single Cab	Cab Chassis	3.0 Diesel	Manual Automatic	255/65/R17	17x7J

SUSPENSION SELECTION

FRONT SELECTION	
DESCRIPTION	PART NUMBER
NITROCHARGER SPORT	
NO ACCESSORIES	2883
BAR ONLY	3114
BAR & WINCH	2884
BAR/ WINCH & ACC	2885
STRUTS	*90046 / 90045
NITROCHARGER PLUS	
SPRING	4001
STRUTS	*93046 / 93045
BP-51	
BP-51 COIL OVER RH	BP5190014R
BP-51 COIL OVER LH	BP5190014L
BP-51 FRONT FIT KIT	VM80010044
FIT KITS & HARDWARE	
UPPER CONTROL ARM (optional)	UCA0007
TRIM PACKER (if required)	OME95PF5

REAR SELECTION	
DESCRIPTION	PART NUMBER
LEAF SPRINGS	
CONSTANT 600kg	EL125R
EXTRA LEAF (if required)	EL39XL
SHOCKS	
NITROCHARGER SPORT	*60169 / 60168
NITROCHARGER PLUS	*63169 / 63168
BP-51	
BP-51 SHOCK REAR	BP5160050
BP-51 REAR FIT KIT	VM80010045
FIT KITS & HARDWARE	
U BOLTS	OMEU53A OMEU53B
SPRING BUSH KIT	OMESB120
GREASABLE BUSH KIT (optional)	OMESB119
GREASABLE SHACKLE KIT (optional)	OMEGS26
GREASABLE PIN KIT (optional)	OMEGP9
HANDBRAKE CABLE FIT KIT	FK66

NOTE: There is a choice of front and rear springs depending on the set up of the particular vehicle. Please read comments relating to fitment of components. For all information refer to the vehicle specific selection page.

GVM UPGRADE - MAZDA

BT-50 2021 ON 4X4 AND 4X2 HI-RIDER

AUSTRALIA ONLY

OE GVM		3100kg	FOR PRE REGISTERED VEHICLES ONLY		
Upgraded GVM		3360kg			
RVSA Approval Number		VTA-060162			
Compliance Kit Number		BT50C3360			
SEATING CAPACITY: 2, 5					
Axle Loads	Front OE	1450kg	Front Upgraded	1450kg	
	Rear OE	1910kg	Rear Upgraded	1910kg	
VEHICLE VARIANTS - 4X4 AND 4X2 HI-RIDER					
DESCRIPTION	BODY STYLE	ENGINE	TRANSMISSION	TYRE DESIGNATION	RIM SIZE
Dual Cab	Utility	1.9 Diesel	Manual	255/65/R17	17x7J
		3.0 Diesel	Automatic	265/60/R18	18x7.5J
Dual Cab	Cab Chassis	3.0 Diesel	Manual	255/65/R17	17x7J
			Automatic		
Freestyle Cab	Utility	3.0 Diesel	Automatic	255/65/R17	17x7J
Freestyle Cab	Cab Chassis	3.0 Diesel	Manual	255/65/R17	17x7J
			Automatic		
Single Cab	Cab Chassis	3.0 Diesel	Manual Automatic	255/65/R17	17x7J

SUSPENSION SELECTION

FRONT SELECTION	
DESCRIPTION	PART NUMBER
NITROCHARGER SPORT	
NO ACCESSORIES	2883
BAR ONLY	3114
BAR & WINCH	2884
BAR/ WINCH & ACC	2885
SHOCKS	*93046 / 93045
NITROCHARGER PLUS	
SPRINGS	4001
STRUTS	*93046 / 93045
BP-51	
BP-51 COIL OVER RH	BP5190014R
BP-51 COIL OVER LH	BP5190014L
BP-51 FRONT FIT KIT	VM80010044
FIT KITS & HARDWARE	
UPPER CONTROL ARM (optional)	UCA0007
TRIM PACKER (if required)	OME95PF5

REAR SELECTION	
DESCRIPTION	PART NUMBER
LEAF SPRINGS	
CONSTANT 300kg	EL124R
CONSTANT 600kg	EL125R
EXTRA LEAF (if required)	EL39XL
SHOCKS	
NITROCHARGER SPORT	*60168 / 60167
NITROCHARGER PLUS	*63168 / 63167
BP-51	
BP-51 SHOCK REAR	BP5160050
BP-51 REAR FIT KIT	VM80010045
FIT KITS & HARDWARE	
U BOLTS	OMEU53A
	OMEU53B
SPRING BUSH KIT	OMESB120
GREASABLE BUSH KIT (optional)	OMESB119
GREASABLE SHACKLE KIT (optional)	OMEGS26
GREASABLE PIN KIT (optional)	OMEGP9
HANDBRAKE CABLE FIT KIT	FK66

NOTE: There is a choice of front and rear springs depending on the set up of the particular vehicle. Please read comments relating to fitment of components. For all information refer to the vehicle specific selection page.

GVM UPGRADE - TOYOTA

HILUX 2021 ON 4X4 ONLY - Not Hilux Rugged X / Rogue

AUSTRALIA ONLY

OE GVM		3050kg & 3100kg	FOR PRE REGISTERED VEHICLES ONLY		
Upgraded GVM		3465kg	SEATING CAPACITY: 2, 4, 5		
RVSA Approval Number		VTA-048108	*SPECIAL REQUIREMENTS* Minimum of 600kg permanently carried load at all times.		
Compliance Kit Number		HI3465	NOTE: Warning Labels, part numbers 215738/39/29, supplied with compliance kits. For specific placement locations refer to PIB No's. 318 & 1017.		
Axle Loads	Front OE	1450kg	Front Upgraded	1595kg	
	Rear OE	1700kg	Rear Upgraded	1870kg	
VEHICLE VARIANTS - 4X4 ONLY					
DESCRIPTION	BODY STYLE	ENGINE	TRANSMISSION	TYRE DESIGNATION	RIM SIZE
Double Cab	Utility	2.4/2.8 Diesel	Manual	265/65R17	17x7.5J
			Automatic	265/60R18	18x7.5J
Double Cab	Cab Chassis	2.4/2.8 Diesel	Manual	265/65R17	17x7.5J
			Automatic	265/60R18	18x7.5J
Extra Cab	Utility	2.8 Diesel	Automatic	265/65R17	17x7.5J
				265/60R18	18x7.5J
Extra Cab	Cab Chassis	2.4/2.8 Diesel	Manual	265/65R17	17x7.5J
			Automatic		
Single Cab	Cab Chassis	2.4/2.8 Diesel	Manual Automatic	225/70R17C	17x6J

SUSPENSION SELECTION

FRONT SELECTION	
DESCRIPTION	PART NUMBER
NITROCHARGER SPORT	
NO ACCESSORIES 40mm	2884
BAR ONLY 40mm	3176
BAR & WINCH 40mm	3190
BAR/ WINCH & ACC 40mm	3177
NO ACCESSORIES 20mm	3114
BAR ONLY 20mm	2885
BAR & WINCH 20mm	2887
BAR/ WINCH & ACC 20mm	2888
STRUTS	*90029 / 90028
NITROCHARGER PLUS / MT64	
SPRING 40mm	4000
SPRING 20mm	4007
STRUT - NITROCHARGER PLUS	*93029 / 93028
STRUT - MT64	MT64901001
BP-51	
BP-51 COIL OVER RH	BP5190007R
BP-51 COIL OVER LH	BP5190007L
BP-51 FRONT FIT KIT	VM80010018
FIT KITS & HARDWARE	
UPPER CONTROL ARM (optional)	UCA0003
TRIM PACKER (if required)	OME95PF5

REAR SELECTION		
DESCRIPTION	PART NUMBER	
LEAF SPRINGS		
CONSTANT 600kg	EL107R	
EXTRA LEAF (if required)	EL45XL	
SHOCKS		
NITROCHARGER SPORT	60133	
NITROCHARGER PLUS	63133	
MT64		
SHOCK - MT64	MT64601001L	MT64601001R
SHOCK - MT64 HEAVY	*MT64601002L	*MT64601002R
BP-51		
BP-51 SHOCK	BP5160018L	BP5160018R
BP-51 SHOCK HEAVY	*BP5160051L	*BP5160051R
BP-51 REAR FIT KIT	VM80010019	
FIT KITS & HARDWARE		
U BOLTS	OMEU53B	
SPRING BUSH KIT	OMESB98	
GREASABLE SHACKLE KIT (optional)	OMEGS25	
GREASABLE PIN KIT (optional)	OMEGP9	
HEADLAMP LEVELLING BRACKET	FK86	

NOTE: There is a choice of front and rear springs depending on the set up of the particular vehicle. Please read comments relating to fitment of components. For all information refer to the vehicle specific selection page.

GVM UPGRADE - TOYOTA

HILUX 2021 ON 4X4 ONLY - Not Hilux Rugged X / Rogue

AUSTRALIA ONLY

OE GVM		3050kg & 3100kg		FOR PRE REGISTERED VEHICLES ONLY	
Upgraded GVM		3180kg			
RVSA Approval Number		VTA-048108			
Compliance Kit Number		HI3180			
Axle Loads		Front OE	1450kg	Front Upgraded	1480kg
		Rear OE	1700kg	Rear Upgraded	1700kg
VEHICLE VARIANTS - 4X4 ONLY					
DESCRIPTION	BODY STYLE	ENGINE	TRANSMISSION	TYRE DESIGNATION	RIM SIZE
Double Cab	Utility	2.4/2.8 Diesel	Manual	265/65R17	17x7.5J
			Automatic	265/60R18	18x7.5J
Double Cab	Cab Chassis	2.4/2.8 Diesel	Manual	265/65R17	17x7.5J
			Automatic	265/60R18	18x7.5J
Extra Cab	Utility	2.8 Diesel	Automatic	265/65R17	17x7.5J
				265/60R18	18x7.5J
Extra Cab	Cab Chassis	2.4/2.8 Diesel	Manual	265/65R17	17x7.5J
			Automatic		
Single Cab	Cab Chassis	2.4/2.8 Diesel	Manual Automatic	225/70R17C	17x6J

SUSPENSION SELECTION

FRONT SELECTION	
DESCRIPTION	PART NUMBER
NITROCHARGER SPORT	
NO ACCESSORIES 40mm	2884
BAR ONLY 40mm	3176
BAR & WINCH 40mm	3190
BAR/ WINCH & ACC 40mm	3177
NO ACCESSORIES 20mm	3114
BAR ONLY 20mm	2885
BAR & WINCH 20mm	2887
BAR/ WINCH & ACC 20mm	2888
STRUTS	*90029 / 90028
NITROCHARGER PLUS / MT64	
SPRING 40mm	4000
SPRING 20mm	4007
STRUT - NITROCHARGER PLUS	*93029 / 93028
STRUT - MT64	MT64901001
BP-51	
BP-51 COIL OVER RH	BP5190007R
BP-51 COIL OVER LH	BP5190007L
BP-51 FRONT FIT KIT	VM80010018
FIT KITS & HARDWARE	
UPPER CONTROL ARM (optional)	UCA0003
TRIM PACKER (if required)	OME95PF5

REAR SELECTION		
DESCRIPTION	PART NUMBER	
LEAF SPRINGS		
CONSTANT 300kg	EL106R	
CONSTANT 600kg	EL107R	
EXTRA LEAF (if required)	EL45XL	
SHOCKS		
NITROCHARGER SPORT	*60132 / 60133	
NITROCHARGER PLUS	*63132 / 63133	
MT64		
SHOCK - MT64	MT64601001L	MT64601001R
SHOCK - MT64 HEAVY	*MT64601002L	*MT64601002R
BP-51		
BP-51 SHOCK	BP5160018L	BP5160018R
BP-51 SHOCK HEAVY	*BP5160051L	*BP5160051R
BP-51 REAR FIT KIT	VM80010019	
FIT KITS & HARDWARE		
U BOLTS	OMEU53A	
	OMEU53B	
SPRING BUSH KIT	OMESB98	
GREASABLE SHACKLE KIT (optional)	OMEGS25	
GREASABLE PIN KIT (optional)	OMEGP9	
HEADLAMP LEVELLING BRACKET	FK86	

NOTE: There is a choice of front and rear springs depending on the set up of the particular vehicle. Please read comments relating to fitment of components. For all information refer to the vehicle specific selection page.

GVM UPGRADE - TOYOTA

LANDCRUISER 300 SERIES

AUSTRALIA ONLY

OE GVM	3280kg	FOR PRE REGISTERED VEHICLES ONLY	
Upgraded GVM	3560kg	SEATING CAPACITY: 7 (GX,ZX,GR: 5)	
RVSA Approval Number	VTA-060708	*SPECIAL REQUIREMENTS*	
Compliance Kit Number	3003560	REVERSE LIGHT KIT IS REQUIRED	
		Reverse Light Kit - FK119 (Pair)	
		Reverse Light Harness - 6821449 (Each)	
Axle Loads	Front OE	1630kg	Front Upgraded
	Rear OE	1930kg	Rear Upgraded
		1630kg	1930kg
VEHICLE VARIANTS			
DESCRIPTION	BODY STYLE	ENGINE	TRANSMISSION
			TYRE DESIGNATION
			RIM SIZE
GX	Wagon	3.3 Diesel	Automatic
			245/75R17
			18x7J
			265/65R18
			18x7.5J
			265/55R20
			20x8J
All Others	Wagon	3.3 Diesel	Automatic
			265/65R18
			18x7.5J
			265/55R20
			20x8J

SUSPENSION SELECTION

FRONT SELECTION	
DESCRIPTION	PART NUMBER
NITROCHARGER SPORT	
NO ACCESSORIES	3215
BAR ONLY	3216
BAR & WINCH	3217
BAR/ WINCH & ACC	3218
STRUTS	*90055 / 90054
NITROCHARGER PLUS	
SPRING	4023
STRUTS	*93055 / 93054
BP-51	
BP-51 COIL OVER RH (NOT GR SPORT)	BP5190019R
BP-51 COIL OVER LH (NOT GR SPORT)	BP5190019L
BP-51 FRONT FIT KIT (NOT GR SPORT)	VM80010054
BP-51 COIL OVER RH (GR SPORT ONLY)	BP5190022R
BP-51 COIL OVER LH (GR SPORT ONLY)	BP5190022L
BP-51 FRONT FIT KIT (GR SPORT ONLY)	VM80010067
FIT KITS & HARDWARE	
UPPER CONTROL ARM (optional)	UCA0006
TRIM PACKER (if required)	OME95PF5

REAR SELECTION	
DESCRIPTION	PART NUMBER
SPRINGS	
MEDIUM LOAD	3219
CONSTANT 200kg	3220
CONSTANT 400kg	3221
CONSTANT 600kg	3222
SHOCKS	
NITROCHARGER SPORT	*60177 / 60176
NITROCHARGER PLUS	*63177 / 63176
BP-51	
BP-51 SHOCK (ALL MODELS)	BP5160061
BP-51 SHOCK (ALL MODELS)	*BP5160062
BP-51 REAR FIT KIT (NOT GR SPORT)	VM80010055
BP-51 REAR FIT KIT (GR SPORT ONLY)	VM80010066
FIT KITS & HARDWARE	
TRIM PACKER (if required)	OME80PR05
	OME80PR10
STONE GUARD KIT (recommended)	OME661

NOTE: There is a choice of front and rear springs depending on the set up of the particular vehicle. Please read comments relating to fitment of components. For all information refer to the vehicle specific selection page.

GVM UPGRADE - TOYOTA

LANDCRUISER 300 SERIES

AUSTRALIA ONLY

OE GVM		3280kg	FOR PRE REGISTERED VEHICLES ONLY		
Upgraded GVM		3650kg	SEATING CAPACITY: 5 & 7		
RVSA Approval Number		VTA-061113	*SPECIAL REQUIREMENTS*		
Compliance Kit Number		3003650	Minimum of 200kg permanently carried load at all times.		
		NOTE: Warning Labels, part numbers 215738/ 215739/ 215975/ 215981/ 215964, supplied with compliance kits.			
Axle Loads	Front OE	1630kg	Front Upgraded	1710kg	
	Rear OE	1930kg	Rear Upgraded	2025kg	
VEHICLE VARIANTS					
Description	Body Style	Engine	Transmission	Tyre	Rim Size
GX	Wagon	3.3 Diesel	Automatic	245/75R17	17X7J
All others	Wagon	3.3 Diesel	Automatic	265/65R18	18X7.5J

SUSPENSION SELECTION

FRONT SELECTION	
DESCRIPTION	PART NUMBER
NITROCHARGER SPORT	
NO ACCESSORIES	3215
BAR ONLY	3216
BAR & WINCH	3217
BAR/ WINCH & ACC	3218
STRUT	90055
NITROCHARGER PLUS	
SPRING	4023
STRUTS	93055
BP-51	
BP-51 COIL OVER RH	BP5190019R
BP-51 COIL OVER LH	BP5190019L
BP-51 KIT	VM80010054
BP-51 COIL OVER RH (GR Sport)	BP5190022R
BP-51 COIL OVER LH (GR Sport)	BP5190022L
BP-51 KIT (GR Sport)	VM80010067
FIT KITS & HARDWARE	
UPPER CONTROL ARM (optional)	UCA0006
TRIM PACKER (if required)	OME95PF5

REAR SELECTION	
DESCRIPTION	PART NUMBER
SPRINGS	
CONSTANT 200kg	3220
CONSTANT 400kg	3221
CONSTANT 600kg	3222
SHOCKS	
NITROCHARGER SPORT	60177
NITROCHARGER PLUS	63077
BP-51	
BP-51 SHOCK	BP5160062
BP-51 REAR FIT KIT	VM80010055
BP-51 REAR FIT KIT (GR Sport)	VM80010066
FIT KITS & HARDWARE	
TRIM PACKER (if required)	OME80PR05
	OME80PR10
STONE GUARD KIT (recommended)	OME661

MANDATORY COMPONENTS	
PART NUMBER	QUANTITY
REVERSE LIGHT KIT	
FK119	1
6821449	
CAT6 INDICATOR KIT	
OMELT0002	2
6821448	1
SPRING SEAT REINFORCEMENT KIT	
FK121	1

NOTE: There is a choice of front and rear springs depending on the set up of the particular vehicle. Please read comments relating to fitment of components. For all information refer to the vehicle selection page.

GVM UPGRADE - TOYOTA

LANDCRUISER 300 SERIES

AUSTRALIA ONLY

OE GVM		3280kg	FOR PRE REGISTERED VEHICLES ONLY		
Upgraded GVM		3920kg	SEATING CAPACITY: 5 & 7		
RVSA Approval Number		VTA-061113	*SPECIAL REQUIREMENTS*		
Compliance Kit Number		3003920	Minimum of 400kg permanently carried load at all times.		
		NOTE: Warning Labels, part numbers 215738/ 215739/ 215976/ 215981/ 215964, supplied with compliance kits.			
Axle Loads	Front OE	1630kg	Front Upgraded	1795kg	
	Rear OE	1930kg	Rear Upgraded	2125kg	
VEHICLE VARIANTS					
Description	Body Style	Engine	Transmission	Tyre	Rim Size
GX	Wagon	3.3 Diesel	Automatic	245/75R17	17X7J
All others	Wagon	3.3 Diesel	Automatic	265/65R18	18X7.5J

SUSPENSION SELECTION

FRONT SELECTION	
DESCRIPTION	PART NUMBER
NITROCHARGER SPORT	
NO ACCESSORIES	3215
BAR ONLY	3216
BAR & WINCH	3217
BAR/ WINCH & ACC	3218
STRUT	90055
NITROCHARGER PLUS	
SPRING	4023
STRUTS	93055
BP-51	
BP-51 COIL OVER RH	BP5190019R
BP-51 COIL OVER LH	BP5190019L
BP-51 KIT	VM80010054
BP-51 COIL OVER RH (GR Sport)	BP5190022R
BP-51 COIL OVER LH (GR Sport)	BP5190022L
BP-51 KIT (GR Sport)	VM80010067
FIT KITS & HARDWARE	
UPPER CONTROL ARM (optional)	UCA0006
TRIM PACKER (if required)	OME95PF5

REAR SELECTION	
DESCRIPTION	PART NUMBER
SPRINGS	
CONSTANT 400kg	3221
CONSTANT 600kg	3222
SHOCKS	
NITROCHARGER SPORT	60177
NITROCHARGER PLUS	63177
BP-51	
BP-51 SHOCK	BP5160062
BP-51 REAR FIT KIT	VM80010055
BP-51 REAR FIT KIT (GR Sport)	VM80010066
FIT KITS & HARDWARE	
TRIM PACKER (if required)	OME80PR05
	OME80PR10
STONE GUARD KIT (recommended)	OME661

MANDATORY COMPONENTS	
PART NUMBER	QUANTITY
REVERSE LIGHT KIT	
FK119	1
6821449	
CAT6 INDICATOR KIT	
OMELT0002	2
6821448	1
SPRING SEAT REINFORCEMENT KIT	
FK121	1

NOTE: There is a choice of front and rear springs depending on the set up of the particular vehicle. Please read comments relating to fitment of components. For all information refer to the vehicle selection page.

GVM UPGRADE - TOYOTA

LANDCRUISER 70 SERIES DUAL CAB - TECH PACK

AUSTRALIA ONLY

OE GVM		3300kg	FOR PRE REGISTERED VEHICLES ONLY		
Upgraded GVM		3950kg	SEATING CAPACITY: 5		
RVSA Approval Number		VTA-062507	*SPECIAL REQUIREMENTS*		
Compliance Kit Number		70T3950	Minimum of 600kg permanently carried load at all times.		
Compliance Kit Number		70T3950	NOTE: Warning Labels, part numbers 215738/39/87/88, supplied with compliance kits. For specific placement locations refer to PIB No's. 422 & 1017.		
Axle Loads	Front OE	1480kg	Front Upgraded	1540kg	
	Rear OE	2300kg	Rear Upgraded	2410kg	
VEHICLE VARIANTS - DUAL CAB 4 DOOR CAB CHASSIS					
DESCRIPTION	BODY STYLE	ENGINE	TRANSMISSION	TYRE DESIGNATION	RIM SIZE
70 Series Dual Cab	Cab Chassis	4.5 Turbo Diesel	Manual	225/95R16 265/70R16	16x6J 16x7JJ

SUSPENSION SELECTION

FRONT SELECTION	
DESCRIPTION	PART NUMBER
SPRINGS	
NO ACC or BAR ONLY	2856
BAR/ WINCH & ACC	2859
NITROCHARGER	
NITROCHARGER SPORT	60008
NITROCHARGER PLUS	63008
MT64	
SHOCK MT64 FRONT	MT64601003
BP-51	
BP-51 SHOCK FRONT	BP5160042
BP-51 FRONT FIT KIT	VM80010006
FIT KITS & HARDWARE	
STEERING DAMPER (optional)	OMESD47
CASTER KIT (if required)	OMECA77B
SWAY BAR SPACER KIT (if required)	FK19

REAR SELECTION	
DESCRIPTION	PART NUMBER
MULTI-LEAF SPRINGS	
CONSTANT 500/600kg	EL115R
CONSTANT 700/800kg	EL116R
EXTRA LEAF (if required)	EL14XL
NITROCHARGER	
NITROCHARGER SPORT	*60109 / 60011
NITROCHARGER PLUS	*63109 / 63011
MT64	
SHOCK MT64	MT64601005
SHOCK MT64 Heavy	*MT64601006
SHOCK MT64 Long	MT64601008
BP-51	
BP-51 SHOCK REAR SUITS EL115R	BP5160028
BP-51 SHOCK REAR SUITS EL116R	BP5160052
BP-51 REAR FIT KIT	VM80010007
FIT KITS & HARDWARE	
U BOLTS	OMEU59B OMEU59C
SPRING BUSH KIT	OMESB101
GREASABLE BUSH KIT (optional)	OMESB85
GREASABLE SHACKLE KIT (optional)	OMEGS10
GREASABLE SHACKLE END PIN KIT (optional)	OMEGP7
REAR SWAY BAR HD (MANDATORY)	OMESTAB9
SWAY BAR FIT KIT (MANDATORY)	FK76 FK77

NOTE: There is a choice of front and rear springs depending on the set up of the particular vehicle. Please read comments relating to fitment of components. For all information refer to the vehicle specific selection page.

GVM UPGRADE - TOYOTA

LANDCRUISER 70 SERIES DUAL CAB - TECH PACK

AUSTRALIA ONLY

OE GVM		3300kg	FOR PRE REGISTERED VEHICLES ONLY		
Upgraded GVM		3780kg	SEATING CAPACITY: 5		
RVSA Approval Number		VTA-062507			
Compliance Kit Number		70T3780			
Axle Loads	Front OE	1480kg	Front Upgraded	1480kg	
	Rear OE	2300kg	Rear Upgraded	2300kg	
VEHICLE VARIANTS - DUAL CAB 4 DOOR CAB CHASSIS					
DESCRIPTION	BODY STYLE	ENGINE	TRANSMISSION	TYRE DESIGNATION	RIM SIZE
70 Series Dual Cab	Cab Chassis	4.5 Turbo Diesel	Manual	7.5R 16 8PR 265/70R16LT 225/95R 16C	16x5.50F 16x7JJ 16x6J

SUSPENSION SELECTION

FRONT SELECTION	
DESCRIPTION	PART NUMBER
SPRINGS	
NO ACC or BAR ONLY	2856
BAR/ WINCH	2859
BAR/ WINCH & ACC	2853
NITROCHARGER	
NITROCHARGER SPORT	60008
NITROCHARGER PLUS	63008
MT64	
SHOCK MT64 FRONT	MT64601003
BP-51	
BP-51 SHOCK FRONT	BP5160042
BP-51 FRONT FIT KIT	VM80010006
FIT KITS & HARDWARE FRONT	
STEERING DAMPER (optional)	OMESD47
CASTER KIT (if required)	OMECA77B
SWAY BAR SPACER KIT (if required)	FK19

REAR SELECTION	
DESCRIPTION	PART NUMBER
MULTI-LEAF SPRINGS	
CONSTANT 300kg	EL114R
CONSTANT 500kg	EL115R
CONSTANT 700kg	EL116R
EXTRA LEAF (if required)	EL14XL
NITROCHARGER	
NITROCHARGER SPORT	*60109 / 60011
NITROCHARGER PLUS	*63109 / 63011
MT64	
SHOCK MT64	MT64601005
SHOCK MT64 Heavy	*MT64601006
SHOCK MT64 Long	MT64601008
BP-51	
BP-51 SHOCK REAR SUITS EL114R/ EL115R	BP5160028
BP-51 SHOCK REAR SUITS EL116R	BP5160052
BP-51 REAR FIT KIT	VM80010007

FIT KITS & HARDWARE REAR	
U BOLTS	OMEU59B
	OMEU59C
SPRING BUSH KIT	OMESB101
GREASABLE BUSH KIT (optional)	OMESB85
GREASABLE SHACKLE KIT (optional)	OMEGS10
GREASABLE SHACKLE END PIN KIT (optional)	OMEGP7
HEAVY DUTY REAR SWAY BAR (optional)	OMESTAB9
SWAY BAR FIT KIT (optional)	FK76
	FK77

NOTE: There is a choice of front and rear springs depending on the set up of the particular vehicle. Please read comments relating to fitment of components. For all information refer to the vehicle specific selection page.

GVM UPGRADE - TOYOTA

LANDCRUISER 79 SERIES - SINGLE CAB - TECH PACK AUSTRALIA ONLY

OE GVM		3400kg	FOR PRE REGISTERED VEHICLES ONLY		
Upgraded GVM		3950kg	SEATING CAPACITY: 2, 3		
RVSA Approval Number		VTA-062507	*SPECIAL REQUIREMENTS*		
Compliance Kit Number		79T3950	Minimum of 600kg permanently carried load at all times.		
Axle Loads		1480kg	NOTE: Warning Labels, part numbers 215738/39/87/88, supplied with compliance kits. For specific placement locations refer to PIB No's. 422 & 1017.		
	Front OE	1480kg	Front Upgraded	1540kg	
	Rear OE	2300kg	Rear Upgraded	2410kg	
VEHICLE VARIANTS - 2 DOOR CAB CHASSIS					
DESCRIPTION	BODY STYLE	ENGINE	TRANSMISSION	TYRE DESIGNATION	RIM SIZE
79 Series Single Cab	Cab Chassis	4.5 Turbo Diesel	Manual	225/95R16 265/70R16	16x6J 16x7JJ

SUSPENSION SELECTION

FRONT SELECTION	
DESCRIPTION	PART NUMBER
SPRINGS	
NO ACC or BAR ONLY	2856
BAR/ WINCH & ACC	2859
NITROCHARGER	
NITROCHARGER SPORT	60008
NITROCHARGER PLUS	63008
MT64	
SHOCK MT64 FRONT	MT64601003
BP-51	
BP-51 SHOCK FRONT	BP5160042
BP-51 FRONT FIT KIT	VM80010006
FIT KITS & HARDWARE	
STEERING DAMPER (optional)	OMESD47
CASTER KIT (if required)	OMECA77B
SWAY BAR SPACER KIT (if required)	FK19

NOTE: There is a choice of front and rear springs depending on the set up of the particular vehicle. Please read comments relating to fitment of components. For all information refer to the vehicle specific selection page.

REAR SELECTION	
DESCRIPTION	PART NUMBER
MULTI-LEAF SPRINGS	
CONSTANT 500/600kg	EL115R
CONSTANT 700/800kg	EL116R
EXTRA LEAF (if required)	EL14XL
NITROCHARGER	
NITROCHARGER SPORT	*60109 / 60011
NITROCHARGER PLUS	*63109 / 63011
MT64	
SHOCK MT64	MT64601005
SHOCK MT64 Heavy	*MT64601006
SHOCK MT64 Long	MT64601008
BP-51	
BP-51 SHOCK REAR SUITS EL114R/ EL115R	BP5160028
BP-51 SHOCK REAR SUITS EL116R	BP5160052
BP-51 REAR FIT KIT	VM80010007
FIT KITS & HARDWARE	
U BOLTS	OMEU59B OMEU59C
SPRING BUSH KIT	OMESB101
GREASABLE BUSH KIT (optional)	OMESB85
GREASABLE SHACKLE KIT (optional)	OMEGS10
GREASABLE SHACKLE END PIN KIT (optional)	OMEGP7
HEAVY DUTY REAR SWAY BAR (MANDATORY)	OMESTAB9
SWAY BAR FIT KIT (MANDATORY)	FK76 FK77

GVM UPGRADE - TOYOTA

LANDCRUISER 79 SERIES - SINGLE CAB - TECH PACK AUSTRALIA ONLY

OE GVM		3400kg	FOR PRE REGISTERED VEHICLES ONLY		
Upgraded GVM		3780kg	SEATING CAPACITY: 2, 3		
RVSA Approval Number		VTA-062507			
Compliance Kit Number		79T3780			
Axle Loads	Front OE	1480kg	Front Upgraded	1480kg	
	Rear OE	2300kg	Rear Upgraded	2300kg	
VEHICLE VARIANTS - 2 DOOR CAB CHASSIS					
DESCRIPTION	BODY STYLE	ENGINE	TRANSMISSION	TYRE DESIGNATION	RIM SIZE
79 Series	Cab Chassis	4.5 Turbo Diesel	Manual	7.5R 16 8PR 265/70R16LT 225/95R 16C	16x5.50F 16x7JJ 16x6J

SUSPENSION SELECTION

FRONT SELECTION	
DESCRIPTION	PART NUMBER
SPRINGS	
NO ACC or BAR ONLY	2856
BAR/ WINCH	2859
BAR/ WINCH & ACC	2853
NITROCHARGER	
NITROCHARGER SPORT	60008
NITROCHARGER PLUS	63008
MT64	
SHOCK MT64 FRONT	MT64601003
BP-51	
BP-51 SHOCK FRONT	BP5160042
BP-51 FRONT FIT KIT	VM80010006
FIT KITS & HARDWARE	
STEERING DAMPER (optional)	OMESD47
CASTER KIT (if required)	OMECA77B
SWAY BAR SPACER KIT (if required)	FK19

NOTE: There is a choice of front and rear springs depending on the set up of the particular vehicle. Please read comments relating to fitment of components. For all information refer to the vehicle specific selection page.

REAR SELECTION	
DESCRIPTION	PART NUMBER
LEAF SPRINGS	
CONSTANT 400kg	EL114R
CONSTANT 600kg	EL115R
CONSTANT 800kg	EL116R
EXTRA LEAF (if required)	EL14XL
NITROCHARGER	
NITROCHARGER SPORT	*60109 / 60011
NITROCHARGER PLUS	*63109 / 63011
MT64	
SHOCK MT64	MT64601005
SHOCK MT64 Heavy	*MT64601006
SHOCK MT64 Long	MT64601008
BP-51	
BP-51 SHOCK REAR SUITS EL114R/ EL115R	BP5160028
BP-51 SHOCK REAR SUITS EL116R	BP5160052
BP-51 REAR FIT KIT	VM80010007
FIT KITS & HARDWARE	
U BOLTS	OMEU59B OMEU59C
SPRING BUSH KIT	OMESB101
GREASABLE BUSH KIT (optional)	OMESB85
GREASABLE SHACKLE KIT (optional)	OMEGS10
GREASABLE SHACKLE END PIN KIT (optional)	OMEGP7
HEAVY DUTY REAR SWAY BAR (optional)	OMESTAB9
SWAY BAR FIT KIT (optional)	FK76 FK77

HISTORICAL REFERENCE - GVM UPGRADE - FORD

RANGER PXIII 4X4 AND 4X2 HI-RIDER

AUSTRALIA ONLY

OE GVM	3200kg	FOR PRE REGISTERED VEHICLES ONLY			
Upgraded GVM	3500kg	SEATING CAPACITY: 2, 3, 4, 5			
RVSA Approval Number	VTA-044118	*SPECIAL REQUIREMENTS*			
Compliance Kit Number	PX3500	Minimum of 600kg permanently carried load at all times.			
NOTE: Warning Labels, part numbers 215738/215739/215752, supplied with compliance kits.					
VEHICLE VARIANTS 4X4 & 4X2 HI-RIDER					
DESCRIPTION	BODY STYLE	ENGINE	TRANSMISSION	TYRE DESIGNATION	RIM SIZE
Dual Cab	Utility	2.2 Diesel	Manual	255/70R16	16x7J
		3.2 Diesel	Automatic	265/65R17	17x7.5J
		2.0 Diesel		265/60R18	18x8J
Dual Cab	Cab Chassis	2.2 Diesel	Manual	255/70R16	16x7J
		3.2 Diesel	Automatic	265/65R17	17x7.5J
				265/60R18	18x8J
Super Cab	Utility	2.0 Diesel	Manual	255/70R16	16x7J
		2.2 Diesel	Automatic	265/65R17	17x7.5J
		3.2 Diesel			
Super Cab	Cab Chassis	3.2 Diesel	Manual	255/70R16	16x7J
		2.2 Diesel	Automatic	265/65R17	17x7.5J
Single Cab	Cab Chassis	2.2 Diesel	Manual	255/70R16	16x7J
		3.2 Diesel	Automatic	265/65R17	17x7.5J

SUSPENSION SELECTION

FRONT SELECTION	
DESCRIPTION	PART #
SPRINGS	
NO ACCESSORIES	3141
BAR ONLY	3142
BAR & WINCH	3143
NO ACC 30MM LIFT	3140
STRUTS	
NITROCHARGER SPORT	90038
	90039
BP-51	
BP-51 COIL OVER RH	BP5190012R
BP-51 COIL OVER LH	BP5190012L
BP-51 FRONT FIT KIT	VM80010040
FIT KITS & HARDWARE	
UPPER CONTROL ARM (optional)	UCA0002
TRIM PACKER (if required)	FK94

REAR SELECTION	
DESCRIPTION	
LEAF SPRINGS	
CONSTANT 600kg	EL128R
EXTRA LEAF (if required)	EL34XL
SHOCKS	
NITROCHARGER SPORT	60102
BP-51	
BP-51 SHOCK RH	BP5160037R
BP-51 SHOCK LH	BP5160037L
BP-51 REAR FIT KIT	VM80010012
FIT KITS & HARDWARE	
U BOLTS	OMEU66A
	OMEU66B
GREASEABLE SHACKLE BUSH KIT (optional)	OMESB118
SPRING BUSH KIT	OMESB117
GREASABLE SHACKLE KIT (optional)	OMEGS20
GREASABLE PIN KIT (optional)	OMEGP10
DRIVELINE SPACER KIT	FK57
LEAF SPRING F EYE BOLT KIT (optional)	FK95
LEAF SPRING ISOLATOR 2PK (optional)	FK103

HISTORICAL REFERENCE - GVM UPGRADE - FORD

RANGER PXIII 2018 ON 4X4 AND 4X2 HI-RIDER

AUSTRALIA ONLY

OE GVM	3200kg	FOR PRE REGISTERED VEHICLES ONLY			
Upgraded GVM	3330kg				
RVSA Approval Number	VTA-044118	SEATING CAPACITY: 2, 3, 4, 5			
Compliance Kit Number	PX3330				
VEHICLE VARIANTS 4X4 & 4X2 HI-RIDER					
DESCRIPTION	BODY STYLE	ENGINE	TRANSMISSION	TYRE DESIGNATION	RIM SIZE
Dual Cab	Utility	2.2 Diesel	Manual	255/70R16	16x7J
		3.2 Diesel	Automatic	265/65R17	17x7.5J
		2.0 Diesel		265/60R18	18x8J
Dual Cab	Cab Chassis	2.2 Diesel	Manual	255/70R16	16x7J
		3.2 Diesel	Automatic	265/65R17	17x7.5J
				265/60R18	18x8J
Super Cab	Utility	3.2 Diesel	Manual	255/70R16	16x7J
		2.2 Diesel	Automatic	265/65R17	17x7.5J
		2.0 Diesel			
Super Cab	Cab Chassis	3.2 Diesel	Manual	255/70R16	16x7J
		2.2 Diesel	Automatic	265/65R17	17x7.5J
Single Cab	Cab Chassis	2.2 Diesel	Manual	255/70R16	16x7J
		3.2 Diesel	Automatic	265/65R17	17x7.5J

SUSPENSION SELECTION

FRONT SELECTION	
DESCRIPTION	PART #
SPRINGS	
NO ACCESSORIES	3141
BAR ONLY	3142
BAR & WINCH	3143
NO ACC 30MM LIFT	3140
STRUTS	
NITROCHARGER SPORT	90038
	90039
BP-51	
BP-51 COIL OVER RH	BP5190012R
BP-51 COIL OVER LH	BP5190012L
BP-51 FRONT FIT KIT	VM80010040
FIT KITS & HARDWARE	
UPPER CONTROL ARM (optional)	UCA0002
TRIM PACKER (if required)	FK94

REAR SELECTION	
DESCRIPTION	PART #
LEAF SPRINGS	
CONSTANT 300kg	EL127R
CONSTANT 600kg	EL128R
EXTRA LEAF (if required)	EL34XL
SHOCKS	
NITROCHARGER SPORT	60101
	60102
BP-51	
BP-51 SHOCK RH	*BP5160037R
BP-51 SHOCK LH	*BP5160037L
BP-51 REAR FIT KIT	VM80010012
FIT KITS & HARDWARE	
U BOLTS	OMEU66A
	OMEU66B
GREASEABLE SHACKLE BUSH KIT (optional)	OMESB118
SPRING BUSH KIT	OMESB117
GREASABLE SHACKLE KIT (optional)	OMEGS20
GREASABLE PIN KIT (optional)	OMEGP10
DRIVELINE SPACER KIT	FK57
LEAF SPRING F EYE BOLT KIT (optional)	FK95
LEAF SPRING ISOLATOR 2PK (optional)	FK103

HISTORICAL REFERENCE - GVM UPGRADE - FORD

(Catalogue 38 09/2018)

RANGER PX/ II/ III 4X4 AND 4X2 HI-RIDER

AUSTRALIA ONLY

OE GVM 3200kg FOR PRE REGISTERED VEHICLES ONLY

Upgraded GVM *3500kg SEATING CAPACITY: 2, 3, 4, 5

ADR Approval Number 44118

***SPECIAL REQUIREMENTS:**

Minimum of 600kg permanently carried load.

NOTE: Warning Labels, part numbers 215727¹/8¹/31/8/9, supplied with compliance kits. For specific placement locations refer to PIB No. 318

VEHICLE VARIANTS 4X4 & 4X2 HI-RIDER

DESCRIPTION	BODY STYLE	ENGINE	TRANSMISSION	TYRE DESIGNATION	RIM SIZE
Dual Cab	Utility	2.2 Diesel	Manual	225/70R16	16x7J
		3.2 Diesel	Automatic	265/65R17	17x7.5J
				265/60R18	18x8J
Dual Cab	Cab Chassis	2.2 Diesel	Manual	255/70R16	16x7J
		3.2 Diesel	Automatic	265/65R17	17x7.5J
				265/60R18	18x8J
Super Cab	Utility	3.2 Diesel	Manual	255/70R16	16x7J
			Automatic	265/65R17	17x7.5J
Super Cab	Cab Chassis	3.2 Diesel	Manual	255/70R16	16x7J
			Automatic	265/65R17	17x7.5J
Single Cab	Cab Chassis	2.2 Diesel	Manual	255/70R16	16x7J
			Automatic	265/65R17	17x7.5J
		3.2 Diesel	Automatic	265/60R18	18x8J

SUSPENSION SELECTION

DESCRIPTION	PART NUMBER
PXII RANGER COMPLIANCE KIT	PX3500

FRONT COILS	
NO ACCESSORIES	2997
BAR ONLY	2998
BAR & WINCH	2999
NO ACCESSORIES 30MM LIFT	3048
BP-51 COIL OVER RIGHT	BP5190005R
BP-51 COIL OVER LEFT	BP5190005L
BP-51 FRONT FIT KIT	VM80010011
FRONT STRUTS	90019 ¹
	90020 ¹
TRIM PACKER (optional)	FK56

DESCRIPTION	PART NUMBER
REAR LEAF SPRINGS	
CONSTANT 600kg	EL069R ¹
EXTRA LEAF (if required)	EL34XL
BP-51 SHOCK RH	BP5160027R
BP-51 SHOCK LH	BP5160027L
BP-51 REAR FIT KIT	VM80010012
REAR SHOCK	60102 ¹
U BOLTS	OMEU66A
	OMEU66B
GREASEABLE SHACKLE BUSH KIT	OMESB103
GREASABLE SHACKLE KIT (optional)	OMEGS20
DRIVELINE SPACER KIT	FK57

1. When remaining stock of 215727, 215728, 60102, 90019, 90020, EL069R and EL104R is exhausted no further product will be available.

HISTORICAL REFERENCE - GVM UPGRADE - FORD

(Catalogue 28.2 05/2013)

RANGER PX/ II/ III 2011 ON

AUSTRALIA ONLY

OE GVM 3200kg

Upgraded GVM 3330kg

ADR Approval Number 44118

VEHICLE VARIANTS

DESCRIPTION	BODY STYLE	ENGINE	TRANSMISSION	TYRE DESIGNATION	RIM SIZE
Dual Cab	Utility	2.2 Diesel	Manual	225/70R16	16x7J
		3.2 Diesel	Automatic	265/65R17	17x7.5J
				265/60R18	18x8J
Dual Cab	Cab Chassis	2.2 Diesel	Manual	255/70R16	16x7J
		3.2 Diesel	Automatic	265/65R17	17x7.5J
				265/60R18	18x8J
Super Cab	Utility	3.2 Diesel	Manual	255/70R16	16x7J
			Automatic	265/65R17	17x7.5J
Super Cab	Cab Chassis	2.2 Diesel	Manual	255/70R16	16x7J
			3.2 Diesel	Automatic	265/65R17
Single Cab	Utility	2.2 Diesel		Manual	255/70R16
			3.2 Diesel	Automatic	265/65R17
					265/60R18
Single Cab	Cab Chassis	2.2 Diesel	Manual	255/70R16	16x7J
			3.2 Diesel	Automatic	265/65R17
		265/60R18		18x8J	

SUSPENSION SELECTION

DESCRIPTION	PART NUMBER
PX RANGER COMPLIANCE KIT	PX3330

FRONT COILS	
BAR ONLY	2998
BAR & WINCH	2999
FRONT STRUT	90019 ¹
	90020 ¹
TRIM PACKER (if required)	FK56

DESCRIPTION	PART NUMBER
REAR LEAF SPRINGS	
CONSTANT 300kg	CS068R ¹ / EL068R ¹
CONSTANT 600kg	CS069R ¹ / EL069R ¹
EXTRA LEAF (if required)	D34XL / EL34XL
REAR SHOCKS	60101 ¹
	60102 ¹
U BOLTS	OMEU66A
	OMEU66B
SPRING BUSH KIT	OMESB102
GREASABLE SHACKLE KIT (optional)	OMEGS20
GREASEABLE SHACKLE BUSH KIT (optional)	OMESB103
DRIVELINE SPACER KIT (optional)	FK57
CENTRE BOLT	UCB19

1. When remaining stock of 60101, 60102, 90019, 90020, CS068R, CS069R EL068R, EL069R, EL103R and EL104R is exhausted no further product will be available.

HISTORICAL REFERENCE - GVM UPGRADE - HOLDEN

COLORADO - ONLY

AUSTRALIA ONLY

OE GVM	3150kg	FOR PRE REGISTERED VEHICLES ONLY			
Upgraded GVM	3300kg				
RVSA Approval Number	49496	SEATING CAPACITY: 2, 4, 5			
Compliance Kit Number	HC3300¹				
VEHICLE VARIANTS 4X4 & 4X2 HI-RIDER					
DESCRIPTION	BODY STYLE	ENGINE	TRANSMISSION	TYRE DESIGNATION	RIM SIZE
Crew Cab	Pickup	2.8 Diesel	Manual	245/70R16	16x6.5J
			Automatic	255/65R17 265/60R18	17x7.0J 18x7.5J
Crew Cab	Cab Chassis	2.8 Diesel	Manual	245/70R16	16x6.5J
			Automatic	265/60R18	18x7.5J
Space Cab	Pickup	2.8 Diesel	Manual Automatic	265/60R18	18x7.5J
Super Cab	Cab Chassis	2.8 Diesel	Manual	245/70R16	16x6.5J
			Automatic		
Single Cab	Cab Chassis	2.8 Diesel	Manual	245/70R16	16x6.5J

SUSPENSION SELECTION

FRONT SELECTION	
DESCRIPTION	PART #
SPRINGS	
NO ACCESSORIES	3057
BAR ONLY	2883
BAR & WINCH	2869
BAR/ WINCH & ACC	3114
STRUTS	
NITROCHARGER SPORT	90022 ¹
	90023 ¹
BP-51	
BP-51 COIL OVER RH	BP5190009R
BP-51 COIL OVER LH	BP5190009L
BP-51 FRONT FIT KIT	VM80010030
FIT KITS & HARDWARE	
TRIM PACKER (if required)	OME95PF5

REAR SELECTION	
DESCRIPTION	PART #
LEAF SPRINGS	
MULTI LEAF	
CONSTANT 300kg	EL109R
CONSTANT 600kg	EL110R
EXTRA LEAF (if required)	EL39XL
SHOCKS	
NITROCHARGER SPORT	60116 ¹
	60117 ¹
BP-51	
BP-51 SHOCK LH	BP5160016
BP-51 SHOCK RH	BP5160048
BP-51 REAR FIT KIT	VM80010031
FIT KITS & HARDWARE	
U BOLTS	OMEU53A
	OMEU53B
SPRING BUSH KIT	OMESB98
	OMESB107
GREASABLE SHACKLE KIT (optional)	OMEGS14
GREASABLE PIN KIT (optional)	OMEGP9
HANDBRAKE CABLE FIT KIT	FK87

1. When remaining stock of 60116, 60117, 90022, 90023 and HC3300 is exhausted no further product will be available.

HISTORICAL REFERENCE - GVM UPGRADE - HOLDEN

COLORADO 2012 ON (Catalogue 29.1 04/2015)

AUSTRALIA ONLY

OE GVM 3100kg SEATING CAPACITY: 2, 3, 4, 5

Upgraded GVM 3235kg

ADR Approval Number

VEHICLE VARIANTS

DESCRIPTION	BODY STYLE	ENGINE	TRANSMISSION	TYRE DESIGNATION	RIM SIZE
Crew Cab	Pick Up	2.8 Diesel	Manual	255/65R17	17x7J
			Automatic	245/70R16	16x6.5J
Crew Cab	Cab Chassis	2.8 Diesel	Manual	245/70R16	16x6.5J
			Automatic		
Space Cab	Pick Up	2.8 Diesel	Manual	255/65R17	17x7J
			Automatic	245/70R16	16x6.5J
Space Cab	Cab Chassis	2.8 Diesel	Manual	245/70R16	16x6.5J
			Automatic		
Single Cab	Cab Chassis	2.8 Diesel	Manual Automatic	245/70R16	16x6.5J

SUSPENSION SELECTION

DESCRIPTION	PART NUMBER
COLORADO COMPLIANCE KIT	HC3235

FRONT COILS	
BAR ONLY	3057
BAR & WINCH	3058
FRONT STRUT	90022 ¹
	90023 ¹
TRIM PACKER (if required)	OME95PF5

DESCRIPTION	PART NUMBER
REAR LEAF SPRINGS	
CONSTANT 300kg	EL073R ¹
CONSTANT 600kg	EL074R ¹
EXTRA LEAF (if required)	EL39XL
REAR SHOCKS	60116 ¹
	60117 ¹
U BOLTS	OMEU53A
SPRING BUSH KIT	OMESB107
GREASABLE SHACKLE KIT (optional)	OMEGS14
GREASEABLE SHACKLE BUSH KIT (optional)	OMESB98

1. When remaining stock of 60116, 60117, 90022, 90023, EL073R and EL074R is exhausted no further product will be available.

HISTORICAL REFERENCE - GVM UPGRADE - ISUZU

DMAX 2012 ON (Catalogue 29.1 04/2015)

AUSTRALIA ONLY

OE GVM	2950kg	SEATING CAPACITY: 2, 4, 5
Upgraded GVM	3220kg	
ADR Approval Number	44897	

VEHICLE VARIANTS

DESCRIPTION	BODY STYLE	ENGINE	TRANSMISSION	TYRE DESIGNATION	RIM SIZE
Crew Cab	Utility	3.0 Diesel	Manual Automatic	255/65R17 245/70R16	17x7J 16x7J
Crew Cab	Cab Chassis	3.0 Diesel	Manual Automatic	245/70R16	16x7J
Space Cab	Utility	3.0 Diesel	Manual Automatic	255/65R17	17x7J
Space Cab	Cab Chassis	3.0 Diesel	Manual Automatic	245/70R16	16x7J
Single Cab	Cab Chassis	3.0 Diesel	Manual Automatic	245/70R16	16x7J

SUSPENSION SELECTION

DESCRIPTION	PART NUMBER
DMAX COMPLIANCE KIT	DM3220 ¹

FRONT COILS	
BAR ONLY	3057
BAR & WINCH	3058
FRONT STRUT	90022 ¹
	90023 ¹
TRIM PACKER (if required)	OME95PF5

DESCRIPTION	PART NUMBER
REAR LEAF SPRINGS	
CONSTANT 300kg	EL073R ¹
CONSTANT 600kg	EL074R ¹
EXTRA LEAF (if required)	EL39XL
REAR SHOCKS	60116 ¹
	60117 ¹
U BOLTS	OMEU53A
SPRING BUSH KIT	OMESB107
GREASABLE SHACKLE KIT (optional)	OMEGS14
GREASEABLE SHACKLE BUSH KIT (optional)	OMESB98

1. When remaining stock of 60116, 60117, 90022, 90023, DM3220, EL073R and EL074R is exhausted no further product will be available.

HISTORICAL REFERENCE - GVM UPGRADE - MAZDA

(Catalogue 40 07/2019)

BT-50 2011 ON 4X4 ONLY

AUSTRALIA ONLY

OE GVM 3200kg FOR PRE REGISTERED VEHICLES ONLY

Upgraded GVM *3500kg SEATING CAPACITY: 2, 3, 4, 5

ADR Approval Number 44120

***SPECIAL REQUIREMENTS:**

Minimum of 600kg permanently carried load.

NOTE: Warning Labels, part numbers 215727¹/8¹/32/38/39, supplied with compliance kits. For specific placement locations refer to PIB No. 318

VEHICLE VARIANTS - 4X4 ONLY

DESCRIPTION	BODY STYLE	ENGINE	TRANSMISSION	TYRE DESIGNATION	RIM SIZE
Dual Cab	Utility	3.2 Diesel	Manual	255/70R16	16x7J
			Automatic	265/65R17	17x7.5J
Dual Cab	Cab Chassis	3.2 Diesel	Manual	255/70R16	16x7J
			Automatic	265/65R17	17x7.5J
Freestyle Cab	Utility	3.2 Diesel	Manual	255/70R16	16x7J
			Automatic	265/65R17	17x7.5J
Freestyle Cab	Cab Chassis	3.2 Diesel	Manual	255/70R16	16x7J
			Automatic	265/65R17	17x7.5J
Single Cab	Cab Chassis	3.2 Diesel	Manual	255/70R16	16x7J
			Automatic	265/65R17	17x7.5J

SUSPENSION SELECTION

DESCRIPTION	PART NUMBER
BT-50 COMPLIANCE KIT	BT503500 ¹

FRONT COILS	
NO ACCESSORIES	2997
BAR ONLY	2998
BAR & WINCH	2999
NO ACCESSORIES 30MM LIFT	3048
FRONT STRUTS	90019 ¹
	90020 ¹
BP-51 COIL OVER RH	BP5190005R
BP-51 COIL OVER LH	BP5190005L
BP-51 KIT	VM80010011
TRIM PACKER (if required)	FK56

DESCRIPTION	PART NUMBER
REAR LEAF SPRINGS	
CONSTANT 600kg	EL069R ¹
EXTRA LEAF (if required)	EL34XL
BP-51 SHOCK RH	*BP5160037R / BP5160027R
BP-51 SHOCK LH	*BP5160037L / BP5160027L
BP-51 KIT REAR	VM80010019
REAR SHOCK	60102 ¹
U BOLTS	OMEU66A
	OMEU66B
GREASEABLE SHACKLE BUSH KIT	OMESB103
GREASABLE SHACKLE KIT (optional)	OMEGS20
DRIVELINE SPACER KIT (optional)	FK57

1. When remaining stock of 215727, 215728, 60102, 90019, 90020, BT503500, EL069R and EL104R is exhausted no further product will be available.

HISTORICAL REFERENCE - GVM UPGRADE - MAZDA

(Catalogue 28.2 05/2013)

BT-50 2011 ON

AUSTRALIA ONLY

OE GVM 3200kg

Upgraded GVM 3330kg

ADR Approval Number 44120

VEHICLE VARIANTS

DESCRIPTION	BODY STYLE	ENGINE	TRANSMISSION	TYRE DESIGNATION	RIM SIZE
Dual Cab	Utility	3.2 Diesel	Manual	225/70R16	16x7J
			Automatic	265/65R17	17x7.5J
Dual Cab	Cab Chassis	3.2 Diesel	Manual	255/70R16	16x7J
			Automatic	265/65R17	17x7.5J
Freestyle Cab	Utility	3.2 Diesel	Manual	255/70R16	16x7J
			Automatic	265/65R17	17x7.5J
Freestyle Cab	Cab Chassis	3.2 Diesel	Manual	255/70R16	16x7J
			Automatic	265/65R17	17x7.5J

SUSPENSION SELECTION

DESCRIPTION	PART NUMBER
BT-50 COMPLIANCE KIT	BT503330 ¹

FRONT COILS

BAR ONLY	2998
BAR & WINCH	2999
FRONT STRUT	90019 ¹
	90020 ¹
TRIM PACKER (if required)	FK56

DESCRIPTION	PART NUMBER
REAR LEAF SPRINGS	
CONSTANT 300kg	CS068R ¹ / EL068R ¹
CONSTANT 600kg	CS069R ¹ / EL069R ¹
EXTRA LEAF (if required)	D34XL / EL34XL
REAR SHOCKS	60101 ¹
	60102 ¹
U BOLTS	OMEU66A OMEU66B
SPRING BUSH KIT	OMESB102
GREASABLE SHACKLE KIT (optional)	OMEGS20
GREASEABLE SHACKLE BUSH KIT (optional)	OMESB103
DRIVELINE SPACER KIT (optional)	FK57
CENTRE BOLT	UCB19

1. When remaining stock of 60101, 60102, 90019, 90020, BT503330, CS068R, CS069R, EL068R, EL069R, EL103R and EL104R is exhausted no further product will be available.

HISTORICAL REFERENCE - GVM UPGRADE - NISSAN

(Catalogue 31 12/2015)

PATROL Y61 CAB CHASSIS LEAF SPRING

AUSTRALIA ONLY

OE GVM 3400kg

Upgraded GVM 3700kg

3900kg

** only applicable for models with 7.5R16LT tyres.

ADR Approval Number 24892

**Category 6 Side Indicators required for both 3700kg and 3900kg upgrades.

VEHICLE VARIANTS

DESCRIPTION	BODY STYLE	ENGINE	TRANSMISSION	TYRE DESIGNATION	RIM SIZE
DX Leaf	Cab Chassis	3.0 Diesel	Manual	7.5R16LT 265/75R16	5.50x16 16x8JJ

SUSPENSION SELECTION

DESCRIPTION	PART NUMBER
COMPLIANCE KIT 3700KG	GU3700 ¹
COMPLIANCE KIT 3900KG	GU3900
CATEGORY 6 SIDE INDICATORS	13.1049.000 ¹

FRONT COILS	
50mm LIFT TO 50KG	2973
50mm LIFT 51 TO 110KG	2970
20mm LIFT TO 50KG	2974
20mm LIFT 51 TO 110KG	2972
FRONT SHOCKS	60055
	N19 ¹
CASTER KIT (if required)	OMECA77B

DESCRIPTION	PART NUMBER
REAR LEAF SPRINGS	
CONSTANT 400KG	CS016RA/B
REAR SHOCKS	60054
	N25 ¹
SPRING BUSH KIT	OMESB64
ANTI INVERSION KIT	FK08
GREASABLE SHACKLE KIT (optional)	OMEGS1
GREASABLE FIXED END KIT (optional)	OMEGP2
BUMP STOP EXTENSION KIT (optional)	FK41
U BOLT	OMEU64
BRAKE PROPORTIONING BRACKET	FK78

1. When remaining stock of GU3700, 13.1049.000, N19 and N25 is exhausted no further product will be available.

GVM UPGRADE - TOYOTA

HILUX 21 TO 23 4X4 ONLY - ONLY For HiLux Rugged X/Rogue AUSTRALIA ONLY

OE GVM	3050kg	FOR PRE REGISTERED VEHICLES ONLY	
Upgraded GVM	3465kg	SEATING CAPACITY: 5	
RVSA Approval Number	VTA-051233	*SPECIAL REQUIREMENTS* Minimum of 600kg permanently carried load at all times.	
Compliance Kit Number	HI3465	NOTE: Warning Labels, part numbers 215738/39/29, supplied with compliance kits.	
Axle Loads	Front OE	1450kg	Front Upgraded
	Rear OE	1700kg	Rear Upgraded
			1595kg
			1870kg

VEHICLE VARIANTS - 4X4 ONLY

DESCRIPTION	BODY STYLE	ENGINE	TRANSMISSION	TYRE DESIGNATION	RIM SIZE
Double Cab	Utility	2.8 Diesel	Automatic	265/60R18	18x7.5J
Double Cab Rogue	Utility	2.8 Diesel	Automatic	265/60R18	18x7.5J
Double Cab Rugged X	Utility	2.8 Diesel	Automatic	265/60R18	18x7.5J

SUSPENSION SELECTION

FRONT SELECTION	
DESCRIPTION	PART NUMBER
SPRINGS - 20mm	
NO ACCESSORIES	3114
BAR ONLY	2885
BAR & WINCH	2887
BAR/ WINCH & ACC	2888
SPRINGS - 40mm	
NO ACCESSORIES	2884
BAR ONLY	3176
BAR & WINCH	3190
BAR/ WINCH & ACC	3177
NITROCHARGER SPORT	
STRUTS	90028
	90029
BP-51	
BP-51 COIL OVER RH	BP5190007R
BP-51 COIL OVER LH	BP5190007L
BP-51 FRONT FIT KIT	VM80010018
FIT KITS & HARDWARE	
UPPER CONTROL ARM (optional)	UCA0003
TRIM PACKER (if required)	OME95PF5

REAR SELECTION	
DESCRIPTION	PART NUMBER
LEAF SPRINGS	
CONSTANT 600kg	EL107R
EXTRA LEAF (if required)	EL45XL
NITROCHARGER SPORT	
SHOCKS	60133
BP-51	
BP-51 SHOCK RH	BP5160018R
	*BP5160051R
BP-51 SHOCK LH	BP5160018L
	*BP5160051L
BP-51 REAR FIT KIT	VM80010019
	VM80010019
FIT KITS & HARDWARE	
U BOLTS	OMEU53B
SPRING BUSH KIT	OMESB98
GREASABLE SHACKLE KIT (optional)	OMEGS25
GREASABLE PIN KIT (optional)	OMEGP9
HEADLAMP LEVELLING BRACKET	FK86

HISTORICAL REFERENCE - GVM UPGRADE - TOYOTA

(Catalogue 41 10/2019)

HILUX 2015 ON 4X4 ONLY - Not HiLux Rugged X AUSTRALIA ONLY

OE GVM	3000kg	FOR PRE REGISTERED VEHICLES ONLY
Upgraded GVM	*3465kg	SEATING CAPACITY: 2, 4, 5
ADR Approval Number	48108	<p>*SPECIAL REQUIREMENTS: Minimum of 600kg permanently carried load.</p> <p>NOTE: Warning Labels, part numbers 215727¹/38/28¹/39/29, supplied with compliance kits. For specific placement locations refer to PIB No's. 318 & 1017.</p>

VEHICLE VARIANTS - 4X4 ONLY

DESCRIPTION	BODY STYLE	ENGINE	TRANSMISSION	TYRE DESIGNATION	RIM SIZE
Double Cab	Utility	2.4/2.8 Diesel	Manual	265/65R17	17x7.5J
		4.0 Petrol	Automatic	265/60R18	18x7.5J
Double Cab	Cab Chassis	2.8 Diesel	Manual	265/65R17	17x7.5J
			Automatic		
Extra Cab	Utility	2.8 Diesel	Manual	265/65R17	17x7.5J
			Automatic		
Extra Cab	Cab Chassis	2.4/2.8 Diesel	Manual	265/65R17	17x7.5J
			Automatic		
Single Cab	Cab Chassis	2.4/2.8 Diesel	Manual Automatic	225/70R17C	17x6J

SUSPENSION SELECTION

DESCRIPTION	PART NUMBER
COMPLIANCE KIT 3465KG	HI3465

FRONT COILS	
NO ACCESSORIES	2869
BAR ONLY	2884
BAR & WINCH	2885
BAR, WINCH & ACCESSORIES	2887
FRONT STRUTS	90028 ¹
	90029 ¹
BP-51 COIL OVER RH	BP5190007R
BP-51 COIL OVER LH	BP5190007L
BP-51 FRONT FIT KIT	VM80010018
TRIM PACKER (optional)	OME95PF5

DESCRIPTION	PART NUMBER
REAR LEAF SPRINGS	
CONSTANT 600KG	EL091R ¹
EXTRA LEAF (if required)	EL45XL
REAR SHOCK	60133 ¹
BP-51 SHOCK RH	BP5160018R
BP-51 SHOCK LH	BP5160018L
BP-51 REAR FIT KIT	VM80010019
UBOLTS	OMEU53B
SPRING BUSH KIT	OMESB98
GREASABLE SHACKLE KIT (optional)	OMEGS25
HEADLAMP LEVELLING BRACKET	FK86

1. When remaining stock of 215727, 215728, 60133, 90028, 90029 and EL091R is exhausted no further product will be available.

HISTORICAL REFERENCE - GVM UPGRADE - TOYOTA

(Catalogue 41 10/2019)

HILUX 2015 ON 4X4 ONLY - Not HiLux Rugged X AUSTRALIA ONLY

OE GVM	3000kg	FOR PRE REGISTERED VEHICLES ONLY
Upgraded GVM	3150kg	SEATING CAPACITY: 2, 4, 5
ADR Approval Number	48108	

VEHICLE VARIANTS - 4X4 ONLY

DESCRIPTION	BODY STYLE	ENGINE	TRANSMISSION	TYRE DESIGNATION	RIM SIZE
Double Cab	Utility	2.4/2.8 Diesel	Manual	265/65R17	17x7.5J
		4.0 Petrol	Automatic	265/60R18	18x7.5J
Double Cab	Cab Chassis	2.8 Diesel	Manual	265/65R17	17x7.5J
			Automatic		
Extra Cab	Utility	2.8 Diesel	Manual	265/65R17	17x7.5J
			Automatic		
Extra Cab	Cab Chassis	2.4/2.8 Diesel	Manual	265/65R17	17x7.5J
			Automatic		
Single Cab	Cab Chassis	2.4/2.8 Diesel	Manual Automatic	225/70R17C	17x6J

SUSPENSION SELECTION

DESCRIPTION	PART NUMBER
COMPLIANCE KIT 3150KG	HI3150 ¹

FRONT COILS	
NO ACCESSORIES	2869
BAR ONLY	2884
BAR & WINCH	2885
BAR, WINCH & ACCESSORIES	2887
FRONT STRUTS	90028 ¹
	90029 ¹
BP-51 COIL OVER RH	BP5190007R
BP-51 COIL OVER LH	BP5190007L
BP-51 FRONT FIT KIT	VM80010018
TRIM PACKER (optional)	OME95PF5

DESCRIPTION	PART NUMBER
REAR LEAF SPRINGS	
CONSTANT 300KG	EL090R ¹
CONSTANT 600KG	EL091R ¹
EXTRA LEAF (if required)	EL45XL
REAR SHOCKS	60132 ¹
	60133 ¹
BP-51 SHOCK RH	BP5160018R
BP-51 SHOCK LH	BP5160018L
BP-51 REAR FIT KIT	VM80010019
UBOLTS	OMEU53A
	OMEU53B
SPRING BUSH KIT	OMESB98
GREASABLE SHACKLE KIT (optional)	OMEGS25
HEADLAMP LEVELLING BRACKET	FK86

1. When remaining stock of 60132, 60133, 90028, 90029, HI3150, EL090R and EL091R is exhausted no further product will be available.

HISTORICAL REFERENCE - GVM UPGRADE - TOYOTA

LANDCRUISER 200 SERIES

AUSTRALIA ONLY

OE GVM	3350kg	FOR PRE REGISTERED VEHICLES ONLY	
Upgraded GVM	3650kg	GX MODEL	
RVSA Approval Number	44363	SEATING CAPACITY: 5	
Compliance Kit Number	GX3650	*CAT6 INDICATORS* (REQUIRED)	*93214*

OE GVM	3350kg	FOR PRE REGISTERED VEHICLES ONLY	
Upgraded GVM	3650kg	GXL, VX, SAHARA MODELS	
RVSA Approval Number	40331	SEATING CAPACITY: 7,8	
Compliance Kit Number	2003650		

VEHICLE VARIANTS - GX Model

DESCRIPTION	BODY STYLE	ENGINE	TRANSMISSION	TYRE DESIGNATION	RIM SIZE
200 Series GX	Wagon	Diesel	Automatic	285/65R17	17x8J

VEHICLE VARIANTS - GXL, VX, SAHARA Models

DESCRIPTION	BODY STYLE	ENGINE	TRANSMISSION	TYRE DESIGNATION	RIM SIZE
200 Series GXL, VX, SAHARA	Wagon	Diesel	Automatic	285/65R17	17x8J
		Petrol		285/60R18	18x8J

SUSPENSION SELECTION

FRONT SELECTION	
DESCRIPTION	PART NUMBER
SPRINGS - 25mm	
NO ACCESSORIES	2700
BAR/ WINCH & ACC	2701
SPRINGS - 50mm	
NO ACCESSORIES	2702
BAR/ WINCH & ACC	2703
STRUTS	
NITROCHARGER SPORT	91005
BP-51	
BP-51 COIL OVER RH	BP5190003R
BP-51 COIL OVER LH	BP5190003L
BP-51 FRONT FIT KIT	VM80010003
FIT KITS & HARDWARE	
UPPER CONTROL ARM (optional)	UCA0001
TRIM PACKER (if required)	OME95PF5

REAR SELECTION		
DESCRIPTION		
LEAF SPRINGS		
CONSTANT 200kg	2723	
CONSTANT 400kg	2724	
CONSTANT 600kg	2725	
CONSTANT 200kg - KDSS	3186	
CONSTANT 400kg - KDSS	3187	
CONSTANT 600kg - KDSS	3188	
SHOCKS		
NITROCHARGER SPORT	61030	
BP-51		
BP-51 SHOCK	BP5160026	*BP5160053
BP-51 REAR FIT KIT	VM80010004	
BP-51 REAR FIT KIT KDSS	VM80010005	
FIT KITS & HARDWARE		
TRIM PACKERS (if required)	OME80PR05	
	OME80PR10	
STONE GUARD KIT (Nitrocharger Sport)	OME661	
HEAVY DUTY REAR SWAY BAR (recommended fit for NON KDSS Models)	OMESTAB5	

HISTORICAL REFERENCE - GVM UPGRADE - TOYOTA

LANDCRUISER 200 SERIES

AUSTRALIA ONLY

OE GVM	3350kg	FOR PRE REGISTERED VEHICLES ONLY	
Upgraded GVM	*4015kg	GX MODEL: SEATING CAPACITY 5	
RVSA Approval Number	44363	*CAT6 INDICATORS* (REQUIRED)	*93214*
Compliance Kit Number	GX4015	NOTE: Warning Labels, part numbers 215754/38/39 & 215971 ¹ , supplied with compliance kits.	

OE GVM	3350kg	FOR PRE REGISTERED VEHICLES ONLY	
Upgraded GVM	4015kg	GXL, VX, SAHARA MODELS	
RVSA Approval Number	40331	SEATING CAPACITY: 7,8	
Compliance Kit Number	2004015		

VEHICLE VARIANTS - GX Model

DESCRIPTION	BODY STYLE	ENGINE	TRANSMISSION	TYRE DESIGNATION	RIM SIZE
200 Series GX	Wagon	Diesel	Automatic	285/65R17	17x8J

VEHICLE VARIANTS - GXL, VX, SAHARA Models

DESCRIPTION	BODY STYLE	ENGINE	TRANSMISSION	TYRE DESIGNATION	RIM SIZE
200 Series GXL, VX, SAHARA	Wagon	Diesel	Automatic	285/65R17	17x8J
		Petrol		285/60R18	18x8J

Front Upgraded Axle Load: 1870kg

Rear Upgraded Axle Load: 2145kg

SUSPENSION SELECTION

FRONT SELECTION	
DESCRIPTION	PART NUMBER
SPRINGS - 25mm	
NO ACCESSORIES	2700
BAR/ WINCH & ACC	2701
SPRINGS - 50mm	
NO ACCESSORIES	2702
BAR/ WINCH & ACC	2703
STRUTS	
NITROCHARGER SPORT	91005 ¹
BP-51	
BP-51 COIL OVER RH	BP5190003R
BP-51 COIL OVER LH	BP5190003L
BP-51 FRONT FIT KIT	VM80010003
FIT KITS & HARDWARE	
UPPER CONTROL ARM (optional)	UCA0001
TRIM PACKER (if required)	OME95PF5

REAR SELECTION		
DESCRIPTION	PART NUMBER	
LEAF SPRINGS		
CONSTANT 400kg	2724	
CONSTANT 600kg	2725	
CONSTANT 400kg - KDSS	3187	
CONSTANT 600kg - KDSS	3188	
SHOCKS		
NITROCHARGER SPORT	61030 ¹	
BP-51		
BP-51 SHOCK RH	BP5160026	*BP5160053
BP-51 REAR FIT KIT	VM80010004	
BP-51 REAR FIT KIT KDSS	VM80010005	
FIT KITS & HARDWARE		
TRIM PACKERS (if required)	OME80PR05	
	OME80PR10	
STONE GUARD KIT (Nitrocharger Sport)	OME661	
HEAVY DUTY REAR SWAY BAR (recommended fit for NON KDSS Models)	OMESTAB5	

1. When remaining stock of 215971, 61030 and 91005 is exhausted no further product will be available.

HISTORICAL REFERENCE - GVM UPGRADE - TOYOTA

(Catalogue 42 12/2019)

LANDCRUISER 200 SERIES

AUSTRALIA ONLY

FOR PRE REGISTERED VEHICLES ONLY		
GX MODEL	GXL, VX, SAHARA MODELS	
SEATING CAPACITY: 5	SEATING CAPACITY: 7, 8	
OE GVM	3350kg	3350kg
Upgraded GVM	*3650kg **	*3650kg
ADR Approval Number	44363	40331

**Category 6 Side Indicators required ONLY for 3650kg GX model.

VEHICLE VARIANTS - GX Model

DESCRIPTION	BODY STYLE	ENGINE	TRANSMISSION	TYRE DESIGNATION	RIM SIZE
200 Series GX	Wagon	Diesel	Automatic	285/65R17	17x8J

VEHICLE VARIANTS - GXL, VX, SAHARA Models

DESCRIPTION	BODY STYLE	ENGINE	TRANSMISSION	TYRE DESIGNATION	RIM SIZE
200 Series GXL, VX, SAHARA	Wagon	Diesel	Automatic	285/65R17	17x8J
		Petrol		285/60R18	18x8J

SUSPENSION SELECTION

DESCRIPTION	PART NUMBER
COMPLIANCE KIT 3650KG - GX only	GX3650
COMPLIANCE KIT 3650KG - GXL/VX/SAHARA only	2003650
CATEGORY 6 SIDE INDICATORS - GX 3650kg Only	13.1051.000 ¹

FRONT COILS	
SPRINGS NO WEIGHT (25mm LIFT)	2700
SPRINGS NO WEIGHT (50mm LIFT)	2702
SPRINGS 100KG (25mm LIFT)	2701
SPRINGS 100KG (50mm LIFT)	2703
FRONT STRUT	91005 ¹
BP-51 COIL OVER RH	BP5190003R
BP-51 COIL OVER LH	BP5190003L
BP-51 FIT KIT	VM80010003
COIL PACKER (if required)	OME95PF5

DESCRIPTION	PART NUMBER
REAR COIL SPRINGS	
CONSTANT 200KG	2723
CONSTANT 400KG	2724
CONSTANT 600KG	2725
REAR SHOCK	61030 ¹
BP-51 REAR SHOCK	BP5160026
BP-51 FIT KIT	VM80010004
BP-51 FIT KIT KDSS REAR	VM80010005
TRIM PACKERS (if required)	OME80PR05
	OME80PR10
STONE GUARD KIT (Nitrocharger Sport)	OME661
HEAVY DUTY REAR SWAY BAR (recommended fit for NON KDSS Models)	OMESTAB5

1. When remaining stock of 61030, 91005 and 13.1051.000 is exhausted no further product will be available.

HISTORICAL REFERENCE - GVM UPGRADE - TOYOTA

(Catalogue 44 10/2020)

LANDCRUISER 200 SERIES

AUSTRALIA ONLY

FOR PRE REGISTERED VEHICLES ONLY		
GX MODEL	GXL, VX, SAHARA MODELS	
SEATING CAPACITY: 5	SEATING CAPACITY: 7, 8	
OE GVM	3350kg	3350kg
Upgraded GVM	4015kg **	4015kg
ADR Approval Number	44363	40331
*SPECIAL REQUIREMENTS:		
NOTE: Warning Labels supplied with compliance kits, part numbers as follows:		
215754 Axle Load Label	215738 In Vehicle Warning Label	
215739 Owners Manual Label	215971² Tyre Placard	
**Category 6 Side Indicators required ONLY for 4015kg GX model.		

VEHICLE VARIANTS - GX Model

DESCRIPTION	BODY STYLE	ENGINE	TRANSMISSION	TYRE DESIGNATION	RIM SIZE
200 Series GX	Wagon	V8 Diesel	Automatic	285/65R17	17x8J

VEHICLE VARIANTS - GXL, VX, SAHARA Models

DESCRIPTION	BODY STYLE	ENGINE	TRANSMISSION	TYRE DESIGNATION	RIM SIZE
200 Series GXL, VX, SAHARA	Wagon	Diesel	Automatic	285/65R17	17x8J
				285/60R18	18x8J

SUSPENSION SELECTION

DESCRIPTION	PART NUMBER
COMPLIANCE KIT 4015KG - GX only	GX4015
COMPLIANCE KIT 4015KG - GXL/VX/SAHARA only	2004015
CATEGORY 6 SIDE INDICATORS - GX 4015KG only	93214

FRONT COILS	
SPRINGS NO WEIGHT (25mm LIFT)	2700
SPRINGS NO WEIGHT (50mm LIFT)	2702
SPRINGS 100KG (25mm LIFT)	2701
SPRINGS 100KG (50mm LIFT)	2703
FRONT STRUT	91005 ²
BP-51 COIL OVER RH	BP5190003R
BP-51 COIL OVER LH	BP5190003L
BP-51 FIT KIT	VM80010003
¹ UPPER CONTROL ARM	UCA0001
COIL PACKER (if required)	OME95PF5

DESCRIPTION	PART NUMBER
REAR COIL SPRINGS	
CONSTANT 400KG	2724
CONSTANT 600KG	2725
REAR SHOCK	61030 ²
BP-51 REAR SHOCK	BP5160026
BP-51 FIT KIT	VM80010004
BP-51 FIT KIT KDSS REAR	VM80010005
TRIM PACKERS (if required)	OME80PR05
	OME80PR10
STONE GUARD KIT (recommended)	OME661
HEAVY DUTY REAR SWAY BAR (highly recommended fit for NON KDSS Models)	OMESTAB5

1. The OME Upper Control Arm will provide an increase between +2.5 and +3.5 degrees of caster and up to 1.5 degrees of negative camber increase (figures based off an approximate 50mm lift). Please note after fitment of Upper Control Arm a vehicle wheel alignment will be required.

2. When remaining stock of 215971, 61030 and 91005 is exhausted no further product will be available.

HISTORICAL REFERENCE - GVM UPGRADE - TOYOTA

(Catalogue 42 12/2019)

LANDCRUISER 200 SERIES

AUSTRALIA ONLY

FOR PRE REGISTERED VEHICLES ONLY		
GX MODEL		GXL, VX, SAHARA MODELS
SEATING CAPACITY: 5		SEATING CAPACITY: 7, 8
OE GVM	3350kg	3350kg
Upgraded GVM	3845kg **	3845kg
ADR Approval Number	44363	40331
*SPECIAL REQUIREMENTS: Minimum of 600kg permanently carried load. NOTE: Warning Labels, part numbers 215727 ¹ /38/28 ¹ /39/35, supplied with compliance kits. For specific placement locations refer to PIB No's. 608 & 1017.		*SPECIAL REQUIREMENTS: Minimum of 600kg permanently carried load. NOTE: Warning Labels, part numbers 215727 ¹ /38/28 ¹ /39/35, supplied with compliance kits. For specific placement locations refer to PIB No's. 608 & 1017.
**Category 6 Side Indicators required ONLY for 3845kg GX model.		

VEHICLE VARIANTS - GX Model

DESCRIPTION	BODY STYLE	ENGINE	TRANSMISSION	TYRE DESIGNATION	RIM SIZE
200 Series GX	Wagon	V8 Diesel	Automatic	285/65R17	17x8J

VEHICLE VARIANTS - GXL, VX, SAHARA Models

DESCRIPTION	BODY STYLE	ENGINE	TRANSMISSION	TYRE DESIGNATION	RIM SIZE
200 Series GXL, VX, SAHARA	Wagon	Diesel	Automatic	285/65R17	17x8J
		Petrol		285/60R18	18x8J

SUSPENSION SELECTION

DESCRIPTION	PART NUMBER
COMPLIANCE KIT 3845KG - GX only	GX3845 ¹
COMPLIANCE KIT 3845KG - GXL/VX/SAHARA only	2003845 ¹
CATEGORY 6 SIDE INDICATORS - GX 3845kg Only	13.1051.000 ¹

FRONT COILS	
SPRINGS NO WEIGHT (25mm LIFT)	2700
SPRINGS NO WEIGHT (50mm LIFT)	2702
SPRINGS 100KG (25mm LIFT)	2701
SPRINGS 100KG (50mm LIFT)	2703
FRONT STRUT	91005 ¹
BP-51 COIL OVER RH	BP5190003R
BP-51 COIL OVER LH	BP5190003L
BP-51 FIT KIT	VM80010003
COIL PACKER (if required)	OME95PF5

DESCRIPTION	PART NUMBER
REAR COIL SPRINGS	
CONSTANT 400KG	2724
CONSTANT 600KG	2725
REAR SHOCK	61030 ¹
BP-51 REAR SHOCK	BP5160026
BP-51 FIT KIT	VM80010004
BP-51 FIT KIT KDSS REAR	VM80010005
TRIM PACKERS (if required)	OME80PR05
	OME80PR10
STONE GUARD KIT (recommended)	OME661
HEAVY DUTY REAR SWAY BAR (recommended fit for NON KDSS Models)	OMESTAB5

1. When remaining stock of 13.1051.000, 2003845, 215727, 215728, 61030, 91005 and GX3845 is exhausted no further product will be available.

HISTORICAL REFERENCE - GVM UPGRADE - TOYOTA

(Catalogue 31 12/2015)

LANDCRUISER 200 SERIES

AUSTRALIA ONLY

GX MODEL		GXL, VX, SAHARA MODELS	
OE GVM	3300kg		3300kg
Upgraded GVM	3500kg 3580kg **		3580kg
ADR Approval Number	44136		40331

**Category 6 Side Indicators required ONLY for 3580kg GX model.

VEHICLE VARIANTS - GX Model

DESCRIPTION	BODY STYLE	ENGINE	TRANSMISSION	TYRE DESIGNATION	RIM SIZE
200 Series GX	Wagon	V8 Diesel	Automatic	285/65R17	17x8J

VEHICLE VARIANTS - GXL, VX, SAHARA Models

DESCRIPTION	BODY STYLE	ENGINE	TRANSMISSION	TYRE DESIGNATION	RIM SIZE
200 Series	Wagon	V8 Diesel	Automatic	285/65R17	17x8J
		V8 Petrol (4464)	Manual	285/60R18	18x8J
		V8 Petrol (4608)		285/65R17	17x8J

SUSPENSION SELECTION

DESCRIPTION	PART NUMBER
COMPLIANCE KIT 3500KG - GX only	GX3500 ¹
COMPLIANCE KIT 3580KG - GX only	GX3580 ¹
COMPLIANCE KIT 3580KG	2003580 ¹
CATEGORY 6 SIDE INDICATORS - GX 3580kg Only	13.1049.000 ¹

FRONT COILS	
SPRINGS 100KG (25mm LIFT)	2701
SPRINGS 100KG (50mm LIFT)	2703
FRONT STRUT	91005 ¹
BP-51 COIL-OVER	BP5190003L
	BP5190003R
BP-51 FIT KIT	VM80010003
COIL PACKER (if required)	OME95PF5

DESCRIPTION	PART NUMBER
REAR COIL SPRINGS	
CONSTANT 200KG	2723
CONSTANT 400KG	2724
CONSTANT 600KG	2725
REAR SHOCKS	61030 ¹
BP-51 REAR SHOCKS	BP5160003 ¹
BP-51 FIT KIT	VM80010004
BP-51 FIT KIT KDSS REAR	VM80010005
TRIM PACKER (if required)	OME80PR05
	OME80PR10
STONE GUARD KIT (recommended)	OME661

1. When remaining stock of 13.1049.000, 2003580, 61030, 91005, BP5160003, GX3500 and GX3580 is exhausted no further product will be available.

HISTORICAL REFERENCE - GVM UPGRADE - TOYOTA

(Catalogue 41 10/2019)

LANDCRUISER 70 SERIES DUAL CAB - 4 DOOR CAB CHASSIS AUSTRALIA ONLY

OE GVM	3300kg	FOR PRE REGISTERED VEHICLES ONLY
Upgraded GVM	*3950kg **	SEATING CAPACITY: 5
ADR Approval Number	12446	*SPECIAL REQUIREMENTS: Minimum of 600kg permanently carried load.
**Category 6 Side Indicators required.		NOTE: Warning Labels, part numbers 215727 ¹ /38/28 ¹ /39/3/4 ¹ /4A, supplied with compliance kits. For specific placement locations refer to PIB No's. 422 & 1017.

VEHICLE VARIANTS - DUAL CAB 4 DOOR CAB CHASSIS

DESCRIPTION	BODY STYLE	ENGINE	TRANSMISSION	TYRE DESIGNATION	RIM SIZE
70 Series Dual Cab	Cab Chassis	4.5 Turbo Diesel	Manual	225/95R16	16x6J
				265/70R16	16x7JJ

SUSPENSION SELECTION

DESCRIPTION	PART NUMBER
70 SERIES COMPLIANCE KIT	703950
CATEGORY 6 SIDE INDICATORS	13.1051.000 ¹

FRONT COILS	
NO ACCESSORIES / BAR ONLY	2856
BAR AND WINCH	2859
FRONT SHOCK	60008 ¹
BP-51 SHOCK	BP5160009 ¹
BP-51 FIT KIT	VM80010006
STEERING DAMPER (optional)	OMESD47
CASTER KIT (if required)	OMECA77B
SWAY BAR SPACER KIT (if required)	FK19

DESCRIPTION	PART NUMBER
REAR LEAF SPRINGS	
CONSTANT 600/500KG	EL081R ¹
CONSTANT 800/700KG	EL082R ¹
EXTRA LEAF (if required)	EL14XL
REAR SHOCKS	60011 ¹
	60109 ¹
BP-51 REAR SHOCK SUITS ¹ EL081R	BP5160028
BP-51 REAR SHOCK SUITS ¹ EL082R	BP5160029 ¹
BP-51 FIT KIT	VM80010007
U BOLT	OMEU59B
	OMEU59C
SPRING BUSH KIT	OMESB101
GREASABLE SHACKLE KIT (optional)	OMEGS10
GREASABLE SHACKLE FIXED END PIN KIT (optional)	OMEGP7
GREASABLE SHACKLE BUSH KIT (optional)	OMESB85
HEAVY DUTY REAR SWAY BAR (mandatory)	OMESTAB9
SWAY BAR FIT KITS (mandatory)	FK76
	FK77

1. When remaining stock of 13.1051.000, 215727, 215728, 215734, 60008, 60011, 60109, BP5160009, BP5160029, EL081R and EL082R is exhausted no further product will be available.

HISTORICAL REFERENCE - GVM UPGRADE - TOYOTA

(Catalogue 28.2 05/2013)

LANDCRUISER 70 SERIES DUAL CAB - 4 DOOR CAB CHASSIS AUSTRALIA ONLY

OE GVM **3300kg** **SEATING CAPACITY: 5**

Upgraded GVM **3780kg**

ADR Approval Number **12446**

**Category 6 Side Indicators required.

VEHICLE VARIANTS

DESCRIPTION	BODY STYLE	ENGINE	TRANSMISSION	TYRE DESIGNATION	RIM SIZE
70 Series Dual Cab	Cab Chassis	4.5 Turbo Diesel	Manual	7.5R 16 8PR 265/70R16LT	16x5.50F 16x7JJ

SUSPENSION SELECTION

DESCRIPTION	PART NUMBER
70 SERIES COMPLIANCE KIT	703780
CATEGORY 6 SIDE INDICATORS	13.1049.000 ¹

FRONT COILS	
0 TO 50KG	2859
51 TO 120KG	2853
FRONT SHOCKS	60008 ¹
STEERING DAMPER (optional)	OMESD47
CASTER KIT (if required)	OMECA77B
SWAY BAR SPACER KIT (if required)	FK19
ABS WIRE BRACKET KIT	FK65

DESCRIPTION	PART NUMBER
REAR LEAF SPRINGS	
CONSTANT 300KG	CS014R ¹ / EL014R ¹
CONSTANT 500KG	CS015R ¹ / EL015R ¹
CONSTANT 700KG	CS066R ¹ / EL066R ¹
EXTRA LEAF (if required)	D14XL / EL14XL
REAR SHOCKS	60011 ¹
	60109 ¹
U BOLT	OMEU59B
SPRING BUSH KIT	OMESB101
GREASABLE SHACKLE KIT (optional)	OMEGS10
GREASABLE FIXED END KIT (optional)	OMEGP7
GREASABLE SHACKLE BUSH KIT (optional)	OMESB85
HEAVY DUTY REAR SWAY BAR (optional)	OMESTAB2 ¹
SWAY BAR FIT KIT (optional)	FK44
	FK45
BRAKE PROPORTIONING BRACKET	FK51
	FK58
CENTER BOLT	UCB17 /
	UCB4

1. When remaining stock of 13.1049.000, 60008, 60011, 60109, CS014R, CS015R, CS066R, EL014R, EL015R, EL066R, EL080R, EL081R, EL082R and OMESTAB2 is exhausted no further product will be available.

HISTORICAL REFERENCE - GVM UPGRADE - TOYOTA

(Catalogue 33 01/2017)

LANDCRUISER 76 SERIES

AUSTRALIA ONLY

OE GVM 3060kg FOR PRE REGISTERED VEHICLES ONLY

Upgraded GVM 3660kg SEATING CAPACITY: 5

ADR Approval Number 12446

**Category 6 Side Indicators required.

VEHICLE VARIANTS

DESCRIPTION	BODY STYLE	ENGINE	TRANSMISSION	TYRE DESIGNATION	RIM SIZE
76 Series	4 Door Wagon	4.5 Turbo Diesel	Manual	7.5R 16 8PR 265/70R16LT 225/95R 16C	16x5.50F 16x7JJ 16x6J

SUSPENSION SELECTION

DESCRIPTION	PART NUMBER
76 SERIES COMPLIANCE KIT	763600 ¹
CATEGORY 6 SIDE INDICATORS	13.1051.000 ¹

FRONT COILS	
0 TO 60KG	2856
61 TO 120KG	2859
FRONT SHOCKS	60008 ¹
BP-51 FRONT SHOCK	BP5160009 ¹
BP-51 KIT FRONT LC76	VM80010006
STEERING DAMPER (optional)	OMESD47
CASTER KIT (if required)	OMECA77B
SWAY BAR SPACER KIT (if required)	FK19
ABS WIRE BRACKET KIT (if required)	FK88 ¹

DESCRIPTION	PART NUMBER
REAR LEAF SPRINGS	
CONSTANT 400KG	CS058R
CONSTANT 800KG	CS070R
EXTRA LEAF (if required)	D35XL
REAR SHOCKS	60011 ¹ 60111 ¹
BP-51 REAR SHOCK	BP5160028
BP-51 SHOCK REAR LONG 682	BP5160029 ¹
BP-51 KIT REAR LC76	VM80010007
U BOLT	OMEU59D
SPRING BUSH KIT	OMESB86
GREASABLE SHACKLE KIT (optional)	OMEGS19
GREASABLE FIXED END KIT (optional)	OMEGP7
GREASABLE SHACKLE BUSH KIT (optional)	OMESB85
HEAVY DUTY REAR SWAY BAR (optional)	OMESTAB9
SWAY BAR FIT KIT (optional)	FK76 FK77
CENTRE BOLT	UCB17

1. When remaining stock of 13.1051.000, 60008, 60011, 60111, 763600, BP5160009, BP5160029 and FK88 is exhausted no further product will be available.

HISTORICAL REFERENCE - GVM UPGRADE - TOYOTA

(Catalogue 29.1 04/2015)

LANDCRUISER 76 SERIES

AUSTRALIA ONLY

OE GVM **3000kg** **SEATING CAPACITY: 5**

Upgraded GVM **3600kg**

ADR Approval Number **12446**

**Category 6 Side Indicators required.

VEHICLE VARIANTS

DESCRIPTION	BODY STYLE	ENGINE	TRANSMISSION	TYRE DESIGNATION	RIM SIZE
76 Series	4 Door Wagon	4.5 Turbo Diesel	Manual	7.5R 16 8PR 265/70R16LT	16x5.50F 16x7JJ

SUSPENSION SELECTION

DESCRIPTION	PART NUMBER
76 SERIES COMPLIANCE KIT	763600 ¹
CATEGORY 6 SIDE INDICATORS	13.1049.000 ¹

FRONT COILS	
0 TO 60KG	2856
61 TO 120KG	2859
FRONT SHOCKS	60008 ¹
STEERING DAMPER (optional)	OMESD47
CASTER KIT (if required)	OMECA77B
SWAY BAR SPACER KIT (if required)	FK19
ABS WIRE BRACKET KIT	FK65

DESCRIPTION	PART NUMBER
REAR LEAF SPRINGS	
CONSTANT 400KG	CS058R
CONSTANT 800KG	CS070R
EXTRA LEAF (if required)	D35XL
REAR SHOCKS	60011 ¹
	60111 ¹
U BOLT	OMEU59D
SPRING BUSH KIT	OMESB86
GREASABLE SHACKLE KIT (optional)	OMEGS19
GREASABLE FIXED END KIT (optional)	OMEGP7
GREASABLE SHACKLE BUSH KIT (optional)	OMESB85
HEAVY DUTY REAR SWAY BAR (optional)	OMESTAB2 ¹
SWAY BAR FIT KIT (optional)	FK44
	FK45
BRAKE PROPORTIONING BRACKET	FK51
	FK58
CENTRE BOLT	UCB17

1. When remaining stock of 13.1049.000, 60008, 60011, 60111, 763600 and OMESTAB2 is exhausted no further product will be available.

HISTORICAL REFERENCE - GVM UPGRADE - TOYOTA

(Catalogue 28.2 05/2013)

LANDCRUISER 78 SERIES

AUSTRALIA ONLY

OE GVM	3300kg	*SEATING CAPACITY: 3, 5
		*NOTE: 11 seater not allowed.
Upgraded GVM	3780kg	
ADR Approval Number	12446	

**Category 6 Side Indicators required.

VEHICLE VARIANTS

DESCRIPTION	BODY STYLE	ENGINE	TRANSMISSION	TYRE DESIGNATION	RIM SIZE
78 Series	2 Door Wagon	4.5 Turbo Diesel	Manual	7.5R 16 8PR	16x5.50F

SUSPENSION SELECTION

DESCRIPTION	PART NUMBER
78 SERIES COMPLIANCE KIT	783700
CATEGORY 6 SIDE INDICATORS	13.1049.000 ¹

FRONT COILS	
0 TO 50KG	2859
51 TO 120KG	2853
FRONT SHOCKS	60008 ¹
STEERING DAMPER (optional)	OMESD47
CASTER KIT (if required)	OMECA77B
SWAY BAR SPACER KIT (if required)	FK19
ABS WIRE BRACKET KIT	FK65

DESCRIPTION	PART NUMBER
REAR LEAF SPRINGS	
CONSTANT 400KG	CS014R ¹ / EL014R ¹
CONSTANT 600KG	CS015R ² / EL015R ¹
CONSTANT 800KG	CS066R ¹ / EL066R ¹
EXTRA LEAF (if required)	D14XL / EL14XL
REAR SHOCKS	60011 ¹ 60109 ¹
U BOLT	OMEU59B
SPRING BUSH KIT	OMESB86
SWAY BAR BRACKET KIT	FK34
GREASABLE SHACKLE KIT (optional)	OMEGS19
GREASABLE FIXED END KIT (optional)	OMEGP7
GREASABLE SHACKLE BUSH KIT (optional)	OMESB85
HEAVY DUTY REAR SWAY BAR (optional)	OMESTAB2 ¹
SWAY BAR FIT KIT (optional)	FK44 FK45
BRAKE PROPORTIONING BRACKET	FK51 FK58
CENTRE BOLT	UCB17 / UCB4

1. When remaining stock of 13.1049.000, 60008, 60011, 60109, CS014R, CS015R, CS066R, EL014R, EL015R, EL066R, EL080R, EL081R, EL082R and OMESTAB2 is exhausted no further product will be available.

HISTORICAL REFERENCE - GVM UPGRADE - TOYOTA

(Catalogue 41 10/2019)

LANDCRUISER 79 SERIES - SINGLE CAB - 2 DOOR CAB CHASSIS AUSTRALIA ONLY

OE GVM	3400kg	FOR PRE REGISTERED VEHICLES ONLY
Upgraded GVM	*3950kg **	SEATING CAPACITY: 2, 3
ADR Approval Number	12446	*SPECIAL REQUIREMENTS: Minimum of 600kg permanently carried load.
**Category 6 Side Indicators required.		NOTE: Warning Labels, part numbers 215727 ¹ /38/28 ¹ /39/3/4 ¹ /4A, supplied with compliance kits. For specific placement locations refer to PIB No's. 422 & 1017.

VEHICLE VARIANTS - 2 DOOR CAB CHASSIS

DESCRIPTION	BODY STYLE	ENGINE	TRANSMISSION	TYRE DESIGNATION	RIM SIZE
79 Series Single Cab	Cab Chassis	4.5 Turbo Diesel	Manual	225/95R16 265/70R16	16x6J 16x7JJ

SUSPENSION SELECTION

DESCRIPTION	PART NUMBER
79 SERIES COMPLIANCE KIT	793950
CATEGORY 6 SIDE INDICATORS	13.1051.000 ¹

FRONT COILS	
NO ACCESSORIES / BAR ONLY	2856
BAR AND WINCH	2859
FRONT SHOCK	60008 ¹
BP-51 SHOCK	BP5160009 ¹
BP-51 FIT KIT	VM80010006
STEERING DAMPER (optional)	OMESD47
CASTER KIT (if required)	OMECA77B
SWAY BAR SPACER KIT (if required)	FK19

DESCRIPTION	PART NUMBER
REAR LEAF SPRINGS	
CONSTANT 600/500KG	EL081R ¹
CONSTANT 800/700KG	EL082R ¹
EXTRA LEAF (if required)	EL14XL
REAR SHOCKS	60011 ¹ 60109 ¹
BP-51 LC79 REAR SHOCK	BP5160028
BP-51 REAR SHOCK SUITS ¹ EL082R	BP5160029 ¹
BP-51 KIT LC79 REAR	VM80010007
U BOLTS	OMEU59B OMEU59C
SPRING BUSH KIT	OMESB101
GREASABLE SHACKLE KIT (optional)	OMEGS10
GREASABLE SHACKLE FIXED END PIN KIT (optional)	OMEGP7
GREASABLE SHACKLE BUSH KIT (optional)	OMESB85
HEAVY DUTY REAR SWAY BAR (mandatory)	OMESTAB9
SWAY BAR FIT KITS (mandatory)	FK76 FK77

1. When remaining stock of 13.1051.000, 215727, 215728, 215734, 60008, 60011, 60109, BP5160009, BP5160029, EL081R and EL082R is exhausted no further product will be available.

HISTORICAL REFERENCE - GVM UPGRADE - TOYOTA

(Catalogue 28.2 05/2013)

LANDCRUISER 79 SERIES - SINGLE CAB - 2 DOOR CAB CHASSIS AUSTRALIA ONLY

OE GVM	3300kg	SEATING CAPACITY: 2, 3
Upgraded GVM	3780kg	
ADR Approval Number	12446	

**Category 6 Side Indicators required.

VEHICLE VARIANTS

DESCRIPTION	BODY STYLE	ENGINE	TRANSMISSION	TYRE DESIGNATION	RIM SIZE
79 Series	Cab Chassis	4.5 Turbo Diesel	Manual	7.5R 16 8PR 265/70R16LT	16x5.50F 16x7JJ

SUSPENSION SELECTION

DESCRIPTION	PART NUMBER
79 SERIES COMPLIANCE KIT	793700
CATEGORY 6 SIDE INDICATORS	13.1049.000 ¹

FRONT COILS	
0 TO 50KG	2859
51 TO 120KG	2853
FRONT SHOCKS	60008 ¹
STEERING DAMPER (optional)	OMESD47
CASTER KIT (if required)	OMECA77B
SWAY BAR SPACER KIT (if required)	FK19
ABS WIRE BRACKET KIT	FK65

DESCRIPTION	PART NUMBER
REAR LEAF SPRINGS	
CONSTANT 400KG	CS014R ¹ / EL014R ¹
CONSTANT 600KG	CS015R ¹ / EL015R ¹
CONSTANT 800KG	CS066R ¹ / EL066R ¹
EXTRA LEAF (if required)	D14XL / EL14XL
REAR SHOCKS	60011 ¹ 60109 ¹
U BOLT	OMEU59B
SPRING BUSH KIT	OMESB101
GREASABLE SHACKLE KIT (optional)	OMEGS10
GREASABLE FIXED END KIT (optional)	OMEGP7
GREASABLE SHACKLE BUSH KIT (optional)	OMESB85
HEAVY DUTY REAR SWAY BAR (optional)	OMESTAB2 ¹
SWAY BAR FIT KIT (optional)	FK44 FK45
BRAKE PROPORTIONING BRACKET	FK51 FK58
CENTRE BOLT	UCB17 / UCB4

1. When remaining stock of 13.1049.000, 60008, 60011, 60109, CS014R, CS015R, CS066R, EL014R, EL015R, EL066R, EL080R, EL081R, EL082R and OMESTAB2 is exhausted no further product will be available.

GVM UPGRADE - TOYOTA

(Catalogue 52 April 2023)

LANDCRUISER 70 SERIES DUAL CAB - 4 DOOR CAB CHASSIS

AUSTRALIA ONLY

OE GVM	3300kg	FOR PRE REGISTERED VEHICLES ONLY			
Upgraded GVM	3950kg	SEATING CAPACITY: 5			
RVSA Approval Number	VTA-012446	*SPECIAL REQUIREMENTS*			
Compliance Kit Number	703950	Minimum of 600kg permanently carried load at all times.			
		NOTE: Warning Labels, part numbers 215738/39/3/4 ¹ or 4A, supplied with compliance kits. For specific placement locations refer to PIB No's. 422 & 1017.			
Category 6 Side Indicators are required			P/N: *93214*		
Axle Loads	Front OE	1480kg	Front Upgraded	1540kg	
	Rear OE	2300kg	Rear Upgraded	2410kg	
VEHICLE VARIANTS - DUAL CAB 4 DOOR CAB CHASSIS					
DESCRIPTION	BODY STYLE	ENGINE	TRANSMISSION	TYRE DESIGNATION	RIM SIZE
70 Series Dual Cab	Cab Chassis	4.5 Turbo Diesel	Manual	225/95R16 265/70R16	16x6J 16x7JJ

SUSPENSION SELECTION

FRONT SELECTION	
DESCRIPTION	PART NUMBER
SPRINGS	
NO ACC or BAR ONLY	2856
BAR/ WINCH & ACC	2859
STRUTS	
NITROCHARGER SPORT	60008
NITROCHARGER PLUS	63008
BP-51	
BP-51 SHOCK FRONT	BP5160042
BP-51 FRONT FIT KIT	VM80010006
FIT KITS & HARDWARE	
STEERING DAMPER (optional)	OMESD47
CASTER KIT (if required)	OMECA77B
SWAY BAR SPACER KIT (if required)	FK19

REAR SELECTION	
DESCRIPTION	PART NUMBER
LEAF SPRINGS	
CONSTANT 500/600kg	EL115R
CONSTANT 700/800kg	EL116R
EXTRA LEAF (if required)	EL14XL
SHOCKS	
NITROCHARGER SPORT	*60109 / 60011
NITROCHARGER PLUS	*63109 / 63011
BP-51	
BP-51 SHOCK REAR SUITS EL115R	BP5160028
BP-51 SHOCK REAR SUITS EL116R	BP5160052
BP-51 REAR FIT KIT	VM80010007
FIT KITS & HARDWARE	
U BOLTS	OMEU59B OMEU59C
SPRING BUSH KIT	OMESB101
GREASABLE BUSH KIT (optional)	OMESB85
GREASABLE SHACKLE KIT (optional)	OMEGS10
GREASABLE SHACKLE END PIN KIT (optional)	OMEGP7
HEAVY DUTY REAR SWAY BAR (MANDATORY)	OMESTAB9
SWAY BAR FIT KIT (MANDATORY)	FK76 FK77

NOTE: There is a choice of front and rear springs depending on the set up of the particular vehicle. Please read comments relating to fitment of components. For all information refer to the vehicle specific selection page.

GVM UPGRADE - TOYOTA

(Catalogue 52 April 2023)

LANDCRUISER 70 SERIES DUAL CAB - 4 DOOR CAB CHASSIS AUSTRALIA ONLY

OE GVM		3300kg	FOR PRE REGISTERED VEHICLES ONLY		
Upgraded GVM		3780kg	SEATING CAPACITY: 5		
RVSA Approval Number		VTA-012446	*CAT6 INDICATORS* (REQUIRED)		P/N: *93214*
Compliance Kit Number		703780			
Axle Loads	Front OE	1480kg	Front Upgraded	1480kg	
	Rear OE	2300kg	Rear Upgraded	2300kg	
VEHICLE VARIANTS - DUAL CAB 4 DOOR CAB CHASSIS					
DESCRIPTION	BODY STYLE	ENGINE	TRANSMISSION	TYRE DESIGNATION	RIM SIZE
70 Series Dual Cab	Cab Chassis	4.5 Turbo Diesel	Manual	7.5R 16 8PR	16x5.50F
				265/70R16LT	16x7JJ
				225/95R 16C	16x6J

SUSPENSION SELECTION

FRONT SELECTION	
DESCRIPTION	PART NUMBER
SPRINGS	
NO ACC or BAR ONLY	2856
BAR/ WINCH	2859
BAR/ WINCH & ACC	2853
STRUTS	
NITROCHARGER SPORT	60008
NITROCHARGER PLUS	63008
BP-51	
BP-51 SHOCK FRONT	BP5160042
BP-51 FRONT FIT KIT	VM80010006
FIT KITS & HARDWARE	
STEERING DAMPER (optional)	OMESD47
CASTER KIT (if required)	OMECA77B
SWAY BAR SPACER KIT (if required)	FK19

REAR SELECTION	
DESCRIPTION	PART NUMBER
LEAF SPRINGS	
CONSTANT 300kg	EL114R
CONSTANT 500kg	EL115R
CONSTANT 700kg	EL116R
EXTRA LEAF (if required)	EL14XL
SHOCKS	
NITROCHARGER SPORT	*60109 / 60011
NITROCHARGER PLUS	*63109 / 63011
BP-51	
BP-51 SHOCK REAR SUITS EL114R/ EL115R	BP5160028
BP-51 SHOCK REAR SUITS EL116R	BP5160052
BP-51 REAR FIT KIT	VM80010007
FIT KITS & HARDWARE	
U BOLTS	OMEU59B
	OMEU59C
SPRING BUSH KIT	OMESB101
GREASABLE BUSH KIT (optional)	OMESB85
GREASABLE SHACKLE KIT (optional)	OMEGS10
GREASABLE SHACKLE END PIN KIT (optional)	OMEGP7
HEAVY DUTY REAR SWAY BAR (optional)	OMESTAB9
SWAY BAR FIT KIT (optional)	FK76
	FK77

NOTE: There is a choice of front and rear springs depending on the set up of the particular vehicle. Please read comments relating to fitment of components. For all information refer to the vehicle specific selection page.

GVM UPGRADE - TOYOTA

(Catalogue 52 April 2023)

LANDCRUISER 76 SERIES

AUSTRALIA ONLY

OE GVM		3060kg	FOR PRE REGISTERED VEHICLES ONLY		
Upgraded GVM		3660kg	SEATING CAPACITY: 5		
RVSA Approval Number		VTA-012446	*CAT6 INDICATORS* (REQUIRED)		P/N: *93214*
Compliance Kit Number		763660			
Axle Loads	Front OE	1480kg	Front Upgraded	1480kg	
	Rear OE	2300kg	Rear Upgraded	2300kg	
VEHICLE VARIANTS					
DESCRIPTION	BODY STYLE	ENGINE	TRANSMISSION	TYRE DESIGNATION	RIM SIZE
76 Series	4 Door Wagon	4.5 Turbo Diesel	Manual	7.5R 16 8PR	16x5.50F
				265/70R16LT	16x7JJ
				225/95R 16C	16x6J

SUSPENSION SELECTION

FRONT SELECTION	
DESCRIPTION	PART NUMBER
SPRINGS	
NO ACC or BAR ONLY	2856
BAR/ WINCH & ACC	2859
SHOCKS	
NITROCHARGER SPORT	60008
NITROCHARGER PLUS	63008
BP-51	
BP-51 SHOCK FRONT	BP5160042
BP-51 FRONT FIT KIT	VM80010006
FIT KITS & HARDWARE	
STEERING DAMPER (optional)	OMESD47
CASTER KIT (if required)	OMECA77B
SWAY BAR SPACER KIT (if required)	FK19

REAR SELECTION	
DESCRIPTION	PART NUMBER
LEAF SPRINGS	
CONSTANT 400kg	CS058R
CONSTANT 800kg	CS070R
EXTRA LEAF (if required) does not suit CS070R	D35XL
SHOCKS	
NITROCHARGER SPORT	*60011 / 60111
NITROCHARGER PLUS	*63011 / 63111
BP-51	
BP-51 SHOCK REAR SUITS CS058R	BP5160028
BP-51 SHOCK REAR SUITS CS070R	BP5160052
BP-51 REAR FIT KIT	VM80010007
FIT KITS & HARDWARE	
U BOLTS	OMEU59D
	OMEU59B
SPRING BUSH KIT	OMESB86
GREASABLE BUSH KIT (optional)	OMESB85
GREASABLE SHACKLE KIT (optional)	OMEGS19
GREASABLE SHACKLE END PIN KIT (optional)	OMEGP7
CENTRE BOLT (if required)	UCB17

NOTE: There is a choice of front and rear springs depending on the set up of the particular vehicle. Please read comments relating to fitment of components. For all information refer to the vehicle specific selection page.

GVM UPGRADE - TOYOTA

(Catalogue 52 April 2023)

LANDCRUISER 78 SERIES

AUSTRALIA ONLY

OE GVM		3300kg	FOR PRE REGISTERED VEHICLES ONLY		
Upgraded GVM		3780kg	SEATING CAPACITY: 2,5 (NOT 11 SEATER)		
RVSA Approval Number		VTA-012446	*CAT6 INDICATORS* (REQUIRED)		P/N: *93214*
Compliance Kit Number		783700			
Axle Loads	Front OE	1480kg	Front Upgraded	1480kg	
	Rear OE	2300kg	Rear Upgraded	2300kg	
VEHICLE VARIANTS					
DESCRIPTION	BODY STYLE	ENGINE	TRANSMISSION	TYRE DESIGNATION	RIM SIZE
78 Series	2 Door Wagon	4.5 Turbo Diesel	Manual	7.5R 16 8PR 225/95R 16C	16x5.50F 16x6J

SUSPENSION SELECTION

FRONT SELECTION	
DESCRIPTION	PART NUMBER
SPRINGS	
NO ACC or BAR ONLY	2856
BAR/ WINCH	2859
BAR/ WINCH & ACC	2853
SHOCKS	
NITROCHARGER SPORT	60008
NITROCHARGER PLUS	63008
BP-51	
BP-51 SHOCK FRONT	BP5160042
BP-51 FRONT FIT KIT	VM80010006
FIT KITS & HARDWARE	
STEERING DAMPER (optional)	OMESD47
CASTER KIT (if required)	OMECA77B
SWAY BAR SPACER KIT (if required)	FK19

REAR SELECTION	
DESCRIPTION	PART NUMBER
LEAF SPRINGS	
CONSTANT 400kg	EL114R
CONSTANT 600kg	EL115R
CONSTANT 800kg	EL116R
EXTRA LEAF (if required)	EL14XL
SHOCKS	
NITROCHARGER SPORT	*60109 / 60011
NITROCHARGER PLUS	*63109 / 63011
BP-51	
BP-51 SHOCK REAR SUITS EL114R/ EL115R	BP5160028
BP-51 SHOCK REAR SUITS EL116R	BP5160052
BP-51 REAR FIT KIT	VM80010007
FIT KITS & HARDWARE	
U BOLTS	OMEU59B
	OMEU59C
SPRING BUSH KIT	OMESB86
GREASABLE BUSH KIT (optional)	OMESB85
GREASABLE SHACKLE KIT (optional)	OMEGS19
GREASABLE SHACKLE END PIN KIT (optional)	OMEGP7
HEAVY DUTY REAR SWAY BAR (MANDATORY)	OMESTAB9
SWAY BAR FIT KIT (MANDATORY)	FK76
	FK77
SWAY BAR BRACKET KIT	FK34

NOTE: There is a choice of front and rear springs depending on the set up of the particular vehicle. Please read comments relating to fitment of components. For all information refer to the vehicle specific selection page.

GVM UPGRADE - TOYOTA

(Catalogue 52 April 2023)

LANDCRUISER 79 SERIES - SINGLE CAB - 2 DOOR CAB CHASSIS AUSTRALIA ONLY

OE GVM	3400kg	FOR PRE REGISTERED VEHICLES ONLY			
Upgraded GVM	3950kg	SEATING CAPACITY: 2, 3			
RVSA Approval Number	VTA-012446	*SPECIAL REQUIREMENTS* Minimum of 600kg permanently carried load at all times.			
Compliance Kit Number	793950	NOTE: Warning Labels, part numbers 215738/39/3/4 ¹ or 4A, supplied with compliance kits. For specific placement locations refer to PIB No's. 422 & 1017.			
Category 6 Side Indicators are required			P/N: *93214*		
Axle Loads	Front OE	1480kg	Front Upgraded	1540kg	
	Rear OE	2300kg	Rear Upgraded	2410kg	
VEHICLE VARIANTS - 2 DOOR CAB CHASSIS					
DESCRIPTION	BODY STYLE	ENGINE	TRANSMISSION	TYRE DESIGNATION	RIM SIZE
79 Series Single Cab	Cab Chassis	4.5 Turbo Diesel	Manual	225/95R16 265/70R16	16x6J 16x7JJ

SUSPENSION SELECTION

FRONT SELECTION	
DESCRIPTION	PART NUMBER
SPRINGS	
NO ACC or BAR ONLY	2856
BAR/ WINCH & ACC	2859
SHOCKS	
NITROCHARGER SPORT	60008
NITROCHARGER PLUS	63008
BP-51	
BP-51 SHOCK FRONT	BP5160042
BP-51 FRONT FIT KIT	VM80010006
FIT KITS & HARDWARE	
STEERING DAMPER (optional)	OMESD47
CASTER KIT (if required)	OMECA77B
SWAY BAR SPACER KIT (if required)	FK19

REAR SELECTION	
DESCRIPTION	PART NUMBER
LEAF SPRINGS	
CONSTANT 500/600kg	EL115R
CONSTANT 700/800kg	EL116R
EXTRA LEAF (if required)	EL14XL
SHOCKS	
NITROCHARGER SPORT	*60109 / 60011
NITROCHARGER PLUS	*63109 / 63011
BP-51	
BP-51 SHOCK REAR SUITS EL114R/ EL115R	BP5160028
BP-51 SHOCK REAR SUITS EL116R	BP5160052
BP-51 REAR FIT KIT	VM80010007
FIT KITS & HARDWARE	
U BOLTS	OMEU59B OMEU59C
SPRING BUSH KIT	OMESB101
GREASABLE BUSH KIT (optional)	OMESB85
GREASABLE SHACKLE KIT (optional)	OMEGS10
GREASABLE SHACKLE END PIN KIT (optional)	OMEGP7
HEAVY DUTY REAR SWAY BAR (MANDATORY)	OMESTAB9
SWAY BAR FIT KIT (MANDATORY)	FK76 FK77

NOTE: There is a choice of front and rear springs depending on the set up of the particular vehicle. Please read comments relating to fitment of components. For all information refer to the vehicle specific selection page.

GVM UPGRADE - TOYOTA

(Catalogue 52 April 2023)

LANDCRUISER 79 SERIES - SINGLE CAB - 2 DOOR CAB CHASSIS AUSTRALIA ONLY

OE GVM		3400kg	FOR PRE REGISTERED VEHICLES ONLY		
Upgraded GVM		3780kg	SEATING CAPACITY: 2, 3		
RVSA Approval Number		VTA-012446	*CAT6 INDICATORS* (REQUIRED)		P/N: *93214*
Compliance Kit Number		793700			
Axle Loads	Front OE	1480kg	Front Upgraded	1480kg	
	Rear OE	2300kg	Rear Upgraded	2300kg	
VEHICLE VARIANTS - 2 DOOR CAB CHASSIS					
DESCRIPTION	BODY STYLE	ENGINE	TRANSMISSION	TYRE DESIGNATION	RIM SIZE
79 Series	Cab Chassis	4.5 Turbo Diesel	Manual	7.5R 16 8PR 265/70R16LT 225/95R 16C	16x5.50F 16x7JJ 16x6J

SUSPENSION SELECTION

FRONT SELECTION	
DESCRIPTION	PART NUMBER
SPRINGS	
NO ACC or BAR ONLY	2856
BAR/ WINCH	2859
BAR/ WINCH & ACC	2853
SHOCKS	
NITROCHARGER SPORT	60008
NITROCHARGER PLUS	63008
BP-51	
BP-51 SHOCK FRONT	BP5160042
BP-51 FRONT FIT KIT	VM80010006
FIT KITS & HARDWARE	
STEERING DAMPER (optional)	OMESD47
CASTER KIT (if required)	OMECA77B
SWAY BAR SPACER KIT (if required)	FK19

REAR SELECTION	
DESCRIPTION	PART NUMBER
LEAF SPRINGS	
CONSTANT 400kg	EL114R
CONSTANT 600kg	EL115R
CONSTANT 800kg	EL116R
EXTRA LEAF (if required)	EL14XL
SHOCKS	
NITROCHARGER SPORT	*60109 / 60011
NITROCHARGER PLUS	*63109 / 63011
BP-51	
BP-51 SHOCK REAR SUITS EL114R/ EL115R	BP5160028
BP-51 SHOCK REAR SUITS EL116R	BP5160052
BP-51 REAR FIT KIT	VM80010007
FIT KITS & HARDWARE	
U BOLTS	OMEU59B
	OMEU59C
SPRING BUSH KIT	OMESB101
GREASABLE BUSH KIT (optional)	OMESB85
GREASABLE SHACKLE KIT (optional)	OMEGS10
GREASABLE SHACKLE END PIN KIT (optional)	OMEGP7
HEAVY DUTY REAR SWAY BAR (optional)	OMESTAB9
SWAY BAR FIT KIT (optional)	FK76
	FK77

NOTE: There is a choice of front and rear springs depending on the set up of the particular vehicle. Please read comments relating to fitment of components. For all information refer to the vehicle specific selection page.

FRONT SELECTION

ALL MODELS		Part Number	Qty	Notes
FRONT ARMoured	Spring	2701	1	
	Strut - N/Sport	90024	2	3

FIT KITS & HARDWARE

Loc	Description	Part Number	Qty	Note
F	FRONT SWAY BAR	OMESTAB4	1	
F	STRUT TOP HAT KIT	OMETH003		1
F	TRIM PACKER	OME95PF5	EA	

REAR SELECTION

ALL MODELS		Part Number	Qty	Note
REAR ARMoured	Spring	3067	1	
	Shock - N/Sport	60119	2	3

FIT KITS & HARDWARE

Loc	Description	Part Number	Qty	Note
R	REAR SWAY BAR	OMESTAB6		
R	REAR SWAY BAR FIT KIT	FK75	1	
R	STONE GUARD KIT	OME661		2
R	TRIM PACKER	OME80PR10	EA	

NOTES ON ARMoured SUSPENSION SELECTION & FITMENT:

The above suspension systems have been designed and tested to suit a vehicle weight range of 3.9 - 4.5T, for vehicle weights outside this range please contact ARB.

Components have been designed to operate as a complete replacement system, it is not recommended to fit these products individually.

OME661 Lower Shock Stone Guards are recommended fitment for protection against stone damage on

All fitting kits, components and replacement bushes are included with the above products where

Comments

1 Strut Top Hat Kit may be required if original equipment is worn.

2 OME661 lower shock stone gaurds are recommended fitment for protection against stone damage.

3 LC200 Armoured Suspension System was designed for and tested on non-KDSS equipped vehicles.

FRONT SELECTION

ALL MODELS		Part Number	Qty	Notes
FRONT ARMoured	Spring	2978	1	
	Strut - N/Sport	90025	2	1

FIT KITS & HARDWARE

Loc	Description	Part Number	Qty	Note
F	FRONT SWAY BAR	OMESTAB7	1	

REAR SELECTION

ALL MODELS		Part Number	Qty	Note
REAR ARMoured	Spring	3069	1	2
	Shock - N/Sport	60120	2	1

FIT KITS & HARDWARE

Loc	Description	Part Number	Qty	Note
R	REAR SWAY BAR	OMESTAB8	1	

NOTES ON ARMoured SUSPENSION SELECTION & FITMENT:

The above suspension systems have been designed and tested to suit a vehicle weight range of 3.9 - 4.5T, for vehicle weights outside this range please contact ARB.

Components have been designed to operate as a complete replacement system, it is not recommended to fit these products individually.

All fitting kits, components and replacement bushes are included with the above products where

Comments

1 Y62 Armoured Suspension System was designed for and tested on non-HBMC equipped vehicles.

2 When remaining stock of 3069 is exhausted no further product will be available.

FRONT SELECTION

V6 PETROL ENGINE		Part Number	Qty	Notes
Estimated Lift 40mm	No Bar	Spring	3118	
		Strut - N/Sport L	90035	1
		Strut - N/Sport R	90036	1
	Bar Only	Spring	3119	
		Strut - N/Sport L	90035	1
		Strut - N/Sport R	90036	1
	Bar/ Winch/ Accessories	Spring	3120	
		Strut - N/Sport L	90035	1
		Strut - N/Sport R	90036	1
	Nitro +	Spring	4029	
		Strut - N/Plus L	93035	1
		Strut - N/Plus R	93036	1,3

V8 & 3.2L DIESEL ENGINE		Part Number	Qty	Note
Estimated Lift 40mm	No Bar	Spring	3119	
		Strut - N/Sport L	90035	1
		Strut - N/Sport R	90036	1
	Bar Only	Spring	3120	
		Strut - N/Sport L	90035	1
		Strut - N/Sport R	90036	1
	Bar/ Winch/ Accessories	Spring	3121	
		Strut - N/Sport L	90035	1
		Strut - N/Sport R	90036	1
	Nitro +	Spring	4030	
		Strut - N/Plus L	93035	1
		Strut - N/Plus R	93036	1,3

Comments

1 No top mounting bushes and dirt shield supplied, re-use OE bushes and dirt shield. Original struts and OME coils cannot be used together.

2 Tow Pack option uses Nivomat (self-levelling) shock absorber and requires a specific design. **Please note:** when replacing Nivomat shocks, you **must** fit the OME spring.

To identify whether a vehicle has the standard fitment rear shock or Nivomat shock, the outer body diameter will need to be measured.

Standard: 51mm

Nivomat: 63mm

3 Does not suit OE Coil

Fitting Time: Due to the complexity of installation allow 4 hours for complete install.

FIT KITS & HARDWARE

Loc	Description	Part Number	Qty	Note
F	TRIM PACKER	FK79	EA	

REAR SELECTION

ALL MODELS (EXCL TOW PACK)		Part Number	Qty	Notes
Est Lift 40mm	Medium Load	Spring	3074	1
		Shock - N/Sport	60124	2
		Shock - N/Plus	63124	1
	Constant 200kg	Spring	3060	1
		Shock - N/Sport	60125	2
		Shock - N/Plus	63125	1

Comments

1 No top mounting bushes and dirt shield supplied, re-use OE bushes and dirt shield. Original struts and OME coils cannot be used together.

2 Tow Pack option uses Nivomat (self-levelling) shock absorber and requires a specific design.

Please note: when replacing Nivomat shocks, you **must** fit the OME spring.

REAR SELECTION MID 2017 ON

TOW PACK (95mm pin)		Part Number	Qty	Notes
Est Lift 40mm	Medium Load	Spring	3074	1
		Shock - N/Sport	60152	2
		Shock - N/Plus	63152	1,2
	Constant 200kg	Spring	3060	1
		Shock - N/Sport	60153	2
		Shock - N/Plus	63153	1,2

To identify whether a vehicle has the standard fitment rear shock or Nivomat shock, the outer body diameter will need to be measured.

Standard: 51mm

Nivomat: 63mm

3 Does not suit OE Coil

REAR SELECTION 2016 TO 2017

TOW PACK (75mm pin)		Part Number	Qty	Notes
Est Lift 40mm	Medium Load	Spring	3074	1
		Shock - N/Sport	60126	2
		Shock - N/Plus	63126	1,2
	Constant 200kg	Spring	3060	1
		Shock - N/Sport	60127	2
		Shock - N/Plus	63127	1,2

Fitting Time: Due to the complexity of installation allow 4 hours for complete install.

FRONT SELECTION

V6 PETROL ENGINE			Part Number	Qty	Notes
Estimated Lift 40mm	No Bar	Spring	3118	1	
		Strut - N/Sport	90026	2	1
	Bar Only	Spring	3119	1	
		Strut - N/Sport	90026	2	1
	Bar/ Winch/ Accessories	Spring	3120	1	
		Strut - N/Sport	90026	2	1
	Nitro +	Spring	4029	1	
		Strut - N/Plus	93026	2	1,3

Comments

1 No top mounting bushes and dirt shield supplied, re-use OE bushes and dirt shield. Original struts and OME coils cannot be used together.

2 Tow Pack option uses Nivomat (self-levelling) shock absorber and requires a specific design. **Please note:** when replacing Nivomat shocks, you **must** fit the OME spring.

To identify whether a vehicle has the standard fitment rear shock or Nivomat shock, the outer body diameter will need to be measured.

Standard: 51mm

Nivomat: 63mm

3 Does not suit OE Coil

Fitting Time: Due to the complexity of installation allow 4 hours for complete install.

V8 & 3.2L DIESEL ENGINE			Part Number	Qty	Note
Est Lift 40mm	No Bar	Spring	3119	1	
		Strut - N/Sport	90026	2	1
	Bar Only	Spring	3120	1	
		Strut - N/Sport	90026	2	1
	Bar/ Winch/ Accessories	Spring	3121	1	
		Strut - N/Sport	90026	2	1
	Nitro +	Spring	4030	1	
		Strut - N/Plus	93026	2	1,3

FIT KITS & HARDWARE

Loc	Description	Part Number	Qty	Note
F	TRIM PACKER	FK79	EA	

REAR SELECTION

ALL MODELS (EXCL TOW PACK)			Part Number	Qty	Notes
Est Lift 40mm	Medium Load	Spring	3074	1	
		Shock - N/Sport	60124	2	1
		Shock - N/Plus	63124		
	Constant 200kg	Spring	3060	1	
		Shock - N/Sport	60125	2	1
		Shock - N/Plus	63125		

TOW PACK (95mm pin)			Part Number	Qty	Notes
Est Lift 40mm	Medium Load	Spring	3074	1	2
		Shock - N/Sport	60152	2	1,2
		Shock - N/Plus	63152		
	Constant 200kg	Spring	3060	1	2
		Shock - N/Sport	60153	2	1,2
		Shock - N/Plus	63153		

TOW PACK (75mm pin)			Part Number	Qty	Notes
Est Lift 40mm	Medium Load	Spring	3074	1	2
		Shock - N/Sport	60126	2	1,2
		Shock - N/Plus	63126		
	Constant 200kg	Spring	3060	1	2
		Shock - N/Sport	60127	2	1,2
		Shock - N/Plus	63127		

FRONT SELECTION

V8 PETROL & DIESEL ENGINES		Part Number	Qty	Notes
Est Lift 50mm	No Bar	Spring	2990	1
		Strut - N/Sport	*N219S / N188S	2 1
	Bar Only	Spring	2991	1
		Strut - N/Sport	*N219S / N188S	2 1
	Bar/ Winch/ Accessories	Spring	2991	1
		Strut - N/Sport	*N219S / N188S	2

Comments

- 1 No top mounting bushes supplied, re-use OE bushes.

REAR SELECTION

ALL MODELS		Part Number	Qty	Note
Est Lift 55mm	Medium Load	Spring	2992	1
		Shock - N/Sport	*N220 / N190	2 1
	Heavy Load	Spring	2993	1
		Shock - N/Sport	*N220 / N190	2 1

FRONT SELECTION

V6 & V8 PETROL ENGINES		Part Number	Qty	Notes	
Est Lift 40mm	No Bar	Spring	2935	1	
		Shock - N/Sport	60087	2	
	Bar Only	Spring	2936	1	2
		Shock - N/Sport	60087	2	
	Bar/ Winch/ Accessories	Spring	2936	1	
		Strut - N/Sport	60087	2	

Comments

- 1 OMESTAB1 is a lighter rate OME replacement stabiliser bar which is a recommended fitment so maximum ride quality improvement can be obtained. (OMESTAB1 does not suit 2.7 Diesel Models).
- 2 Add 1 only OMEWJPF10 Trim Packer to increase ride height for vehicles with bull bar and winch.
- 3 When remaining stock of N117 is exhausted no further product will be available.

FRONT SELECTION

DIESEL ENGINES		Part Number	Qty	Notes	
Est Lift 40mm	No Bar	Spring	2936	1	2
		Shock - N/Sport	60087	2	
	Bar Only	Spring	2936	1	2
		Shock - N/Sport	60087	2	
	Bar/ Winch/ Accessories	Spring	2936	1	
		Strut - N/Sport	60087	2	

FIT KITS & HARDWARE

Loc	Description	Part Number	Qty	Note
F	STABILISER BAR	OMESTAB1	1	1
F	TRIM PACKER	OMEWJPF10	EA	2

REAR SELECTION

ALL MODELS		Part Number	Qty	Note	
Est Lift 40mm	Medium Load	Spring	2944	1	
		Shock - N/Sport	60088	2	3
	Heavy Load	Spring	2945	1	
		Shock - N/Sport	60088	2	3

FIT KITS & HARDWARE

Loc	Description	Part Number	Qty	Note
R	TRIM PACKER	OMEWTJPR10	EA	

FRONT SELECTION

6 CYLINDER ENGINES			Part Number	Qty	Notes
Est Lift 20-25mm	No Bar	Spring	2931	1	
		Shock - N/Sport	60092	2	2
	Bar Only	Spring	2930	1	
		Shock - N/Sport	60092	2	2
	Bar/ Winch/ Accessories	Spring	2930	1	
		Shock - N/Sport	60092	2	2

Comments

- 1 OMESD40 will only fit left hand drive models.
- 2 When remaining stock of N39 is exhausted no further product will be available.

FRONT SELECTION

V8 ENGINES			Part Number	Qty	Notes
20-25mm	No Bar & Bar Only	Spring	2934	1	
		Shock - N/Sport	60092	2	2
	Bar/ Winch/ Accessories	Spring	2934	1	
		Shock - N/Sport	60092	2	2

FIT KITS & HARDWARE

Loc	Description	Part Number	Qty	Note
F	STEERING DAMPER	OMESD40	1	1
F	COIL PACKER	OMEJGF10	EA	

REAR SELECTION

ALL MODELS			Part Number	Qty	Note
20-25mm	Medium Load	Spring	2940	1	
		Shock - N/Sport	60093	2	
	Constant 100kg	Spring	2943	1	
		Shock - N/Sport	60093	2	

FIT KITS & HARDWARE

Loc	Description	Part Number	Qty	Note
R	COIL PACKER	OMEJGR10	EA	

FRONT SELECTION

V8 PETROL & DIESEL ENGINES		Part Number	Qty	Notes
Est Lift 50mm	No Bar	Spring	2990	1
		Strut - N/Charger	*N219S / N188S	2 1
	Bar Only	Spring	2991	1
		Strut - N/Charger	*N219S / N188S	2 1
	Bar/ Winch/ Accessories	Spring	2991	1
		Strut - N/Sport	*N219S / N188S	2

Comments

- * Heavier valved shock
- 1** No top mounting bushes supplied, re-use OE bushes.

REAR SELECTION

ALL MODELS		Part Number	Qty	Note
Est Lift 55mm	Light Load	Spring	2992	1
		Shock - N/Charger	*N220 / N190	2 1
	Medium Load	Spring	2993	1
		Shock - N/Charger	*N220 / N190	2 1

FRONT SELECTION

DIESEL ENGINE		Part Number	Qty	Notes
Est Lift 35-45mm	No Bar	Spring	2930	1
		Shock - N/Sport	60052	2
	Bar Only	Spring	2930	1
		Shock - N/Sport	60052	2
	Bar/ Winch/ Accessories	Spring	2930	1
		Shock - N/Sport	60052	2

FIT KITS & HARDWARE

Loc	Description	Part Number	Qty	Note
F	STEERING DAMPER	OMESD40	1	5
F	TRIM PACKER	OMEJGF10	EA	3

REAR SELECTION

DIESEL ENGINE		Part Number	Qty	Note	
Est Lift 50mm	Light Load	Leaf Spring	CS034RA / B	1+1	
		Shock - N/Sport	60053	2	
	Medium Load	Leaf Spring	CS035RA / B	1+1	
		Shock - N/Sport	60053	2	
	U-BOLTS		OMEU60	4	1
			OMEU57		
EXTRA LEAF		D22XL	2		

FIT KITS & HARDWARE

Loc	Description	Part Number	Qty	Note
R	GEARBOX PACKER KIT	XJGK01	EA	4
R	CENTRE BOLT		2	6
R	SPRING BUSH KIT	OE		

WARNING:

XJ Models fitted with a 3 bolt engine exhaust pipe flange, can experience a clearance problem with the tail shaft when suspension is under full deflection. Fitment of an adjustable front panhard rod or a change to a smaller 2 bolt flange will provide the required clearance.

Comments

1 OMEU60 suits Dana 35 type differential - Australian Models. OMEU57 suits AMC 8 1/4 type differential.

2 Trimming requirement greater than 10mm use A/A fitment. Where near level rake is desired B/B fitment should be used. D22XL extra leaf can be fitted to CS034RA/B and CS035RA/B for heavier constant load carrying ability.

NB: Models fitted with OE Up Country Suspension pack will only be raised by 20mm.

3 OMEJGF10 front coil packer can be used for trimming or extra lift purposes, using no more than 1 packer.

4 Fit XJGK01 Gearbox Packer Kit should a driveline vibration occur.

5 OMESD40 will only fit left hand drive models.

6 Refer to **Leaf Spring Service Parts** section for Centre Bolt selection.

FRONT SELECTION

V6 3.7L PETROL ENGINE		Part Number	Qty	Notes	
Est Lift 30-40mm	No Bar	Spring	2926	1	1
		Strut - N/Sport	90009	2	2
	Bar Only	Spring	2927	1	1
		Strut - N/Sport	90009	2	2
	Bar/ Winch/ Accessories	Spring	2927	1	1
		Strut - N/Sport	90009	2	2
	Nitro +	Spring	2925	1	1
		Strut - N/Plus	93009	2	2,3

Comments

- 1 Due to varying OE ride heights, some KK Models may only achieve a 20mm lift.
- 2 No top mounting bushes supplied, re-use OE bushes.
- 3 Does not suit OE Coil

FRONT SELECTION

2.8 CRD DIESEL ENGINE		Part Number	Qty	Notes	
Est Lift 30-40mm	No Bar	Spring	2927	1	1
		Strut - N/Sport	90009	2	2
	Bar Only	Spring	2790	1	1
		Strut - N/Sport	90009	2	2
	Bar/ Winch/ Accessories	Spring	2790	1	1
		Strut - N/Sport	90009	2	2
	Bar/ Winch/ Accessories	Spring	2926	1	1
		Strut - N/Plus	93009	2	2, 3

REAR SELECTION

ALL MODELS		Part Number	Qty	Note	
Est Lift 40mm	Medium Load	Spring	2730	1	1
		Shock - N/Sport	60069	2	2, 3
		Shock - N/Plus	63069		
	Constant 100kg	Spring	2731	1	1
		Shock - N/Sport	60069	2	2, 3
		Shock - N/Plus	63069		

FRONT SELECTION

PETROL ENGINE			Part Number	Qty	Notes
Estimated Lift 30-40mm	No Bar	Spring	2925	1	1
		Strut - N/Charger	NS130	2	2,3
		Strut - N/Sport	90009		2
	Bar Only	Spring	2926	1	1
		Strut - N/Sport	90009	2	2
	Bar/ Winch/ Accessories	Spring	2927	1	1
		Strut - N/Sport	90009	2	2
	Nitro +	Spring	2925	1	1
		Strut - N/Plus	93009	2	2,4

Comments

- 1 Due to varying OE ride heights, some KJ models may only achieve a 20mm lift.
- 2 No top mounting bushes supplied, re-use OE bushes.
- 3 When remaining stock of NS130 / NS131 / N132 is exhausted no further product will be available.
- 4 Does not suit OE Coil

FRONT SELECTION

DIESEL ENGINE			Part Number	Qty	Notes
Estimated Lift 30-40mm	No Bar	Spring	2926	1	1
		Strut - N/Charger	NS130	2	2,3
		Strut - N/Sport	90009		2
	Bar Only	Spring	2927	1	1
		Strut - N/Sport	90009	2	2
	Bar/ Winch/ Accessories	Spring	2790	1	1
		Strut - N/Sport	90009	2	2
	Nitro +	Spring	2926	1	1
		Strut - N/Plus	93009		2,4

REAR SELECTION

ALL MODELS			Part Number	Qty	Note
Est Lift 40mm	Light Load	Spring	2947	1	
		Shock - N/Charger	N132	2	3
		Shock - N/Sport	60069		
	Shock - N/Plus	63069			
	Medium Load	Spring	2948	1	
		Shock - N/Charger	N132	2	3
		Shock - N/Sport	60069		
	Shock - N/Plus	63069			

FRONT SELECTION

6 CYLINDER ENGINE		Part Number	Qty	Notes	
Estimated Lift 50mm	No Bar	Spring	2932	1	1
		Shock - N/Sport	*60047 / 60046	2	6, 7
		Shock - N/Plus	*63047 / 63046		
	Bar Only	Spring	2933	1	1
		Shock - N/Sport	*60047 / 60046	2	6, 7
		Shock - N/Plus	*63047 / 63046		
	Bar/ Winch/ Accessories	Spring	2933	1	1
		Shock - N/Sport	*60047 / 60046	2	6, 7
		Shock - N/Plus	*63047 / 63046		

Comments

* Heavier valved option

1 For ride height and trim adjustment use - Front: OMEJGF10 / Rear: OMEWTJPR10

2 FKWTJ01 Panhard Rod Extension Bracket Kit fitment to right hand drive or FKWTJ02 to left hand drive models is **mandatory** to ensure correct rear axle tracking.

3 A Gear Box Packer Kit is **mandatory** fitment to prevent driveline vibration.

JWVGK01 suits all models to 2003.

JWVGK02 suits manual models from 2003.

JWVGK03 suits auto models from 2003.

4 FK16: **Mandatory** fitment 20mm Bump Stop Spacer Kit to prevent coil springs becoming solid on full compression.

5 OMESD40 only suitable for fitment to left hand drive models.

6 To achieve optimal vehicle balance front to rear when rear spring 2949 is fitted, it is recommended that only 60047 is fitted to the front.

7 When existing stock of N66, N66C, 60046, 60047 and 60049 is exhausted no further product will be available.

FIT KITS & HARDWARE

Loc	Description	Part Number	Qty	Note
F	TRIM PACKER	OMEJGF10	EA	
F	STEERING DAMPER	OMESD40	1	5

REAR SELECTION

2 DOOR		Part Number	Qty	Notes	
Estimated Lift 50mm	Medium Load	Spring	2941	1	1
		Shock - N/Sport	60048	2	
		Shock - N/Plus	63048		
	Constant 100kg	Spring	2942	1	1
		Shock - N/Sport	60048	2	
		Shock - N/Plus	63048		
	Constant 200kg	Spring	2949	1	6
		Shock - N/Sport	60049	2	7
		Shock - N/Plus	63049		

REAR SELECTION

UNLIMITED		Part Number	Qty	Notes	
Est Lift 50mm	Medium Load	Spring	2949	1	6
		Shock - N/Sport	60049	2	7
		Shock - N/Plus	63049		
	Constant 200kg	Spring	2996	1	
		Shock - N/Sport	60049	2	7
		Shock - N/Plus	63049		

FIT KITS & HARDWARE

Loc	Description	Part Number	Qty	Notes
R	TRIM PACKER	OMEWTJPR10	EA	
R	PANHARD ROD BRK KIT	FKWTJ01	1	2
		FKWTJ02		
R	GEARBOX PACKER KIT	JWVGK01	1	3
		JWVGK02		
		JWVGK03		
R	BUMPER STOP SPACER KIT	FK16	1	4

FRONT SELECTION

PETROL ENGINE		Part Number	Qty	Notes	
Estimated Lift 40-50mm	No Bar	Leaf Spring	CS014F	2	4
		Shock - N/Sport	60098		
	Bar Only	Leaf Spring	CS014F	2	4
		Shock - N/Sport	60098		
	Bar/ Winch/ Accessories	Leaf Spring	CS014F	2	4
		Shock - N/Sport	60098		
	SPRING BUSH KIT		OMESB57	2	2
			OMESB87		
	GREASABLE PIN KIT		OMEGP9	1	2
	GREASABLE SHACKLE KIT		OMEGS11		
EXTRA LEAF		D23XL	2		

Comments

- 1 JWGK01 fitment reduces driveline vibration
- 2 Use OMESB57 with original shackles. OMESB87 with OMEGS11 greasable shackles.
- 3 OMESD40 will only fit left hand drive models.
- 4 Please re-use original U-Bolts.

CS037R - suits Soft Top, light load.
CS036R - suits Hard Top medium load to 200kgs.
- 5 Refer to **Leaf Spring Service Parts** section for Centre Bolt selection.

FIT KITS & HARDWARE

Loc	Description	Part Number	Qty	Note
F	GEARBOX PACKER KIT	JWGK01	1	1
F	STEERING DAMPER	OMESD40		3
F/R	CENTRE BOLT		2	5

REAR SELECTION

ALL MODELS		Part Number	Qty	Note	
Estimated Lift 50mm	Light Load	Leaf Spring	CS037R	1	4
		Shock - N/Sport	60099	2	
	Medium Load	Leaf Spring	CS036R	1	4
		Shock - N/Sport	60099	2	
	SPRING BUSH KIT		OMESB57	2	2
			OMESB87		
	GREASABLE PIN KIT		OMEGP9	1	2
	GREASABLE SHACKLE KIT		OMEGS11		
	EXTRA LEAF		D24XL	2	

FIT KITS & HARDWARE

Loc	Description	Part Number	Qty	Note
F/R	CENTRE BOLT		2	5

FRONT SELECTION

3.6L PETROL ENGINE			Part Number	Qty	Notes
Estimated Lift 50mm	No Bar	Spring	3160	1	1
		Shock - N/Sport	60160	2	
		Shock - N/Plus	63160		
	Bar Only	Spring	3160	1	1
		Shock - N/Sport	*60162 / 60160	2	
		Shock - N/Plus	*63162 / 63160		
	Bar/ Winch/ Accessories	Spring	3153	1	
		Shock - N/Sport	60162	2	
		Shock - N/Plus	63162		

Comments

- 1 Use OMEJKPF10 to achieve lift with bar only. Do not fit more than one (1) packer per coil spring.
- 2 Fitment of LCAJLFR Front Lower Control Arm is **recommended** to restore wheel alignment castor settings. LCAJLFR should be set at 5mm longer than OE prior to wheel alignment.
- 3 Fitment of FK100 is **mandatory**. FK100 Bump Stop Kit prevents springs from going solid.
- 4 For trim adjustment use - Front: OMEJKPF10 Rear: OMEJLPR10. Do not fit more than one (1) packer per coil spring.

FIT KITS & HARDWARE

Loc	Description	Part Number	Qty	Note
F	LOWER CONTROL ARM - ADJUST	LCAJLFR	1	2
F	TRIM PACKER	OMEJKPF10	EA	4

REAR SELECTION

3.6L PETROL ENGINE			Part Number	Qty	Note
Est Lift 50mm	Medium Load	Spring	3161	1	
		Shock - N/Sport	60161	2	
		Shock - N/Plus	63161		
	Constant 150kg	Spring	3157	1	
		Shock - N/Sport	*60162 / 60161	2	
		Shock - N/Plus	*63162 / 63161		

FIT KITS & HARDWARE

Loc	Description	Part Number	Qty	Note
F	BUMP STOP KIT	FK100	1	3
R	TRIM PACKER	OMEJLPR10	EA	4

FRONT SELECTION

Estimated Lift: Sport - 3.5" (90mm) / Rubicon - 2.5" (65mm)

PETROL ENGINE		Part Number	Qty	Notes
No Bar	Spring	3133	1	1
	Shock - N/Sport	60150	2	3
	Shock - N/Plus	63150		
Bar Only	Spring	3134	1	1
	Shock - N/Sport	60150	2	3
	Shock - N/Plus	63150		
Bar/ Winch/ Accessories	Spring	3134	1	1
	Shock - N/Sport	60150	2	3
	Shock - N/Plus	63150		
BP-51	Shock	BP5160033	2	
	Fit Kit	VM80010038	1	

Lift increase is approximate and will depend on vehicle weights.

Modifications for off road use only.

The products listed in this selection chart are deemed by Old Man Emu to be suitable for off road use and their legality for public road use should be certified by the relevant Registration Authority. An Off Road Use Only Disclaimer must be signed by the customer.

Modifications and replacement of other associated components will be required.

FIT KITS & HARDWARE

Loc	Description	Part Number	Qty	Note
F	LOWER CONTROL ARM - ADJUST	LCAJLFR		2
F	BUMP STOP KIT	FK92		3
F	SWAY BAR LINK KIT	FK105	1	
F	UPPER CONTROL ARM - ADJUST	UCAJLFR		4
F	PANHARD ROD ADJUSTABLE (LHD)	PANR JL001		
F	TRIM PACKER	OMEJKPF10	EA	1

Comments

1 For trim adjustment use - Front: OMEJKPF10
Rear: OMEJLPR10. Do not fit more than one (1) packer per coil spring.

2 Fitment of LCAJLFR Front Lower Control Arm is **required** to restore wheel alignment castor settings.

3 Fitment of FK92 is **mandatory**. FK92 Bump Stop Kit prevents shock absorbers from going solid for fitment of larger tyres. Fitment of FK105 is **mandatory**. FK105 allows the shocks to extend freely without limit or contact.

4 Fitment **not mandatory**, however fitment will allow for fine tuning vehicle geometry.

5 Not suitable for models with headlight adjustment, no provision for adjustment link.

REAR SELECTION

Estimated Lift: Sport - 3.5" (90mm) / Rubicon - 2.5" (65mm)

SWB MODELS		Part Number	Qty	Note
Medium Load	Spring	3136	1	1
	Shock - N/Sport	60151	2	2
	Shock - N/Plus	63151		
Constant 150kg	Spring	3137	1	1
	Shock - N/Sport	60151	2	2
	Shock - N/Plus	63151		
BP-51	Shock RH	BP5160034R		
	Shock LH	BP5160034L	1	
	Fit Kit	VM80010039		

FIT KITS & HARDWARE

Loc	Description	Part Number	Qty	Note
R	LOWER CONTROL ARM - ADJUST	LCAJKRR		4
R	UPPER CONTROL ARM - ADJUST	UCAJKRR	1	4,5
R	PANHARD ROD ADJUSTABLE (LHD)	PANR JL002		4
R	TRIM PACKER	OMEJLPR10	EA	1

FRONT SELECTION

3.6L PETROL ENGINE			Part Number	Qty	Notes
Estimated Lift 50mm	No Bar	Spring	3153	1	
		Shock - N/Sport	60160	2	
		Shock - N/Plus	63160		
	Bar Only	Spring	3153	1	1
		Shock - N/Sport	*60162 / 60160	2	
		Shock - N/Plus	*63162 / 63160		
	Bar/ Winch/ Accessories	Spring	3154	1	
		Shock - N/Sport	60162	2	
		Shock - N/Plus	63162		

Comments

- 1 Use OMEJKPF10 to achieve lift with bar only. Do not fit more than one (1) packer per coil spring.
- 2 Fitment of LCAJLFR Front Lower Control Arm is recommended to restore wheel alignment castor settings. LCAJLFR should be set at 5mm longer than OE prior to wheel alignment.
- 3 Fitment of FK100 is mandatory. FK100 Bump Stop Kit prevents springs from going solid.
- 4 For trim adjustment use - Front: OMEJKPF10 Rear: OMEJLPR10. Do not fit more than one (1) packer per coil spring.

2.2L DIESEL ENGINE			Part Number	Qty	Note
Estimated Lift 50mm	No Bar	Spring	3155	1	
		Shock - N/Sport	60160	2	
		Shock - N/Plus	63160		
	Bar Only	Spring	3155	1	1
		Shock - N/Sport	*60162 / 60160	2	
		Shock - N/Plus	*63162 / 63160		
	Bar/ Winch/ Accessories	Spring	3156	1	
		Shock - N/Sport	60162	2	
		Shock - N/Plus	63162		

FIT KITS & HARDWARE

Loc	Description	Part Number	Qty	Note
F	LOWER CONTROL ARM ADJUST	LCAJLFR	1	2
F	TRIM PACKER	OMEJKPF10	EA	4

REAR SELECTION

3.6L PETROL ENGINE			Part Number	Qty	Notes
Estimated Lift 50mm	Medium Load	Spring	3157	1	
		Shock - N/Sport	60161	2	
		Shock - N/Plus	63161		
	Constant 150kg	Spring	3158	1	
		Shock - N/Sport	*60163 / 60161	2	
		Shock - N/Plus	*63163 / 63161		
	Constant 300kg	Spring	3159	1	
		Shock - N/Sport	60163	2	
		Shock - N/Plus	63163		

2.2L DIESEL ENGINE			Part Number	Qty	Notes
Estimated Lift 50mm	Medium Load	Spring	3137	1	
		Shock - N/Sport	60161	2	
		Shock - N/Plus	63161		
	Constant 150kg	Spring	3138	1	
		Shock - N/Sport	*60163 / 60161	2	
		Shock - N/Plus	*63163 / 63161		
	Constant 300kg	Spring	3139	1	
		Shock - N/Sport	60163	2	
		Shock - N/Plus	63163		

FIT KITS & HARDWARE

Loc	Description	Part Number	Qty	Notes
R	BUMP STOP KIT	FK100	1	3
R	TRM PACKER	OMEJLPR10	EA	4

FRONT SELECTION

Estimated Lift: Sport - 3.5" (90mm) / Rubicon - 2.5" (65mm)

PETROL ENGINE		Part Number	Qty	Notes
No Bar	Spring	3134	1	1
	Shock - N/Sport	60150	2	3
	Shock - N/Plus	63150		
Bar Only	Spring	3135	1	1
	Shock - N/Sport	60150	2	3
	Shock - N/Plus	63150		
Bar/ Winch/ Accessories	Spring	3135	1	1
	Strut - N/Sport	60150	2	3
	Strut - N/Plus	63150		
BP-51	Shock	BP5160033	2	
	Fit Kit	VM80010038	1	

DIESEL ENGINE		Part Number	Qty	Notes
No Bar	Spring	3175	1	1
	Shock - N/Sport	60150	2	3
	Shock - N/Plus	63150		
Bar Only	Spring	3162	1	1
	Shock - N/Sport	60150	2	3
	Shock - N/Plus	63150		
Bar/ Winch/ Accessories	Spring	3162	1	1
	Shock - N/Sport	60150	2	3
	Shock - N/Plus	63150		
BP-51	Shock	BP5160033	2	
	Fit Kit	VM80010038	1	

FIT KITS & HARDWARE

Loc	Description	Part Number	Qty	Note
F	LOWER CONTROL ARM ADJUST	LCAJLFR		2
F	BUMP STOP KIT	FK92		3
F	SWAY BAR LINK KIT	FK105	1	3
F	UPPER CONTROL ARM ADJUST	UCAJLFR		4
F	PANHARD ROD ADJUSTABLE (LHD)	PANRJL001		4
F	TRIM PACKER	OMEJKPF10	EA	1

REAR SELECTION

Estimated Lift: Sport - 3.5" (90mm) / Rubicon - 2.5" (65mm)

LWB MODELS		Part Number	Qty	Notes
Medium Load	Spring	3137	1	1
	Shock - N/Sport	60151	2	3
	Shock - N/Plus	63151		
Constant 150kg	Spring	3138	1	1
	Shock - N/Sport	60151	2	3
	Shock - N/Plus	63151		
Constant 300kg	Spring	3139	1	1
	Shock - N/Sport	60151	2	3
	Shock - N/Plus	63151		
BP-51	Shock RH	BP5160034R		
	Shock LH	BP5160034L	1	
	Fit Kit	VM80010039		

FIT KITS & HARDWARE

Loc	Description	Part Number	Qty	Notes
R	LOWER CONTROL ARM ADJUST	LCAJKRR		4
R	UPPER CONTROL ARM ADJUST	UCAJKRR	1	4,5
R	PANHARD ROD ADJUSTABLE (LHD)	PANRJL002		4
R	TRIM PACKER	OMEJLPR10	EA	1

Lift increase is approximate and will depend on vehicle weights.

Modifications for off road use only.

The products listed in this selection chart are deemed by Old Man Emu to be suitable for off road use and their legality for public road use should be certified by the relevant Registration Authority. An Off Road Use Only Disclaimer must be signed by the customer.

Modifications and replacement of other associated components will be required.

Comments

1 For trim adjustment use - Front: OMEJKPF10 Rear: OMEJLPR10. Do not fit more than one (1) packer per coil spring.

2 Fitment of LCAJLFR Front Lower Control Arm is **required** to restore wheel alignment castor settings.

3 Fitment of FK92 is **mandatory**. FK92 Bump Stop Kit prevents shock absorbers from going solid for fitment of larger tyres. Fitment of FK105 is **mandatory**. FK105 allows the shocks to extend freely without limit or contact.

4 Fitment not mandatory, however fitment will allow for fine tuning vehicle geometry.

5 Not suitable for models with headlight adjustment, no provision for adjustment link.

FRONT SELECTION

V6 PETROL ENGINE		Part Number	Qty	Notes	
Estimated Lift 50mm	No Bar	Spring	2626	1	1,3,4,5
		Shock - N/Sport	60066	2	2
		Shock - N/Plus	63066		
	Bar Only	Spring	2615	1	1
		Shock - N/Sport	60066	2	2
		Shock - N/Plus	63066		
	Bar/ Winch/ Accessories	Spring	2627	1	1
		Shock - N/Sport	60066	2	2
		Shock - N/Plus	63066		
	BP-51	Shock	BP5160031	2	1
		Fit Kit	VM80010014	1	2

2.8 DIESEL ENGINE		Part Number	Qty	Notes	
Estimated Lift 50mm	No Bar	Spring	2627	1	1,3,4,5
		Shock - N/Sport	60066	2	2
		Shock - N/Plus	63066		
	Bar Only	Spring	2616	1	1
		Shock - N/Sport	60066	2	2
		Shock - N/Plus	63066		
	Bar/ Winch/ Accessories	Spring	2628	1	1
		Shock - N/Sport	60066	2	2
		Shock - N/Plus	63066		
	BP-51	Shock	BP5160031	2	1
		Fit Kit	VM80010014	1	2

FIT KITS & HARDWARE

Loc	Description	Part Number	Qty	Note
F	STEERING DAMPER	OMESD48	1	6
F	STEERING STABILISER MOUNT KIT	FK50		6
F	TRIM PACKER	OMEJKPF10	EA	1
F	CASTER CORRECTION KIT	FK53	1	5

REAR SELECTION

ALL MODELS		Part Number	Qty	Notes	
Est Lift 50mm	Medium Load	Spring	2630	1	
		Shock - N/Sport	60067	2	7
	Constant 150kg	Spring	2617	1	
		Shock - N/Sport	60067	2	7
	BP-51	Shock 2"	BP5160032	2	
		Fit Kit 2"	VM80010024	1	7

FIT KITS & HARDWARE

Loc	Description	Part Number	Qty	Notes
R	PANHARD ROD EXT BKT KIT (LHD)	FK37	1	2
R	PANHARD ROD EXT BKT KIT (RHD)	FK39		
R	TRIM PACKER	OMEJKPR10	EA	1

SUSPENSION KITS

4" Complete Kit	Lift	Part Number	Qty
Petrol RHD	100mm	OMEJK4RHD	1
Diesel RHD	100mm	OMEJK4RHDD	
Petrol LHD	100mm	OMEJK4	
Diesel LHD	100mm	OMEJK4D	

Comments

1 For trim adjustment use - Front: OMEJKPF10 Rear: OMEJKPR10. Do not fit more than 1 packer per coil spring.

2 Fitment of Panhard rod extension bracket kit is not mandatory, however fitment will improve the ride feel by locating the panhard rod to its original position.

3 2012 Models with 3.6L engine will require exhaust or driveshaft modification to avoid contact of driveshaft and exhaust at full droop. When fitting larger than original diameter tyres, it is a requirement to fit aftermarket wheels (rims) that have a greater offset (less backspacing) to ensure that sufficient clearance is given between the tyre to sway bar, sway bar links and control arms.

4 Kit Includes: 2 x Front Shocks, 2 x Rear Shocks, 1 x (pair) Front Coils, 1 x (pair) Rear Coils, 1 x Steering Damper, 1 x Front Forged Panhard, 1 x Bump Stop Kit, 1 x Brakeline Relocation Kit, 1 x Rear Panhard Bracket Kit, 1 x Sway Bar Link Dis-Connect Kit, 1 x Caster & Driveline Kit, 2 x Front Trim Packer, 2 x Rear Trim Packer, 1 x Display Carton. Refer to Chrysler Jeep Wrangler JK Off Road Use Only page for kit breakdown

5 FK53 Caster Kit will increase caster angle by 2 degrees. Check manufacturer's specification if Caster Kit is required.

6 FK50 is a mandatory fitment for 2006 To 2008 Models when fitting OMESD48. Left hand drive only.

7 When remaining stock of N198, 60066 & 60067 is exhausted no further product will be available.

FRONT SELECTION

V6 PETROL ENGINE		Part Number	Qty	Notes	
Estimated Lift 50mm	No Bar	Spring	2627	1	1,3,4,5
		Shock - N/Sport	60066	2	2
		Shock - N/Plus	63066		
	Bar Only	Spring	2616	1	1
		Shock - N/Sport	60066	2	2
		Shock - N/Plus	63066		
	Bar/ Winch/ Accessories	Spring	2628	1	1
		Shock - N/Sport	60066	2	2
		Shock - N/Plus	63066		
	BP-51	Shock	BP5160031	2	1
		Fit Kit	VM80010014	1	2

2.8 DIESEL ENGINE		Part Number	Qty	Notes	
Estimated Lift 50mm	No Bar	Spring	2628	1	1,3,4,5
		Shock - N/Sport	60066	2	2
		Shock - N/Plus	63066		
	Bar Only	Spring	2619	1	1
		Shock - N/Sport	60066	2	2
		Shock - N/Plus	63066		
	Bar/ Winch/ Accessories	Spring	2629	1	1
		Shock - N/Sport	60066	2	2
		Shock - N/Plus	63066		
	BP-51	Shock	BP5160031	2	1
		Fit Kit	VM80010014	1	2

FIT KITS & HARDWARE

Loc	Description	Part Number	Qty	Note
F	STEERING DAMPER	OMESD48	1	6
F	STEERING STABILISER MOUNT KIT	FK50		
F	TRIM PACKER	OMEJKPF10	EA	1
F	CASTER CORRECTION KIT	FK53	1	5

REAR SELECTION

ALL MODELS		Part Number	Qty	Notes	
Estimated Lift 50mm	Medium Load	Spring	2617	1	
		Shock - N/Sport	60067	2	7
		Shock - N/Plus	63067		
	Constant 150kg	Spring	2618	1	
		Shock - N/Sport	60067	2	7
		Shock - N/Plus	63067		
	Constant 300kg	Spring	2620	1	
		Shock - N/Sport	60067	2	7
		Shock - N/Plus	63067		
	BP-51	Shock	BP5160032	2	
		Fit Kit	VM80010024	1	7

FIT KITS & HARDWARE

Loc	Description	Part Number	Qty	Notes
R	PANHARD ROD EXT BKT KIT (LHD)	FK37	1	2
R	PANHARD ROD EXT BKT KIT (RHD)	FK39		
R	TRIM PACKER	OMEJKPR10	EA	1

SUSPENSION KITS

4" Complete Kit	Lift	Part Number	Qty
Petrol RHD	100mm	OMEJK4RHD	1
Diesel RHD		OMEJK4RHDD	
Petrol LHD		OMEJK4	
Diesel LHD		OMEJK4D	

Comments

- 1 For trim adjustment use - Front: OMEJKPF10
Rear: OMEJKPR10. Do not fit more than 1 packer per coil spring.
- 2 Fitment of Panhard rod extension bracket kit is not mandatory, however fitment will improve the ride feel by locating the panhard rod to its original position.
- 3 2012 Models with 3.6L engine will require exhaust or driveshaft modification to avoid contact of driveshaft and exhaust at full droop. When fitting larger than original diameter tyres, it is a requirement to fit aftermarket wheels (rims) that have a greater offset (less backspacing) to ensure that sufficient clearance is given between the tyre to sway bar, sway bar links and control arms.
- 4 Kit Includes: 2 x Front Shocks, 2 x Rear Shocks, 1 x (pair) Front Coils, 1 x (pair) Rear Coils, 1 x Steering Damper, 1 x Front Forged Panhard, 1 x Bump Stop Kit, 1 x Brakeline Relocation Kit, 1 x Rear Panhard Bracket Kit, 1 x Sway Bar Link Dis-Connect Kit, 1 x Caster & Driveline Kit, 2 x Front Trim Packer, 2 x Rear Trim Packer, 1 x Display Carton. Refer to Chrysler Jeep Wrangler JK Off Road Use Only page for kit breakdown
- 5 FK53 Caster Kit will increase caster angle by 2 degrees. Check manufacturer's specification if Caster Kit is required.
- 6 FK50 is a mandatory fitment for 2006 To 2008 Models when fitting OMESD48. Left hand drive only.
- 7 When remaining stock of N198, 60066 & 60067 is exhausted no further product will be available.

FRONT SELECTION

ALL LWB MODELS		Part Number	Qty	Notes	
Estimated Lift 100mm	Coil Springs	Spring - Petrol	2642	1	
		Spring - Diesel	3047		
	Nitro Sport	Shock - Mid	60066M	2	1
		Shock - Long	60066L		
	Nitro +	Shock - Mid	63066M	2	1
		Shock - Long	63066L		
	BP-51	Shock - Mid	BP5160021	2	1, 2
		Shock - Long	BP5160022		
		Fit Kit	VM80010014	1	

FIT KITS & HARDWARE

Loc	Description	Part Number	Qty	Note	
F	STEERING DAMPER	OMESD48	1	13	
F	STEERING STABILISER MOUNT KIT	FK50		13	
F	CASTER KIT	FK53		3	
F	CASTER & DRIVELINE KIT	FK49		4	
F	BRAKELINE RELOCATION KIT	FK46			
F	SWAY BAR DISCONNECT KIT	FK48		5	
F	SWAY BAR LINK	3460010SP		2	6
F	SWAY BAR LINK BUSH KIT	OMESB3023		EA	7
F	LOWER CONTROL ARM	LCAJKFR		1	8
F	UPPER CONTROL ARM	UCAJKFR			9
F	ADJUSTABLE PANHARD ROD	PANRJK002	1	9	
		PANRJK003			
F	BUMP STOP EXT KIT	FK40			
F	TRIM PACKER	OMEJKPF10	EA	10	

COMPLETE KITS - 100mm (4 Inch)

Description	Part Number	Qty
100mm Kit - Suits Petrol RHD	OMEJK4RHD	1
100mm Kit - Suits Diesel RHD	OMEJK4RHDD	
100mm Kit - Suits Petrol LHD	OMEJK4	
100mm Kit - Suits Diesel LHD	OMEJK4D	

Kit Includes: 2 x Front Shocks, 2 x Rear Shocks, 1 x (pair) Front Coils, 1 x (pair) Rear Coils, 1 x Steering Damper, 1 x Front Forged Panhard, 1 x Bump Stop Kit, 1 x Brakeline Relocation Kit, 1 x Rear Panhard Bracket Kit, 1 x Sway Bar Link Dis-Connect Kit, 1 x Caster & Driveline Kit, 2 x Front Trim Packer, 2 x Rear Trim Packer, 1 x Display Carton.

Lift increase is approximate and will depend on vehicle weights.

Modifications for off road use only.

The products listed in this selection chart are deemed by Old Man Emu to be suitable for off road use and their legality for public road use should be certified by the relevant Registration Authority. An Off Road Use Only Disclaimer must be signed by the customer.

Modifications and replacement of other associated components will be required.

Warranty will be void if the shocks have been used in a racing application.

2012 Models with 3.6L engine will require exhaust or driveshaft modification to avoid contact of driveshaft and exhaust at full droop.

When fitting larger than original diameter tyres, it is a requirement to fit aftermarket wheels (rims) that have a greater offset (less backspacing) to ensure that sufficient clearance is given between the tyre to sway bar, sway bar links and control arms.

Comments

- 1 Shocks are designed around a 100mm coil - compatibility for 75mm & 125mm need to be determined by the installer with open and closed lengths checked as well as bump stop contact measurements.
- 2 BP5160021 4+ Front 633 - Suits OMEJK4 Kits.
BP5160022 4+ Front 683 - Longer travel front shock, other modifications to the vehicle will be required.
- 3 FK53 suits front only. Increases caster by 2 degrees.
- 4 FK49 Adjusts front caster and rear pinon angle.
- 5 FK48 suits 100mm lift.
- 6 3460010SP & 3460011SP suits 100mm lift. Kit is a link only.
- 7 OMESB3023 suits sway bar link 3460010SP.
- 8 LCAJKFR & UCAJKFR - Suits SWB & Unlimited models (1 pair).
- 9 PANRJK002 - suits LHD.
PANRJK003 - suits RHD.
- 10 Coil trim packers may be required to trim vehicles. Each packer is 10mm.
- 11 FK47RHD - suits RHD & 100mm Lift.
FK47 - suits LHD & 100mm Lift.
- 12 LCAJKRR & UCAJKRR - suits SWB & Unlimited Models (1 pair).
- 13 FK50 is a mandatory fitment for 2006 To 2008 Models when fitting OMESD48. Left hand drive only.
- 14 BP5160030, 4+ Rear 685.
VM80010015 4+ Rear.

REAR SELECTION

ALL LWB MODELS			Part Number	Qty	Notes
Est Lift 100mm	Medium Load	Spring	2643	1	
	Constant 300kg	Spring	3046	1	
	Shock	Nitrocharger Sport	60067L	2	1
		Nitrocharger +	63067L		
BP-51	Shock	BP5160030	2	1, 14	
	Fit Kit	VM80010015	1	14	

FIT KITS & HARDWARE

Loc	Description	Part Number	Qty	Note
R	PANHARD BRACKET KIT	FK47	1	11
		FK47RHD		
R	SWAY BAR LINK	3460011SP	2	6
R	LOWER CONTROL ARM	LCAJKRR	1	12
R	UPPER CONTROL ARM	UCAJKRR		
R	BRAKELINE RELOCATION KIT	FK46	1	5
R	SWAY BAR DISCONNECT KIT	FK48		
R	BUMP STOP EXTENSION KIT	FK40	EA	10
R	TRIM PACKER	OMEJKPR10		

Lift increase is approximate and will depend on vehicle weights.

Modifications for off road use only.

The products listed in this selection chart are deemed by Old Man Emu to be suitable for off road use and their legality for public road use should be certified by the relevant Registration Authority. An Off Road Use Only Disclaimer must be signed by the customer.

Modifications and replacement of other associated components will be required.

Warranty will be void if the shocks have been used in a racing application.

2012 Models with 3.6L engine will require exhaust or driveshaft modification to avoid contact of driveshaft and exhaust at full droop.

When fitting larger than original diameter tyres, it is a requirement to fit aftermarket wheels (rims) that have a greater offset (less backspacing) to ensure that sufficient clearance is given between the tyre to sway bar, sway bar links and control arms.

Comments

- 1 Shocks are designed around a 100mm coil - compatibility for 75mm & 125mm need to be determined by the installer with open and closed lengths checked as well as bump stop contact measurements.
- 2 BP5160021 4+ Front 633 - Suits OMEJK4 Kits.
BP5160022 4+ Front 683 - Longer travel front shock, other modifications to the vehicle will be required.
- 3 FK53 suits front only. Increases caster by 2 degrees.
- 4 FK49 Adjusts front caster and rear pinon angle.
- 5 FK48 suits 100mm lift.
- 6 3460010SP & 3460011SP suits 100mm lift. Kit is a link only.
- 7 OMEB3023 suits sway bar link 3460010SP.
- 8 LCAJKFR & UCAJKFR - Suits SWB & Unlimited models (1 pair).
- 9 PANRJK002 - suits LHD.
PANRJK003 - suits RHD.
- 10 Coil trim packers may be required to trim vehicles. Each packer is 10mm.
- 11 FK47RHD - suits RHD & 100mm Lift.
FK47 - suits LHD & 100mm Lift.
- 12 LCAJKRR & UCAJKRR - suits SWB & Unlimited Models (1 pair).
- 13 FK50 is a mandatory fitment for 2006 To 2008 Models when fitting OMESD48. Left hand drive only.
- 14 BP5160030, 4+ Rear 685.
VM80010015 4+ Rear.

FRONT SELECTION

5.7L PETROL & 3.0L DIESEL		Part Number	Qty	Notes	
Est Lift 40-45mm	No Bar	Spring	3163	1	2,4
		Strut - N/Sport	90044	2	1,4
	Bar Only	Spring	3164	1	2,4
		Strut - N/Sport	90044	2	1,4
	Bar/ Winch/ Accessories	Spring	3165	1	2,4
		Strut - N/Sport	90044	2	1,4
	Nitro +	Spring	4035	1	2,4
		Strut - N/Plus	93044	2	1,4

Comments

- 1 No top mounting bushes supplied. Re-use OE Top Hat, Dirt Shield and Bump Stop.
- 2 Trim packer OME95PF5 provides approximately 10mm lift at wheel. Do not fit more than one (1) packer per coil spring.
- 3 Workshop tool FK102 **recommended** for rear shock fitment.
- 4 OME coils and struts must be fitted together due to different winding of the lower coil seat.

FIT KITS & HARDWARE

Loc	Description	Part Number	Qty	Note
F	TRIM PACKER	OME95PF5	EA	2

REAR SELECTION

5.7L PETROL & 3.0L DIESEL		Part Number	Qty	Note	
Est Lift 40-45mm	Medium Load	Spring	3167	1	
		Shock - N/Sport	60164	2	3
		Shock - N/Plus	63164		
	Constant 300kg	Spring	3168	1	
		Shock - N/Sport	*60165 / 60164	2	3
		Shock - N/Plus	*63165 / 63164		
	Constant 600kg	Spring	3169	1	
		Shock - N/Sport	60165	2	3
		Shock - N/Plus	63165		

FIT KITS & HARDWARE

Loc	Description	Part Number	Qty	Note
R	REAR SHOCK TOOL	FK102	EA	3

FRONT SELECTION

ALL MODELS		Part Number	Qty	Notes
Estimated Lift 40mm	No Bar	Spring	3207	1
		Strut - N/Sport	90052	2 1,11,13
	Bar Only	Spring	3208	1
		Strut - N/Sport	*90053 / 90052	2 1,11,13
Bar/ Winch	Spring	3209	1	
	Strut - N/Sport	90053	2 1,11,13	
Bar/ Winch/ Accessories	Spring	3210	1	
	Strut - N/Sport	90053	2 1,11,13	
20mm	No Bar	Spring	3211	1
		Strut - N/Sport	90052	2 1,11,13
Est Lift 20-40mm	Nitrocharger +	Spring - 40mm	4024	1
		Spring - 20mm	4028	
		Strut	*93053 / 93052	2 1,11,13
	MT-64	Spring - 40mm	4024	1
		Spring - 20mm	4028	
		Shock	MT64902001	2
	BP-51	Shock Heavy	MT64902002	1
Strut - RH		BP5190015R		
Strut - LH		BP5190015L		
	Fit Kit	VM80010053		

FIT KITS & HARDWARE

Loc	Description	Part Number	Qty	Note
F	Upper Control Arm	UCA0009	1	
F	Trim Packer	FK112	EA	2

Comments

- 1 OMESB117 suits OE Shackle
OMESB118 bush kit suits OME Greasable shackle OMEGS20
- 2 Use OMEU82 when fitting EL130R/ EL131R
Use OMEU83 when fitting EL132R
- 3 Fitment of Driveline Spacer Kit FK113 is recommended to re-align driveline.
- 4 EL48XL will give approximately 30mm extra lift or increase loading capacity at design height by approximately 300kg.
- 5 FK114 only required for vehicles fitted with upgraded auto levelling head lights.
- 6 FK115 Bump Stop Adapter Kit is optional but highly recommended to save fitment time
- 7 FK116 Diff Breather Extension Kit only required for vehicles fitted with Ad Blue (Europe Only - for other markets check vehicle specs)
- 8 FK95 is a recommended fitment if original leaf spring fixed eye nut bolts are in poor condition. Ensure correct torque specifications are used in supplied fitting instructions.
- 9 Use 60178/ 63178 when adding an EL48XL Extra Leaf to a EL132R Leaf Spring or when carrying constant loads of 800kg and above. EL48XL will give an extra 250-300kg carrying capacity or 20-25mm lift.
- 10 Refer to **Leaf Spring Service Parts** section for Centre Bolt selection.
- 11 Spring selection based on Summit bar. If fitting a Sahara Bar please select down one spring.
- 12 Wildtrack model is approximately 200kg heavier and will result in 10-15mm less in ride height. Trim packers may be required.
- 13 Does not suit OE coil

REAR SELECTION

ALL MODELS		Part Number	Qty	Note	
Estimated Lift 40mm	Medium Load	Leaf Spring	EL130R	2,8,12	
		Shock - N/Sport	60172	2	
		Shock - N/Plus	63172		
		Shock - MT64	MT64602003L	1+1	
		Shock - MT64	MT64602003R		
	Constant 300kg	Leaf Spring	EL131R	2,8,12	
		Shock - N/Sport	*60173 / 60172	2	
		Shock - N/Plus	*63173 / 63172		
		Shock - MT64	MT64602003L	1+1	
		Shock - MT64	MT64602003R		
		Shock - MT64	*MT64602004L		
	Constant 600kg	Leaf Spring	EL132R	2,8,12	
		Shock - N/Sport	*60178 / 60173	2	
		Shock - N/Plus	*63178 / 63173	9	
		Shock - MT64	MT64602004L	1+1	
	BP-51	Shock - RH	BP5160055R		
		Shock - LH	BP5160055L	1	
		Fit Kit	VM80010052		
	Greasable Shackle Kit		OMEGS20	1	
	Greasable Pin Kit		OMEGP10		
Spring Bush Kit		OMESB117	2	1	
		OMESB118			
U-Bolts		OMEU82	4	2	
		OMEU83			
Extra Leaf		EL48XL		9	
Extra Leaf Spacer Kit		ELSK15	2		
Centre Bolt				10	

FIT KITS & HARDWARE

Loc	Description	Part Number	Qty	Note
R	Driveline Spacer Kit	FK113		3
R	Headlight Sensor Bracket	FK114	1	5
R	Bump Stop Adapter Kit	FK115		6
R	Diff Breather Extension Kit	FK116		7
R	Trim Packer	ELSK14	EA	
R	Leaf Spring Front Eye Bolt	FK95		8

Comments

- 1** OMESB117 suits OE Shackle
OMESB118 bush kit suits OME Greasable shackle OMEGS20
- 2** Use OMEU82 when fitting EL130R/ EL131R
Use OMEU83 when fitting EL132R
- 3** Fitment of Driveline Spacer Kit FK113 is recommended to re-align driveline.
- 4** EL48XL will give approximately 30mm extra lift or increase loading capacity at design height by approximately 300kg.
- 5** FK114 only required for vehicles fitted with upgraded auto levelling head lights.
- 6** FK115 Bump Stop Adapter Kit is optional but highly recommended to save fitment time
- 7** FK116 Diff Breather Extension Kit only required for vehicles fitted with Ad Blue (Europe Only - for other markets check vehicle specs)
- 8** FK95 is a recommended fitment if original leaf spring fixed eye nut bolts are in poor condition. Ensure correct torque specifications are used in supplied fitting instructions.
- 9** Use 60178/ 63178 when adding an EL48XL Extra Leaf to a EL132R Leaf Spring or when carrying constant loads of 800kg and above. EL48XL will give an extra 250-300kg carrying capacity or 20-25mm lift.
- 10** Refer to **Leaf Spring Service Parts** section for Centre Bolt selection.
- 11** Spring selection based on Summit bar. If fitting a Sahara Bar please select down one spring.
- 12** Wildtrack model is approximately 200kg heavier and will result in 10-15mm less in ride height. Trim packers may be required.
- 13** Does not suit OE coil

FRONT SELECTION - Estimated Lift 25mm

DIESEL ENGINE		Part Number	Qty	Notes
No Bar	Spring	3181	1	
	Strut	USE OE		1

REAR SELECTION - Estimated Lift 25mm

ALL MODELS		Part Number	Qty	Note
Medium Load	Spring	3182	1	2
	Shock	USE OE		1
Constant 200kg	Spring	3183	1	2
	Shock	USE OE		1

Comments

- 1 Coils only to be fitted to OE struts and shocks.
- 2 Coils are designed to give 25mm lift at designated carrying capacity (medium or constant 200kg). OE ride height will be achieved with extra 200kg over nominated weight (200kg or 400kg).

FRONT SELECTION

DIESEL ENGINE		Part Number	Qty	Notes
Estimated Lift 45mm	No Bar	Spring	3141	1
		Strut - N/Sport	90038	2 1
	Bar Only	Spring	3142	1
		Strut - N/Sport	*90039 / 90038	2 1
	Bar/ Winch/ Accessories	Spring	3143	1
		Strut - N/Sport	90039	2 1
30mm	No Bar	Spring	3140	1
		Strut - N/Sport	90038	2 1
30-45mm	Nitro +	Spring - 45mm	4009	1
		Spring - 30mm	4015	
		Strut - N/Plus	*93039 / 93038	2 1, 15
45mm	BP-51	Coilover RH	BP5190012R	1
		Coilover LH	BP5190012L	
		Fit Kit	VM80010040	

Comments

- 1 No top mounting bushes supplied, re-use OE Top Hat, Dirt Shield and Bump Stop.
- 2 Trim Packer FK94 provides 10mm lift at the wheel.
- 3 Strut Top Hat Kit may be required if original equipment is worn.
- 4 Australia Only. Full OME suspension system must be fitted.
- 5 The OME Upper Control Arm will provide an increase between +2.5 and +3.5 degrees of caster and up to 1.5 degrees of negative camber increase (figures based off an approximate 50mm lift). Please note after fitment of Upper Control Arm a vehicle wheel alignment will be required.
- 6 OMESB117 suits OE Shackle - EL102R/ EL103R/ EL126R/ EL127R/ EL128R.
OMESB102 suits OE Shackle - EL049R/ EL068R/ EL069R
OMESB118 Bush Kit suits OME Greasable Shackle OMEGS20 - EL102R/ EL103R/ EL126R/ EL127R/ EL128R.
OMESB103 suits OME Greasable Shackle OMEGS20 - EL049R/ EL068R/ EL069R
- 7 Use OMEU66 when fitting EL102R/ EL126R.
Use OMEU66A when fitting EL103R/ EL127R/ EL128R.
Use OMEU66B when fitting EL128R with EL34XL.
- 8 Fitment of Driveline Spacer Kit FK57 is recommended to re-align driveline.
- 9 EL34XL will give approximately 30mm extra lift or increase loading capacity at design height by approximately 300kg.
- 10 If a TAD110 Frontier tank is installed in the vehicle, when fitting the FK57 spacer kit, the tank will need to be lowered to allow removal of the centre bearing bolts.
- 11 FK95 is a recommended fitment if original leaf spring fixed eye nut bolts are in poor condition. Ensure correct torque specifications are used in supplied fitting instruction.
- 12 Specific fit kit Ford Licence Accessory (FLA), Refer FLA Application Guide.
- 13 Refer to **Leaf Spring Service Parts** section for Centre Bolt selection.
- 14 OMEGP10 Suits - EL102R/ EL103R/ EL126R/ EL127R / EL128R
OMEGP9 Suits - EL049R/ EL068R
- 15 Does not suit OE Coil

FIT KITS & HARDWARE

Loc	Description	Part Number	Qty	Note
F	UPPER CONTROL ARMS	UCA0002	1	5
F	TRIM PACKER	FK94	EA	2
F	STRUT TOP HAT KIT	OMETH009		3
F	FRONT AXLE UPGRADE LABEL KIT	FAUPX1630	1	4

SERVICE PARTS

Description	Part #	Qty	Note
OME UCA Eye Bush 2pk	UCASP004	1	
OME UCA Ball Joint 1pk	UCASP005	EA	
OME UCA Boot 2pk	UCASP006	1	

REAR SELECTION

ALL MODELS		Part Number	Qty	Notes	
Estimated Lift 40mm	Medium Load	Spring Multi leaf	EL126R	7, 12	
		Shock - N/Sport	*60101 / 60023	2	
		Shock - N/Plus	*63101 / 63023		
	Constant 300kg	Spring Multi leaf	EL127R	7, 12	
		Shock - N/Sport	*60102 / 60101	2	
		Shock - N/Plus	*63102 / 63101		
	Constant 600kg	Spring Multi leaf	EL128R	7, 12	
		Shock - N/Sport	60102	2	
		Shock - N/Plus	63102		
	BP-51	Shock RH	BP5160027R	1	
		Shock LH	BP5160027L		
		Shock RH Heavy	*BP5160037R		
		Shock LH Heavy	*BP5160037L		
		Fit Kit	VM80010012		
GREASABLE SHACKLE KIT		OMEGS20	1	6	
GREASABLE PIN KIT		OMEGP10		14	
SPRING BUSH KIT		OMESB117	2	6	
		OMESB118			
		OMESB102			
		OMESB103			
U BOLTS		OMEU66	4	7	
		OMEU66A			
		OMEU66B			
EXTRA LEAF		EL34XL	2	9	
EXTRA LEAF SPACER KIT		ELSK12			

FIT KITS & HARDWARE

Loc	Description	Part Number	Qty	Notes
R	DRIVELINE SPACER KIT	FK57	1	8, 10
R	TRIM PACKER	ELSK05	EA	
R	LEAF SPRING FRONT EYE BOLT KIT	FK95	EA	11
R	LEAF SPRING ISOLATOR	FK103	PR	12
R	CENTRE BOLT		EA	13

Comments

- 1** No top mounting bushes supplied, re-use OE Top Hat, Dirt Shield and Bump Stop.
- 2** Trim Packer FK94 provides 10mm lift at the wheel.
- 3** Strut Top Hat Kit may be required if original equipment is worn.
- 4** Australia Only. Full OME suspension system must be fitted.
- 5** The OME Upper Control Arm will provide an increase between +2.5 and +3.5 degrees of caster and up to 1.5 degrees of negative camber increase (figures based off an approximate 50mm lift). Please note after fitment of Upper Control Arm a vehicle wheel alignment will be required.
- 6** OMESB117 suits OE Shackle - EL102R/ EL103R/ EL126R/ EL127R/ EL128R.
OMESB102 suits OE Shackle - EL049R/ EL068R/ EL069R
OMESB118 Bush Kit suits OME Greasable Shackle OMEGS20 - EL102R/ EL103R/ EL126R/ EL127R/ EL128R.
OMESB103 suits OME Greasable Shackle OMEGS20 - EL049R/ EL068R/ EL069R
- 7** Use OMEU66 when fitting EL102R/ EL126R.
Use OMEU66A when fitting EL103R/ EL127R/ EL128R.
Use OMEU66B when fitting EL128R with EL34XL.
- 8** Fitment of Driveline Spacer Kit FK57 is recommended to re-align driveline.
- 9** EL34XL will give approximately 30mm extra lift or increase loading capacity at design height by approximately 300kg.
- 10** If a TAD110 Frontier tank is installed in the vehicle, when fitting the FK57 spacer kit, the tank will need to be lowered to allow removal of the centre bearing bolts.
- 11** FK95 is a recommended fitment if original leaf spring fixed eye nut bolts are in poor condition. Ensure correct torque specifications are used in supplied fitting instruction.
- 12** Specific fit kit Ford Licence Accessory (FLA), Refer FLA Application Guide.
- 13** Refer to **Leaf Spring Service Parts** section for Centre Bolt selection.
- 14** OMEGP10 Suits - EL102R/ EL103R/ EL126R/ EL127R / EL128R
OMEGP9 Suits - EL049R/ EL068R

FRONT SELECTION

PETROL ENGINE			Part Number	Qty	Notes
Est Lift 60mm	No Bar	Spring		1	
		Strut - N/Sport		2	1
	Bar Only	Spring		1	7
		Strut - N/Sport		2	1
	Bar/ Winch/ Accessories	Spring		1	
		Strut - N/Sport		2	1

Comments

- 1 No top mounting bushes supplied, re-use OE Top Hat, Dirt Shield and Bump Stop.
- 2 OMESB117 suits OE Shackle.
OMESB118 Bush Kit suits OME Greasable Shackle OMEGS20.
- 3 Use OMEU81 when fitting EL120R.
Use OMEU82 when fitting EL121R.
Use OMEU83 when fitting EL128R.

FIT KITS & HARDWARE

Loc	Description	Part Number	Qty	Note
F	TRIM PACKER		EA	7

REAR SELECTION

ALL MODELS			Part Number	Qty	Notes
Estimated Lift 40mm	Medium Load	Spring Multi leaf		2	3
		Shock - N/Sport			
	Constant 600lbs	Spring Multi leaf		2	3
		Shock - N/Sport			
	Constant 1200lbs	Spring Multi leaf		2	3
		Shock - N/Sport			
GREASABLE SHACKLE KIT				1	
GREASABLE FIXED END PIN KIT					
SPRING BUSH KIT				2	2
U BOLTS				4	3
EXTRA LEAF				2	4

- 4 EL34XL will give approximately 30mm extra lift or increase loading capacity at design height by approximately 600lbs.
- 5 Trim Packer FK94 provides 10mm lift at the wheel.
- 6 FK95 is a recommended fitment if original leaf spring fixed eye nut bolts are in poor condition. Ensure correct torque specifications are used in supplied fitting instruction.
- 7 FK94 Trim Packer required to achieve estimated lift.

FIT KITS & HARDWARE

Loc	Description	Part Number	Qty	Note
R	LEAF SPRING FRONT EYE BOLT		2	6

FRONT SELECTION

PETROL ENGINE			Part Number	Qty	Notes
Est Lift 60mm	No Bar	Spring	3140	1	
		Strut - N/Sport	90040	2	1
	Bar Only	Spring	3140	1	7
		Strut - N/Sport	90040	2	1
	Bar/ Winch/ Accessories	Spring	3141	1	
		Strut - N/Sport	90040	2	1

Comments

- 1 No top mounting bushes supplied, re-use OE Top Hat, Dirt Shield and Bump Stop.
- 2 OMESB117 suits OE Shackle.
OMESB118 Bush Kit suits OME Greasable Shackle OMEGS20.
- 3 Use OMEU81 when fitting EL120R.
Use OMEU82 when fitting EL121R.
Use OMEU83 when fitting EL128R.

FIT KITS & HARDWARE

Loc	Description	Part Number	Qty	Note
F	TRIM PACKER	FK94	EA	7

REAR SELECTION

ALL MODELS			Part Number	Qty	Notes	
Estimated Lift 40mm	Medium Load	Spring Multi leaf	EL120R	2	3	
		Shock - N/Sport	60156			
	Constant 600lbs	Spring Multi leaf	EL121R	2	3	
		Shock - N/Sport	*60157 / 60156			
	Constant 1200lbs	Spring Multi leaf	EL128R	2	3	
		Shock - N/Sport	60157			
	GREASABLE SHACKLE KIT			OMEGS20	1	
	GREASABLE FIXED END PIN KIT			OMEGP10		
	SPRING BUSH KIT			OMESB117	2	2
				OMESB118		
	U BOLTS			OMEU81	4	3
				OMEU82		
OMEU83						
EXTRA LEAF			EL34XL	2	4	

- 4 EL34XL will give approximately 30mm extra lift or increase loading capacity at design height by approximately 600lbs.
- 5 Trim Packer FK94 provides 10mm lift at the wheel.
- 6 FK95 is a recommended fitment if original leaf spring fixed eye nut bolts are in poor condition. Ensure correct torque specifications are used in supplied fitting instruction.
- 7 FK94 Trim Packer required to achieve estimated lift.

FIT KITS & HARDWARE

Loc	Description	Part Number	Qty	Note
R	LEAF SPRING FRONT EYE BOLT	FK95	2	6

FRONT SELECTION

DIESEL ENGINE		Part Number	Qty	Notes
Est Lift 50mm	No Bar	Spring	2997	1 5
		Strut - N/Sport	90019	2 1,5,12
	Bar Only	Spring	2998	1 5
		Strut - N/Sport	*90020 / 90019	2 1,5,12
	Bar/ Winch/ Accessories	Spring	2999	1 5
		Strut - N/Sport	90020	2 1,5,12
30mm	No Bar	Spring	3048	1 5
		Strut - N/Sport	90019	2 1,5,12
30-50mm	Nitro +	Spring - 50mm	4013	1 5
		Spring - 30mm	4025	
		Strut	*93020 / 93019	2 1,5,13
30-40mm	BP-51	Coilover RH	BP5190005R	1 5
		Coilover LH	BP5190005L	
		Fit Kit	VM80010011	

Comments

- 1 No top mounting bushes supplied use OME3135. OE bushes may be re-used if in good condition.
- 2 Trim Packer FK56 provides 10mm lift at the wheel.
- 3 Strut Top Hat Kit may be required if original equipment is worn.
- 4 The OME Upper Control Arm will provide an increase between +2.5 and +3.5 degrees of caster and up to 1.5 degrees of negative camber increase (figures based off an approximate 50mm lift). Please note after fitment of Upper Control Arm a vehicle wheel alignment will be required.
- 5 **Important:** Please refer to TSB003.
- 6 OMESB117 suits OE Shackle & Greasable Shackle Pin Kit OMEGP10 - ¹²EL102R/¹²EL103R/EL126R/EL127R/EL128R.

OMESB102 suits OE Shackle & Greasable Shackle Pin Kit OMEGP9 - EL049R.

OMESB118 Bush Kit suits OME Greasable Shackle OMEGS20 - ¹²EL102R/¹²EL103R/ EL126R/ EL127R/ EL128R.

OMESB103 suits OME Greasable Shackle OMEGS20 - EL049R
- 7 Use OMEU66 when fitting ¹²EL102R/EL126R.

Use OMEU66A when fitting ¹²EL103R/EL127R/EL128R.

Use OMEU66B when fitting EL128R with EL34XL.
- 8 Fitment of Driveline Spacer Kit FK57 is recommended to re-align driveline.
- 9 EL34XL will give approximately 30mm extra lift or increase loading capacity at design height by approximately 300kg.
- 10 If a TAD110 Frontier tank is installed in the vehicle, when fitting the FK57 spacer kit, the tank will need to be lowered to allow removal of the centre bearing bolts.
- 11 Refer to **Leaf Spring Service Parts** section for Centre Bolt selection.
- 12 When remaining stock of 90019, 90020, EL102R & EL103R is exhausted no further product will be available.
- 13 Does not suit OE Coil.

FIT KITS & HARDWARE

Loc	Description	Part Number	Qty	Note
F	UPPER CONTROL ARM	UCA0002	PR	4
F	TRIM PACKER	FK56		2
F	UPPER STRUT BUSHES	OME3135	EA	1
F	STRUT TOP HAT KIT	OMETH006		3

SERVICE PARTS

Description	Part #	Qty	Note
OME UCA Eye Bush 2pk	UCASP004	1	
OME UCA Ball Joint 1pk	UCASP005	EA	
OME UCA Boot 2pk	UCASP006	1	

REAR SELECTION

ALL MODELS		Part Number	Qty	Notes	
Estimated Lift 40mm	Medium Load	Spring Multi leaf	EL126R	7	
		Shock - N/Sport	*60101 / 60023	2	
		Shock - N/Plus	*63101 / 63023	12	
	Constant 300kg	Spring Multi leaf	EL127R	7	
		Shock - N/Sport	*60102 / 60101	2	
		Shock - N/Plus	*63102 / 63101	12	
	Constant 600kg	Spring Multi leaf	EL128R	7	
		Shock - N/Sport	60102	2	
		Shock - N/Plus	63102	12	
	BP-51	Shock RH	BP5160027R	1	
		Shock LH	BP5160027L	1	
		Shock RH Heavy	*BP5160037R	1	
		Shock LH Heavy	*BP5160037L	1	
		Fit Kit	VM80010012	1	
	GREASABLE SHACKLE KIT		OMEGS20	1	6
	GREASABLE PIN KIT		OMEGP10 OMEGP9		
	SPRING BUSH KIT		OMESB117	2	6
			OMESB118		
OMESB102					
OMESB103					
U BOLTS		OMEU66	4	7	
		OMEU66A			
		OMEU66B			
EXTRA LEAF		EL34XL	2	9	
EXTRA LEAF SPACER KIT		ELSK12			

FIT KITS & HARDWARE

Loc	Description	Part Number	Qty	Notes
R	DRIVELINE SPACER KIT	FK57	1	8,10
R	TRIM PACKER	ELSK05	EA	11
R	CENTRE BOLT			

Comments

- 1** No top mounting bushes supplied use OME3135. OE bushes may be re-used if in good condition.
- 2** Trim Packer FK56 provides 10mm lift at the wheel.
- 3** Strut Top Hat Kit may be required if original equipment is worn.
- 4** The OME Upper Control Arm will provide an increase between +2.5 and +3.5 degrees of caster and up to 1.5 degrees of negative camber increase (figures based off an approximate 50mm lift). Please note after fitment of Upper Control Arm a vehicle wheel alignment will be required.
- 5 Important:** Please refer to TSB003.
- 6** OMESB117 suits OE Shackle & Greasable Shackle Pin Kit OMEGP10 - ¹²EL102R/¹²EL103R/EL126R/EL127R/EL128R.

OMESB102 suits OE Shackle & Greasable Shackle Pin Kit OMEGP9 - EL049R.

OMESB118 Bush Kit suits OME Greasable Shackle OMEGS20 - ¹²EL102R/¹²EL103R/ EL126R/ EL127R/ EL128R.

OMESB103 suits OME Greasable Shackle OMEGS20 - EL049R
- 7** Use OMEU66 when fitting ¹²EL102R/EL126R.

Use OMEU66A when fitting ¹²EL103R/EL127R/EL128R.

Use OMEU66B when fitting EL128R with EL34XL.
- 8** Fitment of Driveline Spacer Kit FK57 is recommended to re-align driveline.
- 9** EL34XL will give approximately 30mm extra lift or increase loading capacity at design height by approximately 300kg.
- 10** If a TAD110 Frontier tank is installed in the vehicle, when fitting the FK57 spacer kit, the tank will need to be lowered to allow removal of the centre bearing bolts.
- 11** Refer to **Leaf Spring Service Parts** section for Centre Bolt selection.
- 12** When remaining stock of 60023, 60101, 60102, EL102R & EL103R is exhausted no further product will be available.

FRONT SELECTION

PETROL & DIESEL ENGINE		Part Number	Qty	Notes
Over 60kg	Torsion Bars	303013	1	5
	Torsion Bars	303005		
	Strut - N/Sport	60022	2	1,7
	Strut - N/Plus	63022		

FIT KITS & HARDWARE

Loc	Description	Part Number	Qty	Note
F	FITTING KIT	FK22	1	1

REAR SELECTION

DIESEL ENGINE		Part Number	Qty	Notes	
Estimated Lift 20mm	Medium Load	Spring Multi leaf	CS056R	2	2,3,4
		Shock - N/Sport	60023		7
		Shock - N/Plus	63023		
	Constant 200kg	Spring Multi leaf	EL049R	2	2,3,4
		Shock - N/Sport	60023		7
		Shock - N/Plus	63023		
	Constant 400kg	Spring Multi leaf	CS060R	2	2,3,4
		Shock - N/Sport	*60102 / 60023		7
		Shock - N/Plus	*63102 / 63023		
		GREASABLE SHACKLE KIT	OMEGS18	1	
		GREASABLE PIN KIT	OMEGP14		
		U BOLTS	OMEU66	4	3
			OMEU66A		
		SPRING BUSH KIT	OMESB97	2	

FIT KITS & HARDWARE

Loc	Description	Part Number	Qty	Note
R	EXTRA LEAF	D34XL	2	4
		EL34XL		
R	CENTRE BOLT			6

Comments

1 FK22 Front Shock Absorber Upper Mount Support Bracket Kit is a **mandatory** fitment.

2 Include tray weight in constant load calculation.

3 Use OMEU66 when fitting CS056R and EL049R. Use OMEU66A when fitting CS060R.

4 D34XL and UCB19 suits CS056R and CS060R. EL34XL suits EL049R.

5 For Models with 2.5TD engine measure length of Torsion Bar to determine correct fitment.
303005 - 925mm.
303013 - 1024mm.

All other variants use Part # **303013**.

6 Refer to **Leaf Spring Service Parts** section for Centre Bolt selection.

7 When remaining stock of 60023, 60102, N187 and N194 is exhausted no further product will be available.

Remarks:

Some South American Models, built in Argentina, use torsion bars with hexagonal ends. OME suspension is not suitable for these Models.

FRONT SELECTION - Base, Big Bend, Outer Banks, Wildtrak

2.3L PETROL (GAS) ENGINE		Part Number	Qty	Notes	
Estimated Lift 50mm	No Bar	Spring	3198	1	1
		Strut - N/Sport	90047	2	1
	Bar Only	Spring	3198	1	1
		Strut - N/Sport	90047	2	1
	Bar/ Winch/ Accessories	Spring	3199	1	1
		Strut - N/Sport	90047	2	1

Comments

- 1 No top mounting bushes supplied, re-use OE bushes. OME struts and coils must be fitted together due to spring seat design.
- 2 Fitment of OMESTAB10 is highly recommended for improved control in loaded scenarios
- 3 Fitment of FK110 & FK111 for fine tuning ride heights
- 4 Fitment of Panhard Relocation Bracket is a mandatory fitment

2.7L PETROL (GAS) ENGINE		Part Number	Qty	Notes	
Estimated Lift 50mm	No Bar	Spring	3198	1	1
		Strut - N/Sport	90047	2	1
	Bar Only	Spring	3199	1	1
		Strut - N/Sport	90047	2	1
	Bar/ Winch/ Accessories	Spring	3200	1	1
		Strut - N/Sport	90047	2	1

FRONT SELECTION - Black Diamond, Badlands

2.3L PETROL (GAS) ENGINE		Part Number	Qty	Notes	
Estimated Lift 50mm	No Bar	Spring	3198	1	1
		Strut - N/Sport	90047	2	1
	Bar Only	Spring	3199	1	1
		Strut - N/Sport	90047	2	1
	Bar/ Winch/ Accessories	Spring	3200	1	1
		Strut - N/Sport	90047	2	1

2.7L PETROL (GAS) ENGINE		Part Number	Qty	Notes	
Estimated Lift 50mm	No Bar	Spring	3199	1	1
		Strut - N/Sport	90047	2	1
	Bar Only	Spring	3199	1	1
		Strut - N/Sport	90047	2	1
	Bar/ Winch/ Accessories	Spring	3200	1	1
		Strut - N/Sport	90047	2	1

FIT KITS & HARDWARE

Loc	Description	Part Number	Qty	Note
F	Upper Control Arm	UCA0011	EA	
F	Trim Packer	FK110	EA	3
F	Front Sway Bar (Mandatory)	OMESTAB10	EA	2

REAR SELECTION

ALL MODELS		Part Number	Qty	Note	
Estimated Lift 55mm	Medium Load	Spring	3204	1	1
		Strut- N/Sport	90048	2	1
	Constant 150kg	Spring	3205	1	1
		Strut- N/Sport	90048	2	1
	Constant 300kg	Spring	3206	1	1
		Strut- N/Sport	90048	2	1

FIT KITS & HARDWARE

Loc	Description	Part Number	Qty	Note
R	Panhard Relocation Kit	FK109	1	4
R	Trim Packer Kit	FK111	1	3

FRONT SELECTION

PETROL & DIESEL ENGINES		Part Number	Qty	Notes
Over 60kg	Torsion Bars	303005	1	
	Shock - N/Sport	60022	2	1
	Shock - N/Plus	63022		

FIT KITS & HARDWARE

Loc	Description	Part Number	Qty	Note
F	FITTING KIT	FK22	1	1

REAR SELECTION

ALL MODELS		Part Number	Qty	Notes		
Estimated Lift 20mm	Medium Load	Spring Multi leaf	CS026R	2		
		Shock - N/Sport	60023	2	1	
		Shock - N/Plus	63023			
	Constant 200kg	Spring Multi leaf	CS027R	2	2	
		Shock - N/Sport	60023			1
		Shock - N/Plus	63023			
	GREASABLE SHACKLE KIT		OMEGS18	1		
	U BOLTS		OMEU65	4		
	SPRING BUSH KIT		OMESB82	2		

FIT KITS & HARDWARE

Loc	Description	Part Number	Qty	Note
R	EXTRA LEAF	D9XL	2	
R	CENTRE BOLT			3

Comments

- 1** FK22 support brackets must be installed to upper front shock mounting brackets on late 1996 on Models manufactured in Thailand.
- 2** Include tray weight in constant load calculation.
- 3** Refer to **Leaf Spring Service Parts** section for Centre Bolt selection.

FRONT SELECTION - Estimated Lift 40mm

DIESEL ENGINE		Part Number	Qty	Notes
No Bar	Spring	3207	1	
	Strut - N/Sport	90052	2	1
Bar Only	Spring	3208	1	
	Strut - N/Sport	*90053 / 90052	2	1
Bar/ Winch/ Accessories	Spring	3209	1	
	Strut - N/Sport	90053	2	1
Nitrocharger +	Spring	4024	1	
	Strut - N/Plus	*93053 / 93052	2	1,4
BP-51	Strut - RH	BP5190015R	1+1	
	Strut - LH	BP5190015L		
	Fit Kit	VM80010053	1	

Comments

- 1** No top mounting bushes supplied re-use OE Top Hat, Dirt Shield and Bump Stop.
- 2** Trim Packer FK112 provides 10mm lift at the wheel.
- 3** Re-use rear OE Top Damper Forged Bracket, Bushes, Dirt Shield, Bump Stops and Fasteners for the assembly of the rear shock.
- 4** Does not suit OE Coil.

FIT KITS & HARDWARE

Loc	Description	Part Number	Qty	Note
F	TRIM PACKER	FK112		2
F	STRUT TOP HAT KIT	TBA	EA	
F	FRONT AXLE UPGRADE LABEL KIT	TBA		

REAR SELECTION - Estimated Lift 40mm

ALL MODELS		Part Number	Qty	Note
Medium Load	Spring	3212	1	
	Shock - N/Sport	60174	2	3
	Shock - N/Plus	63174		
Constant 200kg	Spring	3213	1	
	Shock - N/Sport	*60175 / 60174	2	3
	Shock - N/Plus	*63175 / 63174		
Constant 400kg	Spring	3214	1	
	Shock - N/Sport	60175	2	3
	Shock - N/Plus	63175		
BP-51	Shock LH	BP5160064L	1+1	
	Shock RH	BP5160064R		
	Fit Kit	VM80010064	1	

FRONT SELECTION - Estimated Lift 30mm

DIESEL ENGINE		Part Number	Qty	Notes
No Bar	Spring	3140	1	
	Strut - N/Sport	90038	2	1
Bar Only	Spring	3141	1	
	Strut - N/Sport	*90039 / 90038	2	1
Bar/ Winch/ Accessories	Spring	3142	1	
	Strut - N/Sport	90039	2	1
Nitro +	Spring	4015	1	
	Strut - N/Plus	*93039 / 93038	2	1,6

FIT KITS & HARDWARE

Loc	Description	Part Number	Qty	Note
F	TRIM PACKER	FK94	EA	2
F	STRUT TOP HAT KIT	OMETH009		4
F	FRONT AXLE UPGRADE LABEL KIT	FAUEV1630	1	5

REAR SELECTION - Estimated Lift 30-40mm

ALL MODELS		Part Number	Qty	Note
Medium Load	Spring	3106	1	
	Shock - N/Sport	60144	2	3
	Shock - N/Plus	63144		
Constant 300kg	Spring	3107	1	
	Shock - N/Sport	*60145 / 60144	2	3
	Shock - N/Plus	*63145 / 63144		

Comments

- 1 No top mounting bushes supplied re use OE Top Hat, Dirt Shield and Bump Stop.
- 2 Trim Packer FK94 provides 10mm lift at the wheel.
- 3 Re-use rear OE Top Damper Forged Bracket, Bushes, Dirt Shield, Bump Stops and Fasteners for the assembly of the rear shock.
- 4 Strut Top Hat Kit may be required if original equipment is worn.
- 5 Australia Only. Full OME suspension system must be fitted.
- 6 Does not suit OE Coil.

FRONT SELECTION - Estimated Lift 40mm

DIESEL ENGINE		Part Number	Qty	Notes
No Bar	Spring	3048	1	
	Strut - N/Sport	90019	2	1
Bar Only	Spring	2997	1	
	Strut - N/Sport	*90020 / 90019	2	1
Bar/ Winch/ Accessories	Spring	2998	1	
	Strut - N/Sport	90020	2	1
Nitro +	Spring	4025	1	
	Strut - N/Plus	*93020 / 93019	2	5

Comments

- 1** No top mounting bushes supplied use OME3135. OE bushes may be re-used if in good condition.
- 2** Trim Packer FK56 provides 10mm lift at the wheel.
- 3** Strut Top Hat Kit may be required if original equipment is worn. This kit includes rubber bushing.
- 4** Re-use rear OE top damper forged bracket, bushes, dirt shield, bumpstops and fasteners for the assembly of the rear shock.
- 5** Does not suit OE Coil.

FIT KITS & HARDWARE

Loc	Description	Part Number	Qty	Note
F	TRIM PACKER	FK56	EA	2
F	STRUT TOP HAT KIT	OMETH006	2	3
F	UPPER STRUT BUSHES	OME3135		1

REAR SELECTION - Estimated Lift 40mm

ALL MODELS		Part Number	Qty	Note
Medium Load	Spring	3106	1	
	Shock - N/Sport	60144	2	4
	Shock - N/Plus	63144		
Constant 300kg	Spring	3107	1	
	Shock - N/Sport	*60145 / 60144	2	4
	Shock - N/Plus	*63145 / 63144		

FRONT SELECTION

PETROL & DIESEL ENGINE		Part Number	Qty	Notes
Over 50kg	Torsion Bars	-		
	Shock - N/Charger	N16	2	

Comments

1 Raise or lower front end clearance and trim vehicle by adjusting front torsion bars. **Important:** A minimum of 60mm of droop **must** be maintained.

REAR SELECTION - Estimated Lift 40mm

REAR LEAF MODELS		Part Number	Qty	Notes
Medium Load	Spring Multi leaf	CS042R	2	2
	Shock - N/Sport	N17		

2 OE spring bushes are required to fit CS042R springs. D10XL Extra Leaf should be fitted when a constant 200kg plus load is carried.

FIT KITS & HARDWARE

Loc	Description	Part Number	Qty	Note
R	EXTRA LEAF	D10XL	2	2
R	CENTRE BOLT			3

3 Refer to **Leaf Spring Service Parts** section for Centre Bolt selection.

FRONT SELECTION - Estimated Lift 45mm

DIESEL ENGINE		Part Number	Qty	Notes
No Bar	Spring 45mm	2768	1	
	Shock - N/Sport	60123	2	

FRONT SELECTION - Estimated Lift 75-100mm

DIESEL ENGINE		Part Number	Qty	Notes
No Bar	Spring 75mm	3075	1	1
	Shock - N/Sport	60121	2	2, 7
Bar Only	Spring 100mm	3076	1	1
	Shock - N/Sport	60121	2	2, 7

FIT KITS & HARDWARE

Loc	Description	Part Number	Qty	Note
F	CASTER CORRECTION KIT	FK81		6
F	PANHARD BRACKET	FK69		
F	RADIUS ARM DROP BRACKET KIT	FK80	1	2, 7
		FK70		
F	BRAKELINE BRACKET KIT	FK71		
F	SWAYBAR BRACKET KIT	FK72		
F	BUMP SPACER KIT	FK73		
F	TRIM PACKER (10mm)	FK74	EA	3

REAR SELECTION - Estimated Lift 75mm

ALL MODELS		Part Number	Qty	Note
Medium Load	Spring	EL077R	2	4
	Shock - N/Sport	60122		
Constant 450kg	Spring	EL077R	2	4
	Extra Leaf	EL40XL		
	Shock - N/Sport	60122		

FIT KITS & HARDWARE

Loc	Description	Part Number	Qty	Note
R	SPRING BUSH KIT	OMESB109	2	
R	U BOLTS - NO OVERLOAD LEAF	OMEU77	4	5
		OMEU79		
R	U BOLTS - WITH OVERLOAD LEAF	OMEU78		
		OMEU80		
R	EXTRA LEAF	EL40XL	2	
R	CENTRE BOLT - OVERLOAD ONLY	UCB21		4

Comments

1 When fitting either 3075 or 3076 it is **mandatory** to fit Bump Spacer Kit FK73 to prevent the coil from being over stressed.

2 OME Front shock 60121 is not suitable as an OE replacement. When fitting our longer OME shock 61021 you must fit:

- FK71 Brakeline Kit to extend / drop the brakelines
- FK72 Swaybar Kit to lower the front Swaybar
- ⁷FK70 or ⁷FK80 Radius Arm drop Bracket Kit, if not fitted you may over stretch the front brakelines

3 When bull bar and / or winch are fitted use FK74 on both coils to restore nominal lift height.

4 Where the OE rear leaf spring has an overload leaf fitted, this overload leaf is to be fitted to the OME leaf, EL077R is to have its centre bolt replaced with a longer bolt UCB21 and OE spacer blocks are to be reused.

5 Use OMEU77 / OMEU79 when fitting to a vehicle without an overload leaf. Use OMEU78 / OMEU80 when fitting to a vehicle with an overload leaf.

2011-2017 USE: OMEU77 / OMEU78
2008-2010 USE: OMEU79 / OMEU80

6 Fitment of a FK81 Caster Correction Kit will provide approximately 3.5 to 4.0 degrees of extra caster. It is advisable to have a front end alignment carried out to determine if a FK81 kit is required.

7 FK70 suits - 2011-2017
FK80 suits - 2008-2010

FRONT SELECTION - Estimated Lift 45mm

V8 DIESEL: COIL SPRUNG		Part Number	Qty	Notes
Bar/ Winch/ Accessories	Spring To 100kgs	2768	1	
	Shock - N/Charger	N195	2	

FIT KITS & HARDWARE

Loc	Description	Part Number	Qty	Note
F	CASTER CORRECTION KIT	FK36	1	4

REAR SELECTION

ALL MODELS: LEAF SPRING		Part Number	Qty	Note	
Estimated Lift 50mm	Medium Load	Leaf Spring	CS048R	2	
		Third Stage	TSXL01		
		Shock - N/Charger	N179		
	Constant 600+kgs	Leaf Spring	CS048R	2	
		XL Leaf	D27XL		
		Centre Bolt	UCB10		
		Shock - N/Charger	N179		
	U BOLTS - NO OVERLOAD LEAF		OMEU68	4	1
	U BOLTS - OVERLOAD LEAF		OMEU67		
	FITTING KIT		FK31	1	3
		FK35			
SPACER KIT		OMESK1			

Comments

- 1 Springs are supplied with bushes fitted. Where the OE spring has an overload leaf fitted, it must be replaced with a TSXL01 and the CS048R original centre bolt replaced by a UCB10, the original spacing block must also be re-fitted using U Bolts OMEU67.
- 2 To maintain 50mm lift for loads over constant 600kgs add one D27XL Extra
- 3 Fitment of Driveline Spacer Kit FK31 for Crew Cab or FK35 for Xtra Cab is recommended to reduce possible driveline vibration. If required, additional spacing down of the centre bearing can be achieved by using an OMESK1 Spacer Kit.
- 4 Fitment of a FK36 Caster Correction Kit will provide approximately 3.5 to 4.0 degrees of extra caster. It is advisable to have a Front End Alignment carried out to determine if an FK36 kit is required.

FRONT SELECTION - Estimated Lift 50mm

F250 & F350 PETROL & DIESEL		Part Number	Qty	Notes
Up to 150kg	Leaf Spring	CS018F	1	1,6
	Strut - N/Charger	N178	2	

FIT KITS & HARDWARE - F250

Loc	Description	Part Number	Qty	Note
F	ADJUSTABLE PANHARD ROD	APRF250	1	1
F	U BOLTS - USA MODELS	OMEU69	2+2	8
		OMEU69A		
F	U BOLTS - BRAZIL MODELS	OMEU70	2+2	
		OMEU70A		

FIT KITS & HARDWARE - F350

Loc	Description	Part Number	Qty	Note
F	ADJUSTABLE PANHARD ROD	APRF250	1	1
F	U BOLTS - USA MODELS	OMEU69	4	8

REAR SELECTION

F250 ALL MODELS		Part Number	Qty	Notes	
Estimated Lift 50mm	Constant 300kg	Leaf Spring	CS048R	2	
		Single Fitment	N179		
		Dual Fitment	N179 + N180	2+2	2
	Constant 600kg	Leaf Spring	CS048R	2	3
		XL Leaf	D27XL		3
		Single Fitment	N179	2+2	2
Dual Fitment		N179 + N180			

F350 ALL MODELS - Single Fitment		Part Number	Qty	Notes	
Estimated Lift 50mm	Constant 300kg	Leaf Spring	CS048R	2	
		Third Stage	TSXL01		
		Shock - N/Charger	N179		
	Constant 600kg	Leaf Spring	CS048R	2	3,5,7
		XL Leaf	D27XL		3
		Third Stage	TSXL01		5
		Shock - N/Charger	N179		

FIT KITS & HARDWARE

Loc	Description	Part Number	Qty	Notes
R	U BOLTS	OMEU68	4	7
		OMEU67		
R	FITTING KIT	FK31	1	4
		FK35		
R	STONE GUARD KIT	OME660	1	2
R	CENTRE BOLT		2	9

Comments

1 APRF250 Adjustable Panhard Rod **must** be fitted to allow original axle location to be restored, bushes are supplied in Rod.

2 For F250 Models with dual shock fitment, N179 **must** be fitted rear of the axle as it is longer than the N180. For Both F250 and F350 Models OME660 stone shields are also a recommended fitment to the rear shocks.

3 To help maintain 50mm lift, add one D27XL Extra Leaf for every 400kgs carried over 600kgs.

4 Fitment of FK31 to Crew Cab or FK35 to Extra Cab Models is recommended to reduce possible driveline vibrations

5 F350: As the CS048R has a different spring camber compared to the original spring, the overload leaf **must** be replaced with a TSXL01. The original spacing block **must** be refitted.

6 Springs are supplied with bushing.

7 OMEU68 Suits - F250
OMEU67 Suits - F350

8 USA F350 Models use 4 x OMEU69
USA F250 Models use 2 x OMEU69 &
2 x OMEU69A
Brazil F250 Models use 2 x OMEU70
2 x OMEU70A

9 Refer to **Leaf Spring Service Parts** section for Centre Bolt selection.

FRONT SELECTION

ALL MODELS		Part Number	Qty	Notes
Bar/ Winch/ Accessories	Torsion Bars	-	1	1
	Shock - N/Sport	60031	2	
	Shock - N/Plus	63031		

Comments

1 Raise or lower front end clearance and trim vehicle by adjusting front torsion bars. **Important:** A minimum of 60mm of droop **must** be maintained.

REAR SELECTION - Estimated Lift 20mm

ALL MODELS		Part Number	Qty	Note
Medium Load	Spring	2919	1	2
	Shock - N/Sport	60074	2	
	Shock - N/Plus	63074		
Constant 100kg	Spring	2929	1	
	Shock - N/Sport	60074	2	
	Shock - N/Plus	63074		

2 Coil must be installed with progressive rate to the top.

JACKAROO/ TROOPER & MONTEREY

1992 TO 2/2001 SWB & LWB

GLOBAL

172

181

FRONT SELECTION

ALL MODELS		Part Number	Qty	Notes
Bar/ Winch/ Accessories	Torsion Bars	-	1	1
	Shock - N/Sport	60031	2	
	Shock - N/Plus	63031		

Comments

1 Raise or lower front end clearance and trim vehicle by adjusting front torsion bars. **Important:** A minimum of 60mm of droop **must** be maintained.

REAR SELECTION - Estimated Lift 25mm

ALL MODELS		Part Number	Qty	Note
Medium Load	Spring	2912	1	2
	Shock - N/Sport	60074	2	
	Shock - N/Plus	63074		
Constant 100kg	Spring	2919	1	
	Shock - N/Sport	60074	2	
	Shock - N/Plus	63074		

2 Coil must be installed with progressive rate to the top.

FRONT SELECTION

ALL MODELS		Part Number	Qty	Notes
Bar/ Winch/ Accessories	Torsion Bars	303004	1	1
	Shock - N/Sport	60031	2	6
	Shock - N/Plus	63031		

Comments

1 Raise or lower front end clearance and trim vehicle by adjusting front torsion bars.

Torsion bar 303004 suits Models from 8/88 to 3/92 only.

REAR SELECTION

OVER 50KGS - ALL MODELS		Part Number	Qty	Note	
Estimated Lift 20mm	Medium Load	Leaf Spring	CS028R	2	
		Shock - N/Sport L	60009	1+1	2,6
		Shock - N/Sport R	60032		
		Shock - N/Plus L	63009		
		Shock - N/Plus R	63032		
	Leaf Spring	CS029R	2		
	Constant 200kg	Shock - N/Sport L	*60063 / 60009	1+1	2
		Shock - N/Sport R	*60064 / 60032		
		Shock - N/Plus L	*63063 / 63009		
		Shock - N/Plus R	*63064 / 63032		
SPRING BUSH KIT		OMESB80	2	2	
U BOLTS		OMEU59A	4	3	
GREASABLE SHACKLE KIT		OMEGS13	1	4	

Important: A minimum of 60mm of droop **must** be maintained.

2 60009 / 60063: Suits 11/'86 To 3/'92 Models and requires OMEB11 Bush Kit to convert lower bush from 19mm to 16mm ID.

60064 / 60032 / N89⁶: Suits Models '82 to 10/'86 (no Bush Kit required).

3 Where the OE spring has four leaves OMEU59A U Bolts are required.

4 FK14 Anti Inversion Kit must be fitted if greasable shackles are not fitted.

5 Refer to **Leaf Spring Service Parts** section for Centre Bolt selection.

6 When remaining stock of 60031, 60032, 60064 and N89 is exhausted no further product will be available.

FIT KITS & HARDWARE

Loc	Description	Part Number	Qty	Note
R	SHOCK BUSH KIT CONVERTER	OMEB11	1	
R	ANTI INVERSION KIT	FK14		4
R	EXTRA LEAF	D19XL	2	
R	CENTRE BOLT			5

FRONT SELECTION

ALL MODELS		Part Number	Qty	Notes
Bar/ Winch/ Accessories	Torsion Bars	-	1	
	Shock - N/Sport	60031	2	1
	Shock - N/Plus	63031		

Comments

1 When remaining stock of N102 and 60031 is exhausted no further product will be available.

REAR SELECTION - Estimated Lift 20mm

1999 TO 6/2003 MODELS		Part Number	Qty	Note
Medium Load	Spring	2913	1	
	Shock - N/Sport	N102	2	1

REAR SELECTION - Estimated Lift 40mm

1995 TO 1998 2 & 4 DR UT MODELS		Part Number	Qty	Note
Medium Load	Spring	2912	1	
	Shock - N/Sport	60074	2	
	Shock - N/Plus	63074		

FRONT SELECTION

DIESEL ENGINE		Part Number	Qty	Notes
Estimated Lift 30mm	No Bar	Spring	2883	1
		Strut - N/Sport	90045	2
	Bar Only	Spring	3114	1
		Strut - N/Sport	*90046 / 90045	2
	Bar/ Winch	Spring	2884	1
		Strut - N/Sport	90046	2
	Bar/ Winch/ Accessories	Spring	2885	1
		Strut - N/Sport	90046	2
	Nitro +	Spring	4001	1
		Strut	*93046 / 93045	2

Comments

- 1 No top mounting bushes supplied, use OME3134. OE bushes may be re-used if in good condition. OME struts can only be installed with OME coils.
- 2 Strut Top Hat Kit may be required if original equipment is worn.
- 3 Does not suit OE Coil

FIT KITS & HARDWARE

Loc	Description	Part Number	Qty	Note
F	TRIM PACKER	OME95PF5		
F	UPPER STRUT BUSHES	OME3134	EA	
F	STRUT TOP HAT KIT	OMETH004		

REAR SELECTION

ALL MODELS		Part Number	Qty	Notes
Estimated Lift 40-50mm	Medium Load	Spring	3088	1
		Shock - N/Sport	60130	2
		Shock - N/Plus	63130	
	Constant 200KG	Spring	3089	1
		Shock - N/Sport	*60131 / 60130	2
		Shock - N/Plus	*63131 / 63130	
	Constant 400kg	Spring	3090	1
		Shock - N/Sport	60131	2
		Shock - N/Plus	63131	

TRAILBLAZER 2017 ON

COLORADO 7 2013 TO 2016 ALL MODELS

MU-X 2013 TO 2020 ALL MODELS

GLOBAL

FRONT SELECTION

DIESEL ENGINE		Part Number	Qty	Notes
Estimated Lift 30mm	No Bar	Spring	3057	1
		Strut - N/Sport	90022	2
	Bar Only	Spring	2883	1
		Strut - N/Sport	*90023 / 90022	2
Bar/ Winch/ Accessories	Spring	2869	1	
	Strut - N/Sport	90023	2	
Nitro +	Spring	4018	1	
	Strut - N/Plus	*93023 / 93022	2	

Comments

1 No top mounting bushes supplied, use OME3134. OE bushes may be re-used if in good condition. OME struts can only be installed with OME coils.

2 Colorado 04/13 onwards, due to change in top hat OMESB3014 will be required for fitment of OME coils. Please note: Only needed for up to 2015 Models. Not required for Trailblazer 2017 On Models or Isuzu MU-X.

3 Strut Top Hat Kit may be required if original equipment is worn.

4 60130 and 60131 **cannot** be used as a shock only OE replacement on Colorado 7/Trailblazer Models. Can be used as an OE replacement for Isuzu MU-X.

5 Does not suit OE Coil

FIT KITS & HARDWARE

Loc	Description	Part Number	Qty	Note
F	TRIM PACKER	OME95PF5	PR	
F	UPPER STRUT BUSHES	OME3134		1
F	COIL ISOLATOR	OMESB3014	EA	2
F	STRUT TOP HAT KIT	OMETH004		3

REAR SELECTION

MU-X		Part Number	Qty	Notes
Estimated Lift 40mm	Medium Load	Spring	3088	1
		Shock - N/Sport	60130	2
		Shock - N/Plus	63130	
	Constant 200KG	Spring	3089	1
		Shock - N/Sport	*60131 / 60130	2
		Shock - N/Plus	*63131 / 63130	
Constant 400kg	Spring	3090	1	
	Shock - N/Sport	60131	2	
	Shock - N/Plus	63131		

COLORADO 7 & TRAILBLAZER		Part Number	Qty	Notes
Estimated Lift 40mm	Medium Load	Spring	3091	1
		Shock - N/Sport	60130	2
		Shock - N/Plus	63130	
	Constant 200KG	Spring	3092	1
		Shock - N/Sport	*60131 / 60130	2
		Shock - N/Plus	*63131 / 63130	
Constant 400kg	Spring	3093	1	
	Shock - N/Sport	60131	2	
	Strut - N/Plus	63131	2	

FRONT SELECTION

DIESEL ENGINE			Part Number	Qty	Notes
Est Lift 30mm	No Bar	Spring	2883	1	
		Strut - N/Sport	90037	2	1
	Bar Only	Spring	3114	1	
		Strut - N/Sport	90037	2	1
	Bar/ Winch/ Accessories	Spring	2884	1	
		Strut - N/Sport	90037	2	1

PETROL/ GAS ENGINE			Part Number	Qty	Notes
Est Lift 30mm	No Bar	Spring	3057	1	
		Strut - N/Sport	90037	2	1
	Bar Only	Spring	3058	1	
		Strut - N/Sport	90037	2	1
	Bar/ Winch/ Accessories	Spring	2869	1	
		Strut - N/Sport	90037	2	1

FIT KITS & HARDWARE

Loc	Description	Part Number	Qty	Note
F	TRIM PACKER	OME95PF5	EA	2

REAR SELECTION

ALL MODELS			Part Number	Qty	Notes	
Estimated Lift 30mm	Medium Load	Multi Leaf Spring	EL100R	2		
		Shock - N/Sport	60148			
	Constant 660lbs	Multi Leaf Spring	EL101R	2	6	
		Shock - N/Sport	60149			
	U BOLTS (required)			OMEU81	4	
	REAR SPRING BUSH KIT (required)			OMESB116	2	
LEAF SPRING BOLT FIT KIT (required)			FK91	EA	3	

FIT KITS & HARDWARE

Loc	Description	Part Number	Qty	Note
R	EXTRA LEAF	EL47XL	2	
R	TRIM PACKER	ELSK05	EA	4
R	CENTRE BOLT			5

Comments

- 1 Reuse OE top hat and mounting bushes.
- 2 5mm trim packer (OME95PF5 is one (1) packer, maximum two (2) per side).
- 3 For leaf spring fitment it is easier to cut OE bolt than to remove the fuel tank.
- 4 10mm trim packer (ELSK05 is one (1) packer, maximum one (1) per side).
- 5 Refer to **Leaf Spring Service Parts** section for Centre Bolt selection.
- 6 Heavy Load.

FRONT SELECTION

3.0 DIESEL ENGINE		Part Number	Qty	Notes
Estimated Lift 40mm	No Bar	Spring	2883	1
		Strut - N/Sport	90045	2 1
	Bar Only	Spring	3114	1
		Strut - N/Sport	*90046 / 90045	2 1
	Bar/ Winch	Spring	2884	1
		Strut - N/Sport	90046	2 1
	Bar/ Winch/ Accessories	Spring	2885	1
		Strut - N/Sport	90046	2 1
	Nitro +	Spring	4001	1
		Strut	*93046 / 93045	2 1,10
	BP-51	Coilover RH	BP5190014R	1
		Coilover LH	BP5190014L	
Fit Kit		VM80010044		

Comments

1 No top mounting bushes supplied use OME3134. OE bushes may be re-used if in good condition. OME struts can only be installed with OME coils.

2 OMESB119 Bush Kit suits OME Greasable Shackle, OMEGS26.

OMESB120 Bush Kit suits OE Shackle.

3 If fitting extra leaf to EL125R, use U Bolt OMEU53B.

4 Handbrake Relocation Bracket FK66 is a required fitment.

5 Strut Top Hat Kit may be required if original equipment is worn. Note: Remove plastic isolator from OMEH004, not required for fitment.

6 LS-M Ute & SX XT Cab Chassis models are fitted with heavy duty leaf springs. Lift results may vary.

7 Australia only. Full OME suspension system must be fitted.

8 Refer to **Leaf Spring Service Parts** section for Centre Bolt selection.

9 Does not use a ball joint cover.

10 Does not suit OE Coil

FIT KITS & HARDWARE

Loc	Description	Part Number	Qty	Note
F	TRIM PACKER	OME95PF5	PR	
F	UPPER STRUT BUSHES	OME3134	EA	1
F	STRUT TOP HAT KIT	OMETH004		5
F	FRONT AXLE UPGRADE KIT	FAUDM1595	1	7
F	UPPER CONTROL ARM	UCA0007	EA	9

REAR SELECTION

ALL MODELS		Part Number	Qty	Notes	
Estimated Lift 40mm	Medium Load	Spring Multi leaf	EL123R	2	
		Shock - N/Sport	60167		
		Shock - N/Plus	63167		
	Constant 300kg	Spring Multi leaf	EL124R	2	
		Shock - N/Sport	*60168 / 60167		
		Shock - N/Plus	*63168 / 63167		
	Constant 600kg	Spring Multi leaf	EL125R	2	
		Shock - N/Sport	60168		
		Shock - N/Plus	63168		
	BP-51	Shock	BP5160050	2	
		Fit Kit	VM80010045	1	
	SPRING BUSH KIT		OMESB119	2	2
			OMESB120		
	U BOLTS		OMEU53A	4	3
			OMEU53B		
	GREASABLE SHACKLE KIT		OMEGS26	1	
GREASABLE PIN KIT		OMEGP9			
HANDBRAKE RELOCATION KIT		FK66			

FIT KITS & HARDWARE

Loc	Description	Part Number	Qty	Notes
R	EXTRA LEAF	EL39XL	2	3
R	TRIM PACKER	ELSK05	EA	
R	EXTRA LEAF SPACER KIT	ELSK12	2	
R	CENTRE BOLT		EA	8

FRONT SELECTION

DIESEL ENGINE		Part Number	Qty	Notes
Estimated Lift 30mm	No Bar	Spring	3057	1
		Strut - N/Sport	90022	2 1
	Bar Only	Spring	2883	1
		Strut - N/Sport	*90023 / 90022	2 1
	Bar/ Winch	Spring	2869	1
		Strut - N/Sport	90023	2 1
Bar/ Winch/ Accessories	Spring	3114	1	
	Strut - N/Sport	90023	2 1	
Nitro +	Spring	4018	1	
	Strut	*93023 / 93022	2 1,9	
BP-51	Coilover RH	BP5190009R	1	
	Coilover LH	BP5190009L		
	Fit Kit	VM80010030		

Comments

1 No top mounting bushes supplied use OME3134. OE bushes may be re-used if in good condition. OME struts can only be installed with OME coils.

2 OMESB98 Bush Kit suits OME Greasable Shackle, OMEGS14. OMESB107 Bush Kit suits OE Shackle.

3 If fitting extra leaf to EL110R, use U Bolt OMEU53B.

4 Handbrake Cable Fit Kit FK66 required for Isuzu DMAX cab chassis and LSM Models. FK87 required for Colorado 2016 On Models.

5 Colorado 04/13 onwards, due to change in top hat OMESB3014 will be required for fitment of OME coils. Please note: Only needed for up to 2015 Models. Not required for Colorado 2016 On Models or Isuzu DMAX.

6 Strut Top Hat Kit may be required if original equipment is worn.

7 OMEU53B is required for fitting BP-51 and VM80010031.

8 Refer to **Leaf Spring Service Parts** section for Centre Bolt selection.

9 Does not suit OE Coil

FIT KITS & HARDWARE

Loc	Description	Part Number	Qty	Note
F	TRIM PACKER	OME95PF5	EA	
F	UPPER STRUT BUSHES	OME3134		1
F	COIL ISOLATOR	OMESB3014	2	5
F	STRUT TOP HAT KIT	OMETH004		6

REAR SELECTION

ALL MODELS		Part Number	Qty	Notes	
Estimated Lift 30mm	Medium Load	Spring Multi leaf	EL108R	2	
		Shock - N/Sport	60116		
		Shock - N/Plus	63116		
	Constant 300kg	Spring Multi leaf	EL109R	2	
		Shock - N/Sport	*60117 / 60116		
		Shock - N/Plus	*63117 / 63116		
	Constant 600kg	Spring Multi leaf	EL110R	2	3
		Shock - N/Sport	60117		
		Shock - N/Plus	63117		
	BP-51	DMAX ONLY			
		Shock RH	BP5160016	2	
		Fit Kit	VM80010031	1	7
	BP-51	COLORADO ONLY			
		Shock LH	BP5160016	1	
		Shock RH	BP5160048		
	Fit Kit	VM80010031	7		
SPRING BUSH		OMESB98	2	2	
		OMESB107			
U BOLTS		OMEU53A	4	3,7	
		OMEU53B			
GREASABLE SHACKLE KIT		OMEGS14	1		
GREASABLE PIN KIT		OMEGP9			
HANDBRAKE CABLE FIT KIT		FK66	1	4	
		FK87			

FIT KITS & HARDWARE

Loc	Description	Part Number	Qty	Notes
R	EXTRA LEAF	EL39XL	2	3,7
R	TRIM PACKER	ELSK05	EA	
R	EXTRA LEAF SPACER KIT	ELSK12	2	
R	CENTRE BOLT		EA	8

DMAX 2008 TO 2011 ALL MODELS

COLORADO RC 2008 TO 2011 ALL MODELS

RODEO RA 2003 TO 2011 ALL MODELS (NOT USA)

DOMESTIC (AUS)

FRONT SELECTION

PETROL & DIESEL ENGINES		Part Number	Qty	Notes
No Bar/ No Load	Torsion Bars	303012	1	1
	Shock - N/Sport	60031	2	5
	Shock - N/Plus	63031		

REAR SELECTION

ALL MODELS		Part Number	Qty	Note	
Estimated Lift 30-50mm	Medium Load	Leaf Spring	CS062R	1	2
		Shock - N/Charger	N89		5
		Shock - N/Sport	60032	2	5
		Shock - N/Plus	63032		
	Constant 300kg	Leaf Spring	CS063R	1	2
		Shock - N/Sport	*60064 / 60032	2	5
		Shock - N/Plus	*63064 / 63032		
	SPRING BUSH KIT		OMESB80	2	
	U BOLTS		OMEU66	4	
	GREASABLE SHACKLE KIT		OMEGS13	1	
GREASABLE FIXED END PIN KIT		OMEGP11			

FIT KITS & HARDWARE

Loc	Description	Part Number	Qty	Note
R	ANTI INVERSION KIT	FK26	1	3
R	EXTRA LEAF	D26XL	2	
R	CENTRE BOLT			4

Comments

1 Raise or lower front end clearance and trim vehicle by adjusting front torsion bars. **Important:** A minimum of 60mm of droop **must** be maintained.

It has been found, due to vehicle manufacturing tolerances, that in some cases front shock absorbers may contact the steering arm when on full lock. Fitter should check for this and where required a small indentation should be made to the body of the shock absorber. 303012 torsion bars have a lighter rate than OE and improve ride comfort for vehicles with no front accessory weight. Due to their heavy rate, the OE torsion bars are suitable for vehicles with front accessory weight.

2 Include tray weight in constant load calculation. CS062R and CS063R can be installed to high height 4x2 Models. OME leaf does **not** fit low height 4x2 Models.

3 FK26 only needed if **not** fitting Greasable Shackle Kit.

4 Refer to **Leaf Spring Service Parts** section for Centre Bolt selection.

5 When remaining stock of N89, 60031, 60032 and 60064 is exhausted no further product will be available.

FRONT SELECTION

PETROL AND DIESEL ENGINES		Part Number	Qty	Notes
Bar/ Winch/ Accessories	Torsion Bars	303004	1	1
	Shock - N/Sport	60031	2	
	Shock - N/Plus	63031		

Comments

1 Raise or lower front end clearance and trim vehicle by adjusting front torsion bars. **Important:** A minimum of 60mm of droop **must** be maintained.

REAR SELECTION

ALL MODELS		Part Number	Qty	Note	
Estimated Lift 30-50mm	Medium Load	Leaf Spring	CS028R	2	3,4
		Shock - N/Sport	60032	2	
		Shock - N/Plus	63032		
	Constant 400kg	Leaf Spring	CS029R	2	3,4
		Shock - N/Sport	*60064 / 60032		
		Shock - N/Plus	*63064 / 63032		
	SPRING BUSH KIT		OMESB80	2	
	U BOLTS		OMEU59A	4	2
	GREASABLE SHACKLE KIT		OMEGS13	1	3
	GREASABLE FIXED END PIN KIT		OMEGP11	1	

2 Vehicles with four leaf OE spring stack require U bolts OMEU59A.

3 FK14 **must** be fitted if OMEGS13 greasable shackles are not fitted.

4 Include tray weight in constant load calculation.

5 Refer to **Leaf Spring Service Parts** section for Centre Bolt selection.

FIT KITS & HARDWARE

Loc	Description	Part Number	Qty	Note
R	ANTI INVERSION KIT	FK14	1	3
R	EXTRA LEAF	D19XL	2	
R	CENTRE BOLT			5

FRONT SELECTION

ALL MODELS		Part Number	Qty	Notes
Estimated Lift 40mm	No Bar	Leaf Spring	CS012FA / B	1+1
		Shock - N/Charger	OME015	2
		Strut - N/Plus	63390	2
	Bar/ Winch	Leaf Spring	CS013FA / B	1+1
		Shock - N/Charger	OME015	2
		Strut - N/Plus	63390	2
	Bar/ Winch	Spring	3145	1
		Strut - N/Sport	60154	2
		Strut - N/Plus	63154	2
	SPRING BUSH KIT		OMESB19	2
U BOLTS		OMEU61	4	
		OMEU62	1	1
FITTING KIT		FK06		
STEERING DAMPER		OMESD30	1	

Comments

- 1 One only OMEU62 may be required on the right hand side inner, on some Models.
- 2 When remaining stock of 60032, 60064, 60154, N89 and OME015 is exhausted no further product will be available.
- 3 Refer to **Leaf Spring Service Parts** section for Centre Bolt selection.

FIT KITS & HARDWARE

Loc	Description	Part Number	Qty	Note
F	TRIM PACKER	TP05	EA	
F	EXTRA LEAF	D20XL	2	
F	CENTRE BOLT			3

REAR SELECTION

ALL MODELS		Part Number	Qty	Note	
Estimated Lift 40mm	Medium Load	Leaf Spring	CS038R	1	
		Shock - N/Charger	N89	2	
		Shock - N/Sport	60032	2	
		Shock - N/Plus	63032	2	
	Constant 400kg	Leaf Spring	CS039R	1	
		Shock - N/Sport	60064	2	
		Shock - N/Plus	63064	2	
	SPRING BUSH KIT		OMESB19	2	
	U BOLTS		OMEU61	4	

FIT KITS & HARDWARE

Loc	Description	Part Number	Qty	Note
R	TRIM PACKER	TP05	EA	
R	EXTRA LEAF	D21XL	2	
R	CENTRE BOLT			3

FRONT SELECTION - Estimated Lift 20mm

ALL MODELS		Part Number	Qty	Notes
Bar/ Winch/ Accessories	Torsion Bars	303014	1+1	1,3
	Strut - N/Sport	90001	2	

REAR SELECTION - Estimated Lift 20mm

ALL MODELS		Part Number	Qty	Note
Medium Load	Leaf Spring	CS059R	1	2
	Shock - N/Sport	60045	2	

FIT KITS & HARDWARE

Loc	Description	Part Number	Qty	Note
R	EXTRA LEAF	D36XL	2	

Comments

- 1** Raise or lower front end clearance and trim vehicle by adjusting front torsion bars. It is **important** that a minimum of 60mm droop is maintained to prevent topping out of the front shock absorbers.
- 2** Springs supplied with bushings.
- 3** When remaining stock of 303014 is exhausted no further product will be available.

FRONT <i>Estimated Lift: 10mm</i>	PETROL & DIESEL ENGINE		
	PART NUMBER	QTY	NOTES
TORSION BARS	-		
NITROCHARGER SPORT	60040	2	

REAR <i>Estimated Lift: 20mm</i>	ALL MODELS		
	PART NUMBER	QTY	NOTES
SPRING: MEDIUM LOAD	2603	1	
NITROCHARGER SPORT	60060	2	
SPRING: CONSTANT 200 KGS	2604	1	
NITROCHARGER SPORT	60060	2	

FRONT <i>Estimated Lift: 20mm</i>	ALL MODELS		
	PART NUMBER	QTY	NOTES
SPRING: NO BAR	2902	1	
NITROCHARGER STRUT	N147S+N148S	1 + 1	2, 3

REAR <i>Estimated Lift: 30mm</i>	LATE 2006 TO 2009 MODELS		
	PART NUMBER	QTY	NOTES
SPRING: MEDIUM LOAD	2622	1	
NITROCHARGER	N205	2	

REAR <i>Estimated Lift: 30mm</i>	2003 TO LATE 2006 MODELS		
	PART NUMBER	QTY	NOTES
SPRING: LIGHT LOAD	2602	1	3
NITROCHARGER	N149	2	1
SPRING: MEDIUM LOAD	2903	1	
NITROCHARGER	N149	2	1

Comments

1 OME661 Stone Guards are recommended fitment to vehicles driven on dirt roads to prevent stone damage to the shock absorbers.

2 N147S fits RHS, N148S fits LHS. No top mounting bushes supplied, re-use OE bushes.

3 When remaining stock of N148S and 2602 is exhausted no further product will be available.

FRONT <i>Estimated Lift: 30mm</i>	ALL MODELS	
	PART NUMBER	QTY
SPRING:	2791	1
NITROCHARGER	-	
TRIM PACKER	OMELNF10	EA

REAR <i>Estimated Lift: 30mm</i>	ALL MODELS	
	PART NUMBER	QTY
SPRING: MEDIUM LOAD	2792	1
NITROCHARGER	-	

FRONT SELECTION - Estimated Lift 50mm

PETROL & DIESEL ENGINES		Part Number	Qty	Notes
No Bar	Spring	2744	1	
	Strut - N/Sport	USE OE		1
Bar/ Winch	Spring	2745	1	
	Strut - N/Sport	USE OE		1

Comments

1 Coils are suitable to be used with original OE struts, OME will not be developing replacement struts.

REAR SELECTION - Estimated Lift 50mm

ALL MODELS		Part Number	Qty	Note
Medium Load	Spring	2746	1	
	Strut - N/Sport	USE OE		1
Constant 200kg	Spring	2743	1	
	Strut - N/Sport	USE OE		1

FRONT SELECTION

PETROL & DIESEL ENGINES			Part Number	Qty	Notes
Estimated Lift 40mm	No Bar	Spring	2776	1	1
		Shock - N/Sport	60024	2	
		Shock - N/Plus	63024		
	Bar Only	Spring	2777	1	1
		Shock - N/Sport	60024	2	
		Shock - N/Plus	63024		
	Bar/ Winch/ Accessories	Spring	2779	1	1
		Shock - N/Sport	60024	2	
		Shock - N/Plus	63024		

Comments

1 On 2003 Models lift will be between 25 to 35mm.

2 8mm Steel Coil Seat Packer, refer to fitting instructions supplied with packer.

Important: To prevent possible over stressing of the spring, only one packer can be fitted under each coil seat.

FIT KITS & HARDWARE

Loc	Description	Part Number	Qty	Note
F	STEERING DAMPER	OMESD02	1	
F	COIL PACKER	OMELRCP2	EA	2

REAR SELECTION

ALL MODELS			Part Number	Qty	Note
Estimated Lift 40mm	Medium Load	Spring	2781	1	
		Shock - N/Sport	60026	2	
		Shock - N/Plus	63026		
	Constant 100kg	Spring	2762	1	
		Shock - N/Sport	60025	2	
		Shock - N/Plus	63025		
	Constant 200kg	Spring	2763	1	
		Shock - N/Sport	60025	2	
		Shock - N/Plus	63025		

FIT KITS & HARDWARE

Loc	Description	Part Number	Qty	Note
R	COIL PACKER	OMELRCP1	EA	2

FRONT SELECTION

PETROL ENGINE		Part Number	Qty	Notes	
Estimated Lift 40mm	No Bar	Spring	2760	1	3
		Shock - N/Sport	60037	2	
		Shock - N/Plus	63037		
	Bar Only	Spring	2761	1	3
		Shock - N/Sport	60037	2	
		Shock - N/Plus	63037		
	Bar/ Winch/ Accessories	Spring	2767	1	3
		Shock - N/Sport	60037	2	
		Shock - N/Plus	63037		

Comments

- CALR1 : Fits pre '86 Range Rover.
CALR2 : Fits post '86 Range Rover, all Discovery & Defender 130 Dual Cab Utility.

NB: Do not fit to automatic Range Rovers or Discovery due to possible vibration problems.

- 8mm Steel Coil Seat Packer, refer to fitting instructions supplied with packer.

Important: To prevent possible over stressing of the spring, only one packer can be fitted under each coil seat.

- Not suitable for Models with air suspension.

- For High Articulation (HA) vehicles it is recommended to replace rear upper shock mount with FK64 and matching long shocks 60146 or 60147.

DIESEL ENGINE		Part Number	Qty	Notes	
Estimated Lift 40mm	Bar Only	Spring	2751	1	3
		Shock - N/Sport	60037	2	
		Shock - N/Plus	63037		
	Bar/ Winch/ Accessories	Spring	2767	1	3
		Shock - N/Sport	60037	2	
		Shock - N/Plus	63037		

FIT KITS & HARDWARE

Loc	Description	Part Number	Qty	Note
F	STEERING DAMPER	OMESD11		
F	CASTER KIT	CALR1	1	1
		CALR2		
F	COIL PACKER	OMELRCP1	EA	2

REAR SELECTION

ALL MODELS		Part Number	Qty	Note	
Estimated Lift 40mm	Medium Load	Spring	2764	1	3
		Shock - N/Sport	60038	2	4
		Shock - N/S HA	60146		
		Shock - N/Plus	63038		
		Shock - N/Plus HA	63146		
	Constant 100kg	Spring	2762	1	3
		Shock - N/Sport	60039	2	4
		Shock - N/S HA	60147		
		Shock - N/Plus	63039		
		Shock - N/Plus HA	63147		
	Constant 200kg	Spring	2763	1	3
		Shock - N/Sport	60039	2	4
		Shock - N/S Long	60147		
		Shock - N/Plus	63039		
		Shock - N/Plus HA	63147		

FIT KITS & HARDWARE

Loc	Description	Part Number	Qty	Note
R	COIL PACKER	OMELRCP1	EA	2
R	UPPER SHOCK MOUNT KIT	FK64	1	4

FRONT SELECTION⁶ - Estimated Lift 30-40mm

V8 PETROL ENGINE		Part Number	Qty	Notes
Bar Only	Spring	2761	1	1
	Shock - N/Sport	60037	2	6
	Shock - N/Plus	63037		
Bar/ Winch/ Accessories	Spring	2751	1	1
	Shock - N/Sport	60037	2	6
	Shock - N/Plus	63037		

3.9 ISUZU DIESEL ENGINE		Part Number	Qty	Notes
Bar Only	Spring	2766	1	1
	Shock - N/Sport	60037	2	6
	Shock - N/Plus	63037		
Bar/ Winch/ Accessories	Spring	2766	1	1
	Shock - N/Sport	60037	2	6
	Shock - N/Plus	63037		

2.5L DIESEL ENGINE		Part Number	Qty	Notes
Bar Only	Spring	2751	1	1
	Shock - N/Sport	60037	2	6
	Shock - N/Plus	63037		
Bar/ Winch/ Accessories	Spring	2767	1	1
	Shock - N/Sport	60037	2	6
	Shock - N/Plus	63037		

FIT KITS & HARDWARE

Loc	Description	Part Number	Qty	Note
F	STEERING DAMPER	OMESD32		
F	CASTER KIT	CALR1	1	1
		CALR2		
F	COIL PACKER	OMELRCP1	EA	4

REAR SELECTION

ALL MODELS		Part Number	Qty	Note	
Estimated Lift 55mm	Medium Load	Spring	2752	1	2
		Shock - N/Sport	60038	2	5,6
		Shock - N/S HA	60146		
		Shock - N/Plus	63038		
		Shock - N/Plus HA	63146	2	
	Constant 300kg	Spring	2755	1	
		Shock - N/Sport	60039	2	5,6
		Shock - N/S Long	60147		
		Shock - N/Plus	63039		
		Shock - N/Plus HA	63147	2	
	Constant 500kg	Spring	2754	1	3
		Shock - N/Sport	60039	2	5,6
Shock - N/S Long		60147			
Shock - N/Plus		63039			
	Shock - N/Plus HA	63147	2		

FIT KITS & HARDWARE

Loc	Description	Part Number	Qty	Note
R	COIL PACKER	OMELRCP3	EA	4
R	REAR UPPER SHOCK MOUNT	FK64	1	5

Comments

1 Caution: Due to altered gearbox mounts on Models after 1998 any lift above OE ride height may cause front driveline vibration that can only be rectified by fitment of front double cardan joints.

Caster Kit will increase caster angle by 2 degrees. Check manufacturer's specifications to determine if Caster Kit is required.

CALR1 suits 38mm wide control arms. CALR2 suits 44mm wide control arms.

2 2752 coil has a softer spring than OE coil. This is to provide improved ride quality with light loads only. Expect an estimated 25mm of lift.

OE springs are designated as medium load springs.

3 Original inner helper coil, where fitted, must be re-installed with OME Coils.

4 8mm Steel Coil Seat Packer, refer to selection chart supplied with packer.

Important: To prevent possible over stressing of the spring, only one packer can be fitted under each coil seat.

5 For High Articulation (HA) vehicles it is recommended to replace rear upper shock mount with FK64 and matching long shocks 60146 or 60147.

6 When remaining stock of 60037, 60038, 60039, 60146, 60147 and N45F is exhausted no further product will be available.

FRONT SELECTION - Estimated Lift 50mm

DIESEL ENGINE		Part Number	Qty	Notes
No Bar	Spring	3062	1	1,2
	Shock - N/Sport	60018	2	2
	Shock - N/Plus	63018		
Bar/ Winch/ Accessories	Spring	3063	1	1,2
	Shock - N/Sport	*60070 / 60018	2	2
	Shock - N/Plus	*63070 / 63018		

Comments

Caution: Front driveshaft **MUST** be replaced / modified with Double Cardan Joints and checked for Uni bind with OME shocks installed at droop. FK62, FK63, FK64 are **mandatory** fitment also.

1 When fitting coil springs recommended, it is **mandatory** to use 60018/60070 shock absorbers to achieve minimum down travel requirement.

2 When fitting 60018 / 60070 the following are **mandatory** requirements:

- * Fit longer coils 3062-3066 for springs to remain trapped with shocks fully extended
- * Fit FK62 to prevent shock damage
- * Fit FK63 for front driveshaft clearance and rear extended travel
- * Fit FK64 which replaces OE upper shock mount when fitting rear shocks
- * Remove any inner helper coils already fitted

3 Caster Kit will increase caster angle by 2 degrees. Check manufacturer's specifications to determine if Caster Kit is required. CALR1 suits 38mm wide control arms. CALR2 suits 44mm wide control arms.

4 8mm Steel Coil Seat Packer, refer to selection chart supplied with packer.

Important: To prevent possible over stressing of the spring, only one packer can be fitted under each coil seat.

5 Important: 3064 has reduced spring rate from OE to provide improved ride quality for light loads.

OE springs are designated as medium load springs.

6 Trailing Arm Bush is an optional fit. Bush kit is offset and accommodates for the increased angle of the trailing arm due to longer travel.

FIT KITS & HARDWARE

Loc	Description	Part Number	Qty	Note
F	STEERING DAMPER	OMESD32	1	3
F	CASTER KIT	CALR1		
		CALR2		
F	COIL PACKER	OMELRCP1	EA	4
F/R	BUMP SPACER KIT	FK62	1	2
F/R	SWAY BAR SPACER KIT	FK63		

REAR SELECTION

ALL MODELS		Part Number	Qty	Note	
Estimated Lift 50mm	Medium Load	Spring	3064	1	1,2,5
		Shock - N/Sport	60018	2	2
		Shock - N/Plus	63018		
	Constant 300kg	Spring	3065	1	1,2
		Shock - N/Sport	*60070 / 60018	2	2
		Shock - N/Plus	*63070 / 63018		
	Constant 500kg	Spring	3066	1	1,2
		Shock - N/Sport	60070	2	2
		Shock - N/Plus	63070		

FIT KITS & HARDWARE

Loc	Description	Part Number	Qty	Note
R	COIL PACKER	OMELRCP3	EA	4
R	REAR UPPER SHOCK MOUNT	FK64	1	6
R	BUSH KIT T/ARM OFFSET 16MM	OMESB0068		
R	BUSH KIT T/ARM OFFSET 20MM	OMESB0069		
F/R	BUMP SPACER KIT	FK62	1	2
F/R	SWAY BAR SPACER KIT	FK63		

FRONT SELECTION

2.5L DIESEL ENGINE		Part Number	Qty	Notes
Est Lift 50mm	No Bar	Spring	3062	1 1
		BP-51 Shock	BP5160035	2 2
		BP-51 Fit Kit	VM80010036	1
	Bar/ Winch/ Accessories	Spring	3063	1 1
		BP-51 Shock	BP5160045	2 2
		BP-51 Fit Kit	VM80010036	1

Comments

Caution: Front driveshaft **MUST** be replaced / modified with Double Cardan Joints and checked for Uni bind with BP-51 shocks installed at droop.

1 When fitting coil springs it is **mandatory** to use BP-51 shock absorbers to achieve minimum down travel requirement.

2 When fitting BP-51 shock absorbers the following are **mandatory** requirements:

* Fit longer coils 3062-3066 for springs to remain trapped with shocks fully extended

* Remove any inner helper coils already fitted

3 Caster Kit will increase caster angle by 2 degrees. Check manufacturer's specifications to determine if Caster Kit is required. CALR1 suits 38mm wide control arms. CALR2 suits 44mm wide control arms.

4 8mm Steel Coil Seat Packer, refer to selection chart supplied with packer.

Important: To prevent possible over stressing of the spring, only one packer can be fitted under each coil seat.

5 Important: 3064 has reduced spring rate from OE to provide improved ride quality for light loads.

OE springs are designated as medium load springs.

6 Trailing Arm Bush is an optional fit. Bush kit is offset and accommodates for the increased angle of the trailing arm due to longer travel.

FIT KITS & HARDWARE

Loc	Description	Part Number	Qty	Note
F	STEERING DAMPER	OMESD32		
F	CASTER KIT	CALR1	1	3
		CALR2		
F	COIL PACKER	OMELRCP1	EA	4

REAR SELECTION

ALL MODELS		Part Number	Qty	Note
Estimated Lift 50mm	Medium Load	Spring	3064	1 1,2,5
		BP-51 Shock	BP5160036	2 2
		BP-51 Fit Kit	VM80010037	1
	Constant 300kg	Spring	3065	1 1,2
		BP-51 Shock	BP5160036	2 2
		BP-51 Fit Kit	VM80010037	1
	Constant 500kg	Spring	3066	1 1,2
		BP-51 Shock	BP5160036	2 2
		BP-51 Fit Kit	VM80010037	1

FIT KITS & HARDWARE

Loc	Description	Part Number	Qty	Note
R	COIL PACKER	OMELRCP3	EA	4
R	BUSH KIT T/ARM OFFSET 16MM	OMESB0068		
R	BUSH KIT T/ARM OFFSET 20MM	OMESB0069	1	6

FRONT SELECTION - Estimated lift 20mm

DIESEL ENGINE		Part Number	Qty	Notes
Bar Only	Spring	2751	1	
	Shock - N/Sport	60037	2	
	Shock - N/Plus	63037		
Bar/ Winch/ Accessories	Spring	2767	1	
	Shock - N/Sport	60037	2	
	Shock - N/Plus	63037		

FIT KITS & HARDWARE

Loc	Description	Part Number	Qty	Note
F	STEERING DAMPER	OMESD32		
F	CASTER KIT	CALR1	1	1
		CALR2		
F	COIL PACKER	OMELRCP1	EA	3

REAR SELECTION

ALL MODELS		Part Number	Qty	Note	
Estimated Lift 40mm	Medium Load	Spring	2755	1	2
		Shock - N/Sport	60039	2	5
		Shock - N/S HA	60147		
		Shock - N/Plus	63039		
	Shock - N/Plus HA	63147			
	Constant 300kg	Spring	2754	1	4
		Shock - N/Sport	60039	2	5
		Shock - N/S HA	60147		
		Shock - N/Plus	63039		
	Shock - N/Plus HA	63147			
	Constant 500kg	Spring	2754	1	3
		Shock - N/Sport	60039	2	5
Shock - N/S HA		60147			
Shock - N/Plus		63039			
Shock - N/Plus HA	63147				

FIT KITS & HARDWARE

Loc	Description	Part Number	Qty	Note
R	COIL PACKER	OMELRCP3	EA	3
R	REAR UPPER SHOCK MOUNT	FK64	1	5

Comments

1 Caution: Due to altered gearbox mounts on Models after 1998 any lift above OE ride height will cause front driveline vibration that can only be rectified by fitment of front double cardan joints.

Caster Kit will increase caster angle by 2 degrees. Check manufacturer's specifications to determine if Caster Kit is required. CALR1 suits 38mm wide control arms. CALR2 suits 44mm wide control arms.

2 Important: 2755 has reduced spring rate from OE to provide improved ride quality for light loads. Expect an estimated 25mm of lift. Original inner helper coil, where fitted, **must** be re-installed with OME Coils.

3 8mm Steel Coil Seat Packer, refer to selection chart supplied with packer.

Important: To prevent possible overstressing of the spring, only one packer can be fitted under each coil seat.

4 Original inner helper coil, where fitted, must be re-installed with OME Coils.

5 For High Articulation (HA) vehicles it is recommended to replace rear upper shock mount with FK64 and matching long shocks 60147.

FRONT SELECTION - Estimated Lift 30mm

PETROL ENGINE		Part Number	Qty	Notes
Bar Only	Spring	2761	1	1
	Shock - N/Sport	60037	2	
	Shock - N/Plus	63037		
Bar/ Winch/ Accessories	Spring	2751	1	1
	Shock - N/Sport	60037	2	
	Shock - N/Plus	63037		

DIESEL ENGINE		Part Number	Qty	Notes
Bar Only	Spring	2751	1	1
	Shock - N/Sport	60037	2	
	Shock - N/Plus	63037		
Bar/ Winch/ Accessories	Spring	2767	1	1
	Shock - N/Sport	60037	2	
	Shock - N/Plus	63037		

Comments

1 Caution: Due to altered gearbox mounts on Models after 1998 any lift above OE ride height will cause front driveline vibration that can only be rectified by fitment of front Double Cardan joints.

2 Caster Kit will increase caster angle by 2 degrees. Check manufacturer's specifications to determine if Caster Kit is required. CALR1 suits 38mm wide control arms. CALR2 suits 44mm wide control arms.

3 For high articulation vehicles it is recommended to replace rear upper shock mount with FK64 and matching long shocks 60146 or 60147.

FIT KITS & HARDWARE

Loc	Description	Part Number	Qty	Note
F	STEERING DAMPER	OMESD32		
F	CASTER KIT	CALR1	1	2
F		CALR2		

REAR SELECTION

ALL MODELS		Part Number	Qty	Note	
Est Lift 45-55mm	Medium Load	Spring	2764	1	1
		Shock - N/Sport	60038	2	2,3
		Shock - N/S HA	60146		
		Shock - N/Plus	63038		
		Shock - N/Plus HA	63146		
	Constant 200kg	Spring	2762	1	1
		Shock - N/Sport	60039	2	2,3
		Shock - N/S HA	60147		
		Shock - N/Plus	63039		
		Shock - N/Plus HA	63147		

FIT KITS & HARDWARE

Loc	Description	Part Number	Qty	Note
R	REAR UPPER SHOCK MOUNT	FK64	1	3

FRONT SELECTION^b

3.0 DIESEL ENGINE		Part Number	Qty	Notes
Estimated Lift 40mm	No Bar	Spring	2883	1
		Strut - N/Sport	90045	2 1
	Bar Only	Spring	3114	1
		Strut - N/Sport	*90046 / 90045	2 1
	Bar/ Winch	Spring	2884	1
		Strut - N/Sport	90046	2 1
Bar/ Winch/ Accessories	Spring	2885	1	
	Strut - N/Sport	90046	2 1	
Nitro +	Spring	4001	1	
	Strut	*93046 / 93045	2 1,10	
BP-51	Coilover LH	BP5190014L	1	
	Coilover RH	BP5190014R		
	Fit Kit	VM80010044		

Comments

- 1 No top mounting bushes supplied use OME3134. OE bushes may be re-used if in good condition. OME struts can only be installed with OME coils.
- 2 OMESB119 Bush Kit suits OME Greasable Shackle, OMEGS26. OMESB120 Bush Kit suits OE Shackle.
- 3 If fitting extra leaf to EL125R, use U Bolt OMEU53B.
- 4 Handbrake Cable Fit Kit FK66 is required fitment.
- 5 Strut Top Hat Kit may be required if original equipment is worn.

FIT KITS & HARDWARE

Loc	Description	Part Number	Qty	Note
F	TRIM PACKER	OME95PF5		
F	UPPER STRUT BUSHES	OME3134		1
F	STRUT TOP HAT KIT	OMETH004	EA	5
F	FRONT AXLE UPGRADE LABEL KIT	FAUBT1595		7
F	UPPER CONTROL ARM	UCA0007		9

- 6 LS-M Ute & SX XT Cab Chassis models are fitted with heavy duty leaf springs. Lift results may vary.
- 7 Australia Only. Full OME suspension system must be fitted.
- 8 Refer to **Leaf Spring Service Parts** section for Centre Bolt selection.

REAR SELECTION

ALL MODELS		Part Number	Qty	Notes	
Estimated Lift 40mm	Medium Load	Spring Multi leaf	EL123R	2	
		Shock - N/Sport	60167		
		Shock - N/Plus	63167		
	Constant 300kg	Spring Multi leaf	EL124R	2	
		Shock - N/Sport	*60168 / 60167		
		Shock - N/Plus	*63168 / 63167		
	Constant 600kg	Spring Multi leaf	EL125R	2	3
		Shock - N/Sport	60168		
		Shock - N/Plus	63168		
	BP-51	Shock Rear	BP5160050	2	
		Fit Kit	VM80010045	1	
	SPRING BUSH KIT		OMESB119	2	2
	U BOLTS		OMEU53A	4	3
			OMEU53B		
GREASABLE SHACKLE KIT		OMEGS26			
GREASABLE PIN KIT		OMEGP9	1		
HANBRAKE RELOCATION KIT		FK66		4	

- 9 Does not use a ball joint cover.
- 10 Does not suit OE Coil.

FIT KITS & HARDWARE

Loc	Description	Part Number	Qty	Note
R	EXTRA LEAF	EL39XL	2	3
R	EXTRA LEAF SPACER KIT	ELSK12		
R	TRIM PACKER	ELSK05	EA	
R	CENTRE BOLT			8

FRONT SELECTION

DIESEL ENGINE		Part Number	Qty	Notes
Est Lift 50mm	No Bar	Spring	2997	1 4
		Strut - N/Sport	90019	2 1,12
	Bar Only	Spring	2998	1 4
		Strut - N/Sport	*90020 / 90019	2 1,12
Bar/ Winch/ Accessories	Spring	2999	1 4	
	Strut - N/Sport	90020	2 1,12	
Nitro +	Spring	4013	1 4	
	Strut	*93020 / 93019	2 1,13	
30mm	No Bar	Spring	3048	1 4
		Strut - N/Sport	90019	2 1,12
Nitro +	Spring	4025	1 4	
	Strut	93019	2 1	
30-40mm	BP-51	Coilover LH	BP5190005L	1+1
		Coilover RH	BP5190005R	
		Fit Kit	VM80010011	1

FIT KITS & HARDWARE

Loc	Description	Part Number	Qty	Note
F	UPPER CONTROL ARM	UCA0002	1	5
F	TRIM PACKER	FK56	EA	2
F	UPPER STRUT BUSHES	OME3135	2	1
F	STRUT TOP HAT KIT	OMETH006		3

SERVICE PARTS

Description	Part Number	Qty	Note
OME UCA Eye Bush 2pk	UCASP004	1	
OME UCA Ball Joint 1pk	UCASP005	EA	
OME UCA Boot 2pk	UCASP006	1	

Comments

- 1 No top mounting bushes supplied use OME3135. OE bushes may be re-used if in good condition.
- 2 Trim Packer FK56 provides 10mm lift at the wheel.
- 3 Strut Top Hat Kit may be required if original equipment is worn.
- 4 **Important:** Please refer to TSB003.
- 5 The OME Upper Control Arm will provide an increase between +2.5 and +3.5 degrees of caster and up to 1.5 degrees of negative camber increase (figures based off an approximate 50mm lift). Please note after fitment of Upper Control Arm a vehicle wheel alignment will be required.
- 6 OMESB117 suits OE Shackle & Greasable Shackle Pin Kit OMEGP10 - ¹²EL102R/¹²EL103R/EL126R/EL127R/ EL128R.

OMESB102 suits OE Shackle & Greasable Shackle Pin Kit OMEGP9 - EL049R.

OMESB118 Bush Kit suits OME Greasable Shackle OMEGS20 - ¹²EL102R/¹²EL103R/ EL126R/ EL127R/ EL128R.

OMESB103 suits OME Greasable Shackle OMEGS20 - EL049R.
- 7 Use OMEU66 when fitting ¹²EL102R/ EL126R.

Use OMEU66A when fitting ¹²EL103R/ EL127R/ EL128R.

Use OMEU66B when fitting EL128R with EL34XL.
- 8 Fitment of Driveline Spacer Kit FK57 is recommended to re-align driveline.
- 9 EL34XL will give approximately 30mm extra lift or increase loading capacity at design height by approximately 300kg.
- 10 If a TAD110 Frontier tank is installed in the vehicle, when fitting the FK57 spacer kit, the tank will need to be lowered to allow removal of the centre bearing bolts.
- 11 Refer to **Leaf Spring Service Parts** section for Centre Bolt selection.
- 12 When remaining stock of 90019, 90020, EL102R and EL103R is exhausted no further product will be available.
- 13 Does not suit OE Coil.

REAR SELECTION

ALL MODELS		Part Number	Qty	Notes	
Estimated Lift 40mm	Medium Load	Spring Multi leaf	EL126R	4,7	
		Shock - N/Sport	*60101 / 60023	2	
		Shock - N/Plus	*63101 / 63023		
	Constant 300kg	Spring Multi leaf	EL127R	4,7	
		Shock - N/Sport	*60102 / 60101	2	
		Shock - N/Plus	*63102 / 63101		
	Constant 600kg	Spring Multi leaf	EL128R	4,7	
		Shock - N/Sport	60102	2	
		Shock - N/Plus	63102		
	BP-51	Shock - LH	BP5160027L	1+1	
		Shock - RH	BP5160027R		
		Shock - LH	*BP5160037L	1+1	
		Shock - RH	*BP5160037R		
		Fit Kit	VM80010012	1	
	GREASABLE SHACKLE KIT		OMEGS20		
	GREASABLE PIN KIT		OMEGP10	1	
			OMEGP9		
	SPRING BUSH KIT		OMESB117	2	6
		OMESB118			
		OMESB102			
		OMESB103			
U BOLTS		OMEU66	4	7	
		OMEU66A			
		OMEU66B			
DRIVELINE SPACER KIT		FK57	1	8,10	

FIT KITS & HARDWARE

Loc	Description	Part Number	Qty	Notes
R	EXTRA LEAF	EL34XL	2	9
R	EXTRA LEAF SPACER KIT	ELSK05		
R	TRIM PACKER	ELSK12	EA	
R	CENTRE BOLT			11

Comments

1 No top mounting bushes supplied use OME3135. OE bushes may be re-used if in good condition.

2 Trim Packer FK56 provides 10mm lift at the wheel.

3 Strut Top Hat Kit may be required if original equipment is worn.

4 **Important:** Please refer to TSB003.

5 The OME Upper Control Arm will provide an increase between +2.5 and +3.5 degrees of caster and up to 1.5 degrees of negative camber increase (figures based off an approximate 50mm lift). Please note after fitment of Upper Control Arm a vehicle wheel alignment will be required.

6 OMESB117 suits OE Shackle & Greasable Shackle Pin Kit OMEGP10 - ¹²EL102R/¹²EL103R/EL126R/EL127R/ EL128R.

OMESB102 suits OE Shackle & Greasable Shackle Pin Kit OMEGP9 - EL049R.

OMESB118 Bush Kit suits OME Greasable Shackle OMEGS20 - ¹²EL102R/¹²EL103R/ EL126R/ EL127R/ EL128R.

OMESB103 suits OME Greasable Shackle OMEGS20 - EL049R.

7 Use OMEU66 when fitting ¹²EL102R/ EL126R.

Use OMEU66A when fitting ¹²EL103R/ EL127R/ EL128R.

Use OMEU66B when fitting EL128R with EL34XL.

8 Fitment of Driveline Spacer Kit FK57 is recommended to re-align driveline.

9 EL34XL will give approximately 30mm extra lift or increase loading capacity at design height by approximately 300kg.

10 If a TAD110 Frontier tank is installed in the vehicle, when fitting the FK57 spacer kit, the tank will need to be lowered to allow removal of the centre bearing bolts.

11 Refer to **Leaf Spring Service Parts** section for Centre Bolt selection.

12 When remaining stock of 60023, 60101, 60102, EL102R and EL103R is exhausted no further product will be available.

FRONT SELECTION⁵ - Estimated Lift 40mm

PETROL & DIESEL ENGINES		Part Number	Qty	Notes
Bar/ Winch/ Accessories	Torsion Bars	303013	1	
	Shock - N/Sport	60022	2	1
	Shock - N/Plus	63022		1

FIT KITS & HARDWARE

Loc	Description	Part Number	Qty	Note
F	FITTING KIT	FK22	1	1

REAR SELECTION

ALL MODELS		Part Number	Qty	Note	
Estimated Lift 20mm	Medium Load	Leaf Spring	CS056R	2,3	
		Shock - N/Sport	60023	2	
		Shock - N/Plus	63023		
	Constant 200kg	Leaf Spring	EL049R	2,3	
		Shock - N/Sport	60023	2	
		Shock - N/Plus	63023		
	Constant 400kg	Leaf Spring	CS060R	2,3	
		Shock - N/Sport	*60102 / 60023	2	
		Shock - N/Plus	*63102 / 63023		
		GREASABLE SHACKLE KIT	OMEGS18	1	
		GREASABLE PIN KIT	OMEGP14		
		U BOLTS	OMEU66	4	2
	OMEU66A				
	SPRING BUSH KIT	OMESB97	2		

FIT KITS & HARDWARE

Loc	Description	Part Number	Qty	Note
R	EXTRA LEAF	EL34XL	2	3
		D34XL		
R	CENTRE BOLT			3,4

Comments

1 FK22 Front Shock Absorber Upper Mount Support Bracket Kit is a **mandatory** fitment.

2 Include tray weight in constant load calculation. Use OMEU66 when fitting CS056R and EL049R. Use OMEU66A when fitting CS060R.

3 D34XL and UCB19 suits CS056R and CS060R. EL34XL suits EL049R.

4 Refer to **Leaf Spring Service Parts** section for Centre Bolt selection.

5 When remaining stock of 60023, 60102, N187 and N194 is exhausted no further product will be available.

FRONT SELECTION⁴

Petrol & Diesel Engine		Part Number	Qty	Notes
Bar/ Winch/ Accessories	Torsion Bars	303005	1	
	Shock - N/Sport	60022	2	1
	Shock - N/Plus	63022		

FIT KITS & HARDWARE

Loc	Description	Part Number	Qty	Note
F	FITTING KIT	FK22	1	1

REAR SELECTION

ALL MODELS		Part Number	Qty	Note	
Estimated Lift 20mm	Medium Load	Leaf Spring	CS026R	2	
		Shock - N/Sport	60023	2	
		Shock - N/Plus	63023		
	Constant 200kg	Leaf Spring	CS027R	2	
		Shock - N/Sport	60023	2	
		Shock - N/Plus	63023		
	U BOLTS		OMEU65	4	
	GREASABLE SHACKLE KIT		OMEGS18	1	
	SPRING BUSH KIT		OMESB82	2	

FIT KITS & HARDWARE

Loc	Description	Part Number	Qty	Note
R	EXTRA LEAF	D9XL	2	
R	CENTRE BOLT		EA	3

Comments

1 FK22 Front Shock Absorber Upper Mount Support Bracket Kit is a **mandatory** fitment.

2 Include tray weight in constant load calculation.

3 Refer to **Leaf Spring Service Parts** section for Centre Bolt selection.

4 When remaining stock of 60023 and N51 is exhausted no further product will be available.

FRONT SELECTION - Estimated Lift 50mm

ALL MODELS		Part Number	Qty	Notes
No Bar	Spring	3028	1	
	Shock - N/Sport	60113	2	
Bar/ Winch	Spring	3029	1	
	Shock - N/Sport	60113	2	

REAR SELECTION - Estimated Lift 50mm

ALL MODELS		Part Number	Qty	Note
Medium Load	Spring	3030	1	
	Shock - N/Sport	60114	2	

FRONT SELECTION

DIESEL ENGINE		Part Number	Qty	Notes	
Estimated Lift 20mm	No Bar	Spring	2605	1	1
		Strut - N/Sport	90008	2	3
		Strut - N/Plus	93008		
	Bar Only	Spring	2606	1	1
		Strut - N/Sport	90008	2	3
		Strut - N/Plus	93008		
	Bar/ Winch/ Accessories	Spring	3132	1	1
		Strut - N/Sport	90008	2	3
		Strut - N/Plus	93008		

Comments

- 1** No top mounting bushes supplied use OME3121. OE bushes may be re-used if in good condition.
- 2** Strut Top Hat Kit may be required if original equipment is worn.
- 3** Does not suit OE Coil

FIT KITS & HARDWARE

Loc	Description	Part Number	Qty	Note
F	UPPER STRUT BUSHES	OME3121	2	1
F	STRUT TOP HAT KIT	OMETH001		2

REAR SELECTION

ALL MODELS		Part Number	Qty	Note	
Estimated Lift 35mm	Medium Load	Spring	2910	1	
		Shock - N/Sport	60076	2	2
		Shock - N/Plus	63076		
	Constant 200kg	Spring	2938	1	
		Shock - N/Sport	*60075 / 60076	2	2
		Shock - N/Plus	*63075 / 63076		
	Constant 400kg	Spring	2838	1	
		Shock - N/Sport	60075	2	2
		Shock - N/Plus	63075		

FRONT SELECTION

V6 PETROL ENGINE		Part Number	Qty	Notes	
Estimated Lift 30-40mm	No Bar	Spring	3108	1	1
		Strut - N/Sport	90006	2	4
		Strut - N/Plus	93006		
	Bar Only	Spring	2914	1	1
		Strut - N/Sport	*90007 / 90006	2	4
		Strut - N/Plus	*93007 / 93006		
	Bar/ Winch/ Accessories	Spring	3109	1	1
		Strut - N/Sport	90007	2	4
		Strut - N/Plus	93007		

Comments

- 1 It is recommended that a 4 wheel alignment is carried out.
- 2 No top mounting bushes supplied use OME3101. OE bushes can be re-used if in good condition.
- 3 Strut Top Hat Kit may be required if original equipment is worn.
- 4 Does not suit OE Coil

FRONT SELECTION

2.8 & 3.2 DIESEL ENGINES		Part Number	Qty	Notes	
Est Lift 30-40mm	No Bar	Spring	2914	1	
		Strut - N/Sport	90006	2	2,4
		Strut - N/Plus	93006		
	Bar Only	Spring	3109	1	
		Strut - N/Sport	*90007 / 90006	2	2,4
		Strut - N/Plus	*93007 / 93006		
	Bar/ Winch/ Accessories	Spring	2915	1	
		Strut - N/Sport	90007	2	2,4
		Strut - N/Plus	93007		

FIT KITS & HARDWARE

Loc	Description	Part Number	Qty	Note
F	UPPER STRUT BUSHES	OME3101	2	2
F	STRUT TOP HAT KIT	OMETH007		3

REAR SELECTION

ALL MODELS		Part Number	Qty	Note	
Estimated Lift 40-50mm	Medium Load	Spring	3110	1	1
		Shock - N/Sport	60019	2	
		Shock - N/Plus	63019		
	Constant 200kg	Spring	3111	1	1
		Shock - N/Sport	60033	2	
		Shock - N/Plus	63033		
	Constant 400kg	Spring	3112	1	1
		Shock - N/Sport	60033	2	
		Shock - N/Plus	63033		

FRONT SELECTION - Estimated Lift 35mm

V6 PETROL ENGINE		Part Number	Qty	Notes
Bar Only	Spring	2914	1	
	Strut - N/Sport	90006	2	2
	Strut - N/Plus	93006		2,4
Bar/ Winch/ Accessories	Spring	2915	1	
	Strut - N/Sport	90007	2	2
	Strut - N/Plus	93007		2,4

FRONT SELECTION - Estimated Lift 35mm

2.8 & 3.2 DIESEL ENGINES		Part Number	Qty	Notes
Bar Only	Spring	2915	1	
	Strut - N/Sport	90006	2	2
	Strut - N/Plus	93006		2,4
Bar/ Winch/ Accessories	Spring	2924	1	
	Strut - N/Sport	90007	2	2
	Strut - N/Plus	93007		2,4

FIT KITS & HARDWARE

Loc	Description	Part Number	Qty	Note
F	UPPER STRUT BUSHES	OME3101	2	2
F	STRUT TOP HAT KIT	OMETH007		3

REAR SELECTION

ALL MODELS		Part Number	Qty	Note	
Est Lift 40mm	Medium Load	Spring	2917	1	1
		Shock - N/Sport	60019	2	
		Shock - N/Plus	63019		
	Constant 200kg	Spring	2918	1	1
		Shock - N/Sport	60033	2	
		Shock - N/Plus	63033		
	Constant 300kg	Spring	2995	1	1
		Shock - N/Sport	60033	2	
		Shock - N/Plus	63033		

Comments

- 1 It is recommended that a 4 wheel alignment is carried out.
- 2 No top mounting bushes supplied use OME3101. OE bushes can be re-used if in good condition.
- 3 Strut Top Hat Kit may be required if original equipment is worn.
- 4 Does not suit OE Coil.

FRONT SELECTION - Estimated Lift 35mm

V6 PETROL ENGINE		Part Number	Qty	Notes
Bar Only	Spring	2914	1	
	Strut - N/Sport	90006	2	2
	Strut - N/Plus	93006		2,4
Bar/ Winch/ Accessories	Spring	2915	1	
	Strut - N/Sport	90007	2	2
	Strut - N/Plus	93007		2,4

Comments

- 1** It is recommended that a 4 wheel alignment is carried out.
- 2** No top mounting bushes supplied use OME3101. OE bushes can be re-used if in good condition.
- 3** Strut Top Hat Kit may be required if original equipment is worn.
- 4** Does not suit OE Coil.

FRONT SELECTION - Estimated Lift 35mm

3.2 DIESEL ENGINES		Part Number	Qty	Notes
Bar Only	Spring	2915	1	
	Strut - N/Sport	90006	2	2
	Strut - N/Plus	93006		2,4
Bar/ Winch/ Accessories	Spring	2924	1	
	Strut - N/Sport	90007	2	2
	Strut - N/Plus	93007		2,4

FIT KITS & HARDWARE

Loc	Description	Part Number	Qty	Note
F	UPPER STRUT BUSHES	OME3101	2	2
F	STRUT TOP HAT KIT	OMETH007		3

REAR SELECTION - Estimated Lift 40mm

ALL MODELS		Part Number	Qty	Note
Medium Load	Spring	2994	1	1
	Shock - N/Sport	60019	2	
	Shock - N/Plus	63019		
Constant 200kg	Spring	2917	1	1
	Shock - N/Sport	60033	2	
	Shock - N/Plus	63033		

FRONT SELECTION

ALL MODELS		Part Number	Qty	Notes
Bar/ Winch/ Accessories	Torsion Bars	303010	1	1
		303011		
	Shock - N/Sport	60040	2	

REAR SELECTION - Estimated Lift 45-50mm

ALL MODELS		Part Number	Qty	Notes
Medium Load	Leaf Spring	CS022R	2	2
	Shock - N/Sport	60057		
Constant 250kg	Leaf Spring	CS023R	2	2
	Shock - N/Sport	*60036 / 60057		
SPRING BUSH KIT		OMESB38	2	2
GREASABLE SHACKLE KIT		OMEGS16	1	

Comments

1 Raise or lower front end clearance and trim vehicle by adjusting front torsion bars.

Important: A minimum of 60mm of droop **must** be maintained.

303010 suits 88 To 90 V6 Models and all Models 91 To 94 - length 1278mm.

303011 suits all Models 95 To 00 - length 1308mm.

2 OMESB38 **must** be used to fit OME springs.

FRONT SELECTION²

ALL MODELS		Part Number	Qty	Notes
Bar/ Winch/ Accessories	Torsion Bars	303010	1	1
		303011		
	Shock - N/Sport	60040	2	
	Shock - N/Plus	63040		

Comments

1 Raise or lower front end clearance and trim vehicle by adjusting front torsion bars.

Important: A minimum of 60mm of droop **must** be maintained.

REAR SELECTION - Estimated Lift 20mm

ALL MODELS		Part Number	Qty	Notes
Medium Load	Spring	2910	1	
	Strut - N/Sport	60041	2	
	Strut - N/Plus	63041		
Constant 200kg	Spring	2938	1	
	Strut - N/Sport	60041	2	
	Strut - N/Plus	63041		

303010 suits all Models 91 To 94 with 1278mm length.

303011 suits all Models 95 To 00 with 1308mm length.

2 When remaining stock of N18 is exhausted no further product will be available.

FRONT SELECTION

ALL MODELS		Part Number	Qty	Notes
Bar/ Winch/ Accessories	Torsion Bars	-	1	1
	Shock - N/Sport	60040	2	
	Shock - N/Plus	63040		

Comments

1 Raise or lower front end clearance and trim vehicle by adjusting front torsion bars.

REAR SELECTION - Estimated Lift 20mm

ALL MODELS		Part Number	Qty	Notes
Medium Load	Spring	2911	1	
	Strut - N/Sport	60041	2	
	Strut - N/Plus	63041		

Important: A minimum of 60mm of droop **must** be maintained.

FRONT SELECTION

ALL MODELS		Part Number	Qty	Notes
Bar/ Winch/ Accessories	Torsion Bars	303010	1	1
	Shock - N/Sport	60051	2	

Comments

1 Raise or lower front end clearance and trim vehicle by adjusting front torsion bars.

REAR SELECTION - Estimated Lift 20mm

ALL MODELS		Part Number	Qty	Notes
Medium Load	Spring	2910	1	
	Strut - N/Sport	60056	2	

Important: A minimum of 60mm of droop **must** be maintained.

303010 suits 88 To 90 V6 Models.

FRONT SELECTION

4 CYLINDER ENGINE		Part Number	Qty	Notes
Bar/ Winch/ Accessories	Torsion Bars	303009	1	1
	Shock - N/Sport	60051	2	

REAR SELECTION

ALL MODELS		Part Number	Qty	Notes	
Est Lift 45-50mm	Medium Load	Leaf Spring	CS022R	1	2
		Shock - N/Sport	60057	2	
	Constant 250kg	Leaf Spring	CS023R	1	2
		Shock - N/Sport	*60036 / 60057	2	
	SPRING BUSH KIT		OMESB8	2	2
	U BOLT		OMEU54	4	3
	GREASABLE SHACKLE KIT		OMEGS16	1	

Comments

1 Raise or lower front end clearance and trim vehicle by adjusting front torsion bars.

Important: A minimum of 60mm of droop **must** be maintained.

303009 suits 82 To 90 4 cylinder Models - length 1278mm.

2 OMESB8 **must** be used with CS022R and CS023R springs.

3 OMEU54 only required on SWB Models.

FRONT SELECTION

V6 PETROL ENGINE		Part Number	Qty	Notes
Estimated Lift 20mm	No Bar	Spring	2611	1
		Strut - N/Sport	90008	2
		Strut - N/Plus	93008	2
	Bar Only	Spring	2605	1
		Strut - N/Sport	90008	2
		Strut - N/Plus	93008	2
	Bar/ Winch/ Accessories	Spring	2606	1
		Strut - N/Sport	90008	2
		Strut - N/Plus	93008	2

Comments

- 1 No top mounting bushes supplied use OME3121. OE bushes may be re-used if in good condition.
- 2 Strut Top Hat Kit may be required if original equipment is worn.
- 3 Does not suit OE Coil.

FRONT SELECTION

DIESEL ENGINE		Part Number	Qty	Notes
Estimated Lift 20mm	No Bar	Spring	2605	1
		Strut - N/Sport	90008	2
		Strut - N/Plus	93008	2
	Bar Only	Spring	2606	1
		Strut - N/Sport	90008	2
		Strut - N/Plus	93008	2
	Bar/ Winch/ Accessories	Spring	3132	1
		Strut - N/Sport	90008	2
		Strut - N/Plus	93008	2

FIT KITS & HARDWARE

Loc	Description	Part Number	Qty	Note
F	UPPER STRUT BUSHES	OME3121	2	1
F	STRUT TOP HAT KIT	OMETH001		2

REAR SELECTION

ALL MODELS		Part Number	Qty	Notes
Est Lift 35mm	Medium Load	Spring	2910	1
		Shock - N/Sport	60076	2
		Shock - N/Plus	63076	2
	Constant 300kg	Spring	2938	1
		Shock - N/Sport	*60075 / 60075	2
		Shock - N/Plus	*63075 / 63076	2
	Constant 600kg	Spring	2838	1
		Shock - N/Sport	60075	2
		Shock - N/Plus	63075	2

FRONT SELECTION

V6 PETROL ENGINE		Part Number	Qty	Notes
Bar/ Winch/ Accessories	Torsion Bars	303011	1	1
	Shock - N/Sport	60040	2	

Comments

1 Raise or lower front end clearance and trim vehicle by adjusting front torsion bars.

REAR SELECTION - Estimated Lift 40mm

ALL MODELS		Part Number	Qty	Notes
Medium Load	Spring	2911	1	
	Strut - N/Sport	60059	2	
Constant 200kg	Spring	2910	1	
	Strut - N/Sport	60059	2	

Important: A minimum of 60mm of droop **must** be maintained.

FRONT SELECTION

ALL MODELS		Part Number	Qty	Notes
Bar/ Winch/ Accessories	Torsion Bars	303011	1	1
	Shock - N/Sport	60040	2	

REAR SELECTION

ALL MODELS		Part Number	Qty	Notes	
Est Lift 25mm	Medium Load	Leaf Spring	CS040R	2	2,3
		Strut - N/Sport	60057		
	Constant 200kg	Leaf Spring	CS041R	2	2,3
		Strut - N/Sport	*60036 / 60057		
	SPRING BUSH KIT		OMESB83	2	3
	GREASABLE SHACKLE KIT		OMEGS16	1	2

FIT KITS & HARDWARE

Loc	Description	Part Number	Qty	Note
R	EXTRA LEAF	D7XL	2	
R	CENTRE BOLT			4

Comments

1 Raise or lower front end clearance and trim vehicle by adjusting front torsion bars.

Important: A minimum of 60mm of droop must be maintained.

303011 suits all Models with bar - length 1308mm.

2 OMEGS16 is a **mandatory** fitment to prevent springs from inverting.

3 OMESB83 is a **mandatory** fitment to OME springs only. The Centre Bolt on CS040R must be reversed prior to fitment. Springs can be only installed with OME Bush Kit.

4 Refer to **Leaf Spring Service Parts** section for Centre Bolt selection.

FRONT SELECTION

ALL MODELS		Part Number	Qty	Notes	
Estimated Lift 25mm	No Bar	Spring	3102	1	
		Strut - N/Sport	90031	2	1
		Strut - N/Plus	93031		1,8
	Bar Only	Spring	3103	1	
		Strut - N/Sport	90033	2	1
		Strut - N/Plus	93031		1,8
	Bar/ Winch	Spring	3104	1	
		Strut - N/Sport	90033	2	1
		Strut - N/Plus	93031		1,8
	Bar/ Winch/ Accessories	Spring	3105	1	
		Strut - N/Sport	90033	2	1
		Strut - N/Plus	93033		1,8

Comments

1 No top mounting bushes supplied use OME3121. OE bushes may be re-used if in good condition. No dirt shield supplied, please re-use OE.

2 Strut Top Hat Kit OMEMH001 may be required if original equipment is worn.

3 Shock absorber 60140/63140 is suited for constant rear loading in excess of 800kg.

4 OMESB113 suits OE Shackle and OME Greasable Shackle, OMEGS23.

5 EL44XL will give approximately 10mm extra lift or increase loading capacity at design height by approximately 200kgs.

6 Use OMEU53B when adding an EL44XL to EL118R / EL119R
OMEU53A suits all other applications

7 Refer to **Leaf Spring Service Parts** section for Centre Bolt selection.

8 Does not suit OE Coil.

FIT KITS & HARDWARE

Loc	Description	Part Number	Qty	Note
F	UPPER STRUT BUSHES	OME3121	2	
F	STRUT TOP HAT KIT	OMETH001		2

REAR SELECTION

ALL MODELS		Part Number	Qty	Notes	
Estimated Lift 20mm	Medium Load	Leaf Spring	EL117R		
		Shock - N/Sport	60138	2	
		Shock - N/Plus	63138		
	Constant 300kg	Leaf Spring	EL118R		
		Shock - N/Sport	*60139 / 60138	2	
		Shock - N/Plus	*63139 / 63138		
	Constant 600kg	Leaf Spring	EL119R		
		Shock - N/Sport	*60140 / 60139	2	3
		Shock - N/Plus	*63140 / 63139		
	GREASABLE SHACKLE KIT		OMEGS23	1	
	GREASABLE PIN KIT		OMEGP13		
	SPRING BUSH KIT		OMESB113	2	4
	U BOLT		OMEU53A	4	6
			OMEU53B		

FIT KITS & HARDWARE

Loc	Description	Part Number	Qty	Note
R	EXTRA LEAF	EL44XL	2	5,6
R	TRIM PACKER	ELSK05		
R	EXTRA LEAF SPACER KIT	ELSK12		
R	CENTRE BOLT		EA	7

FRONT SELECTION

DIESEL ENGINE		Part Number	Qty	Notes	
Estimated Lift 10mm	No Bar	Spring	2605	1	
		Strut - N/Sport	90008	2	4
		Strut - N/Plus	93008		4,10
	Bar Only	Spring	2606	1	
		Strut - N/Sport	90008	2	4
		Strut - N/Plus	93008		4,10
	Bar/ Winch/ Accessories	Spring	3027	1	
		Strut - N/Sport	90008	2	4
		Strut - N/Plus	93008		4,10

Comments

- 1 OMEGS16 is a **mandatory** fitment to prevent springs from inverting.
- 2 OMESB38 is a **mandatory** fitment to OME springs only. Include tray weight in constant load calculation. Springs can **only be** installed with OME bush kit.
- 3 Reverse centre bolt to allow fitment.
- 4 No top mounting bushes supplied use OME3121. OE bushes may be re-used if in good condition.
- 5 OMEU71 is to be used with CS053R and CS054R.
- 6 OMEU76 is to be used with CS022R and CS023R.
- 7 D32XL suitable for CS053R, CS054R and CS022R.
- 8 Strut Top Hat Kit may be required if original equipment is worn.
- 9 Refer to **Leaf Spring Service Parts** section for Centre Bolt selection.
- 10 Does not suit OE Coil.

FRONT SELECTION

V6 PETROL ENGINE		Part Number	Qty	Notes	
Estimated Lift 10mm	No Bar	Spring	2611	1	
		Strut - N/Sport	90008	2	4
		Strut - N/Plus	93008		4,10
	Bar Only	Spring	2605	1	
		Strut - N/Sport	90008	2	4
		Strut - N/Plus	93008		4,10
	Bar/ Winch/ Accessories	Spring	2606	1	
		Strut - N/Sport	90008	2	4
		Strut - N/Plus	93008		4,10

FIT KITS & HARDWARE

Loc	Description	Part Number	Qty	Note
F	UPPER STRUT BUSHES	OME3121	2	4
F	STUT TOP HAT KIT	OMETH001		8

REAR SELECTION

ALL MODELS		Part Number	Qty	Notes	
Estimated Lift 20mm	Medium Load	Leaf Spring	CS053R	2	3
		Shock - N/Sport	60036		
		Shock - N/Plus	63036		
	Constant 300kg	Leaf Spring	CS054R	2	3
		Shock - N/Sport	60036		
		Shock - N/Plus	63036		
	Constant 500kg	Leaf Spring	CS022R	2	3
		Shock - N/Sport	60036		
		Shock - N/Plus	63036		
	Constant 800kg	Leaf Spring	CS023R	2	3
		Strut - N/Sport	60036		
		Strut - N/Plus	63036		
	U BOLTS		OMEU71	4	5
			OMEU76		6
	SPRING BUSH KIT		OMESB38	2	2
GREASABLE SHACKLE KIT		OMEGS16	1	1	
GREASABLE FIXED END PIN KIT		OMEGP12			

FIT KITS & HARDWARE

Loc	Description	Part Number	Qty	Note
R	EXTRA LEAF	D32XL	2	7
R	CENTRE BOLT			9

FRONT SELECTION⁴

PETROL & DIESEL MODELS		Part Number	Qty	Notes
Bar/ Winch/ Accessories	Torsion Bars	303006	1	1
	Shock - N/Sport	60040	2	

REAR SELECTION⁴

ALL MODELS		Part Number	Qty	Notes	
Estimated Lift 40mm	Medium Load	Leaf Spring	CS022R	2	2,3
		Shock - N/Sport	60050		
	Constant 200kg	Leaf Spring	CS023R	2	2,3
		Shock - N/Sport	60050		
	U BOLT		OMEU57	4	
	SPRING BUSH KIT		OMESB38	2	2
	ANTI INVERSION KIT		FK30	1	3
	GREASABLE SHACKLE KIT		OMEGS16		3
	GREASABLE FIXED END PIN KIT		OMEGP12		

Comments

1 Raise or lower front end clearance and trim vehicle by adjusting front torsion bars.

Important: A minimum of 60mm of droop **must** be maintained.

Torsion bar 303006 suits 1993 On Models with 39 splines.

2 OMESB38 is a **mandatory** fitment to OME springs only. Include tray weight in constant load calculation. Springs can be **only** installed with OME Bush Kit.

3 FK30 Anti-Inversion Kit is a **mandatory** fitment, with or without Greasable Shackle Kit.

4 When remaining stock of N18 and N30E is exhausted no further product will be available.

FRONT SELECTION

PETROL & DIESEL MODELS		Part Number	Qty	Notes
Bar/ Winch/ Accessories	Torsion Bars	303006	1	1
	Shock - N/Sport	60051	2	

REAR SELECTION^a

ALL MODELS		Part Number	Qty	Notes	
Est Lift: 40mm	Medium Load	Leaf Spring	CS022R	2	2,3
		Shock - N/Sport	60058		
	Constant 200kg	Leaf Spring	CS023R	2	2,3
		Shock - N/Sport	60058		
	U BOLT		OMEU57	4	
	SPRING BUSH KIT		OMESB38	2	2
	ANTI INVERSION KIT		FK30	1	3
	GREASABLE SHACKLE KIT		OMEGS16		

Comments

1 Raise or lower front end clearance and trim vehicle by adjusting front torsion bars.

Important: A minimum of 60mm of droop **must** be maintained.

Torsion bar 303006 suits 1993 On Models with 39 splines.

2 OMESB38 is a mandatory fitment to OME springs only. Include tray weight in constant load calculation. Springs can be **only** installed with OME Bush Kit.

3 FK30 Anti-Inversion Kit is a **mandatory** fitment, with or without Greasable Shackle Kit.

4 When remaining stock of N30E is exhausted no further product will be available.

FRONT SELECTION

		V8 PETROL ENGINE	Part Number	Qty	Notes
Estimated Lift 20mm	No Bar	Spring	2977	1	
		Strut - N/Sport	90014	2	2
	Bar Only	Spring	2978	1	
		Strut - N/Sport	*90015 / 90014	2	2
	Bar/ Winch/ Accessories	Spring	2979	1	
		Strut - N/Sport	90015	2	2
	BP-51	Coilover LH	BP5190008L	1+1	
		Coilover RH	BP5190008R		
		Fit Kit	VM80010020	1	

Comments

- 1** It is recommended that a 4 wheel alignment is carried out.
- 2** No top mounting bushes supplied, re-use OE bushes.

REAR SELECTION

		DIESEL ENGINE	Part Number	Qty	Note
Estimated Lift 50mm	Medium Load	Spring	2986	1	1
		Shock - N/Sport	60084	2	
	Constant 200kg	Spring	2987	1	1
		Shock - N/Sport	60084	2	
	Constant 400kg	Spring	2988	1	1
		Shock - N/Sport	60084	2	
	BP-51	Shock	BP5160058	2	
		Fit Kit	VM80010021	1	

FRONT SELECTION

4.5 & 4.8 PETROL & 4.2 DIESEL		Part Number	Qty	Notes
Estimated Lift 50mm	Bar Only	Spring	2970	1
		Shock - N/Sport	61012	2
		Shock - N/Plus	63012	
	Bar/ Winch/ Accessories	Spring	2971	1
		Shock - N/Sport	60013	2
		Shock - N/Plus	63013	
	Bar Only 20mm	Spring	2972	1
		Shock - N/Sport	61012	2
		Shock - N/Plus	63012	
	BP-51	Shock	BP5160038	2
		Fit Kit	VM80010022	1

Comments

- 1 Coil trim packers may be required to trim vehicles. Packers must be installed to the bottom of front coils. Not suitable for rear coils.
- 2 OMECA77B Caster Kit will increase caster angle by 2 degrees. Check manufacturer's specifications to determine if OMECA77B Caster Kit is required.
- 3 FK18: Rear Sway Bar Extension Bracket is **mandatory** fitment to prevent damage to sway bar when suspension is at full extension. FK24 suits Models with detachable sway bar.

FRONT SELECTION

2.8 DIESEL & 3.0 TURBO		Part Number	Qty	Note
Estimated Lift 50mm	Bar Only	Spring	2973	1
		Shock - N/Sport	61012	2
		Shock - N/Plus	63012	
	Bar/ Winch/ Accessories	Spring	2970	1
		Shock - N/Sport	60013	2
		Shock - N/Plus	63013	
	Bar Only 20mm	Spring	2974	1
		Shock - N/Sport	61012	2
		Shock - N/Plus	63012	
	BP-51	Shock	BP5160038	2
		Fit Kit	VM80010022	1

4 **Special Note:** Due to limited clearance between tailshaft and chassis cross member, OME does not recommend fitment of gear box packers.

5 OMESD11 Steering Damper fits all Models To 1/2000. OMESD01 fits 2/2000 Models On. To verify correct fitment for individual vehicles compare OE mounts with Steering Stabilisers Specifications section.

6 It is highly recommended to reinforce coil towers if fitting heavy rear springs.

7 Fitment to vehicle with original exhaust, if larger exhaust fitted some modifications to exhaust may be required.

FIT KITS & HARDWARE

Loc	Description	Part Number	Qty	Note
F	CASTER KIT	OMECA77B	1	2
F	STEERING DAMPER	OMESD11	Ea	5
		OMESD01		
F	TRIM PACKER	OMEGQPF05	1	1
		OMEGQPF10		

8 United Arab Emirates ONLY use BP-51 Fit Kit VM80010032.

REAR SELECTION

ALL MODELS		Part Number	Qty	Notes	
Estimated Lift 50mm	Medium Load	Spring	2980	1	4
		Shock - N/Sport	61014	2	
		Shock - N/Plus	63014		
	Constant 200kg	Spring	2981	1	4
		Shock - N/Sport	60015	2	
		Shock - N/Plus	63015		
	Constant 400kg	Spring	2985	1	6
		Shock - N/Sport	60015	2	
		Shock - N/Plus	63015		
	Medium Load 30mm	Spring	2982	1	4
		Shock - N/Sport	61014	2	
		Shock - N/Plus	63014		
	BP-51	Shock	BP5160039	2	7
		Fit Kit	VM80010041	1	

FIT KITS & HARDWARE

Loc	Description	Part Number	Qty	Notes
R	SWAY BAR EXTENSION KIT	FK18	1	3
		FK24		

FRONT SELECTION

ALL LWB MODELS		Part Number	Qty	Notes
Bar Only	Spring - 75mm	2412	1	
	Spring - 100mm	2413		
	Spring - 125mm	2414		
Bar/ Winch/ Accessories	Spring - 75mm	3033	1	
	Spring - 100mm	3036		
Shock 100mm	Nitrocharger Sport	60013L	2	1
	Nitrocharger Plus	63013L		
BP-51 100mm	Shock	BP5160040	2	1
	Fit Kit	VM80010022	1	8
		VM80010032		

Lift increase is approximate and will depend on vehicle weights.

Modifications for off road use only.

The products listed in this selection chart are deemed by Old Man Emu to be suitable for off road use and their legality for public road use should be certified by the relevant Registration Authority. An Off Road Use Only Disclaimer must be signed by the customer.

Modifications and replacement of other associated components will be required.

FIT KITS & HARDWARE

Loc	Description	Part Number	Qty	Note
F	STEERING DAMPER	OMESD34	1	2
		OMESD36		
		OMESD11		
		OMESD01		
F	ADJ PANHARD ROD	PANR004	1	3
F	ADJ PANHARD ROD W/SPHERICAL	PANR028X		
F	PANHARD SPHERICAL BEARING	OME3098		
F	TRIM PACKER	OMEGQPF05	EA	5
		OMEGQPF10		
F	GEARBOX PACKER KIT	GQGK01	1	4

Warranty will be void if the shocks have been used in a racing application.

Comments

- 1 Shocks are designed around a 100mm coil - compatibility for 75mm & 125mm need to be determined by the installer with open and closed lengths checked as well as bump stop contact measurements.
- 2 OMESD34 Suits GQ Pre 8/1989 Models
OMESD36 Suits GQ 8/1989 On Models
OMESD11 Suits GU Pre 01/2000 Models
OMESD01 Suits GU 01/2000 On Models
- 3 PANR004 Suits Pre 01/00 wagon CC Models RHD Only.
PANR028X Suits 01/2000 On models not CC, RHD Only.
PANR005 Suits Pre 01/00 wagon CC Models RHD & LHD, does not suit H260 Differential.
PANR029X Suits 01/2000 On models not CC, RHD & LHD, does not suit H260 Differential.
OME3098 Suits OE & Adjustable 01/00 On
- 4 GQGK01 Suits GQ Models Only
- 5 Coil trim packers may be required to trim vehicles. Packers must be installed to the bottom of front coils only.
- 6 Coil Tower reinforcement is highly recommended
- 7 LTA3044 - Standard Length Arms
UTAA106 - 50mm on car adjustable
- 8 Suits United Arab Emirates only

REAR SELECTION

ALL LWB MODELS		Part Number	Qty	Notes
Medium Load	Spring - 75mm	2415	1	
	Spring - 100mm	2416		
	Spring - 125mm	2417		
Constant 200kg	Spring - 75mm	3034	1	
	Spring - 100mm	3037		
Constant 400kg	Spring - 75mm	3035	1	6
	Spring - 100mm	3038		
Shock 100mm	Nitrocharger Sport	60015L	2	1
	Nitrocharger +	63015L		
BP-51 100mm	Shock	BP5160041	2	1
	Fit Kit	VM80010041	1	

FIT KITS & HARDWARE

Loc	Description	Part Number	Qty	Note
R	ADJ PANHARD ROD	PANR005	1	3
R	ADJ PANHARD ROD W/SPHERICAL	PANR029X		
R	PANHARD SPHERICAL BEARING	OME3098		
R	H/DUTY LOWER TRAILING ARMS	LTA3044		
R	ADJ UPPER TRAILING ARMS	UTAA106		
R	TRIM PACKER	OMEGQPR05	EA	5
		OMEGQPR10		

FRONT SELECTION

2.8 & 3.0 TURBO DIESEL		Part Number	Qty	Notes
Estimated Lift 40mm	Bar Only	Spring	2974E	1
		Shock - N/Sport	61012	2
		Shock - N/Plus	63012	
	Bar/ Winch/ Accessories	Spring	2972E	1
		Shock - N/Sport	60013	2
		Shock - N/Plus	63013	
	BP-51	Shock	BP5160038	2
		Fit Kit	VM80010022	1

Comments

- OMESD01 fits 2/2000 On Models.
OMESD11 fits all Models To 1/2000.
- OMECA77B Caster Kit will increase caster angle by 2 degrees. Check manufacturer's specifications to determine if OMECA77B Caster Kit is required.
- FK25 x 2 Oil Pan Kits **must** be installed when OMECA77B Caster Kit or GQGK02 Gear Box Packer Kit are fitted.
- FK18: Rear Sway Bar Extension Bracket is **mandatory** fitment to Models with fixed sway bar to prevent damage to sway bar when suspension is at full extension. FK24 suits Models with detachable sway bar.
- GQGK02 Gear Box Packer Kit is designed to space down the gear box cross member from the chassis to reduce tail shaft flange angle thereby reducing driveline vibration. In some cases two (2) kits may be required.

FIT KITS & HARDWARE

Loc	Description	Part Number	Qty	Note
F	TRIM PACKER	OMEGQPF05 OMEGQPF10	EA	
F	STEERING DAMPER	OMESD01 OMESD11	1	1
F	CASTER KIT	OMECA77B		2,3
F	OIL PAN PACKER KIT	FK25		3

REAR SELECTION

ALL MODELS		Part Number	Qty	Note	
Estimated Lift 40mm	Light Load	Spring	2GQ02A	1	
		Shock - N/Sport	61014	2	
		Shock - N/Plus	63014		
	Medium Load	Spring	2GQ02B	1	
		Shock - N/Sport	61014	2	
		Shock - N/Plus	63014		
	Constant 200kg	Spring	2GQ02D	1	
		Shock - N/Sport	60015	2	
		Shock - N/Plus	63015		
	BP-51	Shock	BP5160039	2	6
		Fit Kit	VM80010041	1	

- Fitment to vehicle with original exhaust, if larger exhaust fitted some modifications to exhaust may be required.
- United Arab Emirates ONLY use BP-51 Fit Kit VM80010032.

FIT KITS & HARDWARE

Loc	Description	Part Number	Qty	Note
R	SWAY BAR EXTENSION KIT	FK18 FK24	1	4
R	GEAR BOX PACKER KIT	GQGK02		3,5
R	TRIM PACKER	OMEGQPR05 OMEGQPR10	EA	

FRONT SELECTION

4.2 DIESEL ENGINE		Part Number	Qty	Notes	
Estimated Lift 50mm	Bar Only	Spring	2970	1	
		Shock - N/Sport	61012	2	2
		Strut - N/Plus	63012		
	Bar/ Winch/ Accessories	Spring	2971	1	
		Shock - N/Sport	60013	2	2
		Strut - N/Plus	63013		
	BP-51	Shock	BP5160038	2	
		Fit Kit	VM80010022	1	5

Comments

- 1 OMECA77B Caster Kit will increase caster angle by 2 degrees. Check manufacturer's specifications to determine if OMECA77B Caster Kit is required.
- 2 Coil trim packers may be required to trim vehicle to a maximum of 15mm. Packers must be installed to the bottom on front coil.
- 3 FK18 Rear Sway Bar Extension Bracket is **mandatory** fitment to prevent damage to sway bar when suspension is at full
- 4 Fitment to vehicle with original exhaust, if larger exhaust fitted some modifications to exhaust may be required.
- 5 United Arab Emirates ONLY use BP-51 Fit Kit VM80010032.

FRONT SELECTION

3.0 DIESEL ENGINE		Part Number	Qty	Note	
Estimated Lift 50mm	Bar Only	Spring	2973	1	
		Shock - N/Sport	61012	2	2
		Shock - N/Plus	63012		
	Bar/ Winch/ Accessories	Spring	2970	1	
		Shock - N/Sport	60013	2	2
		Shock - N/Plus	63013		
	BP-51	Shock	BP5160038	2	
		Fit Kit	VM80010022	1	5

FIT KITS & HARDWARE

Loc	Description	Part Number	Qty	Note
F	TRIM PACKER	OMEGQPF05	EA	2
		OMEGQPF10		
F	STEERING DAMPER	OMESD11	1	1
F	CASTER KIT	OMECA77B		

REAR SELECTION

ALL MODELS		Part Number	Qty	Notes	
Estimated Lift 50mm	Medium Load	Spring	2983	1	
		Shock - N/Sport	61014	2	
		Shock - N/Plus	63014		
	Constant 300kg	Spring	2984	1	
		Shock - N/Sport	60015	2	
		Shock - N/Plus	63015		
	Constant 600kg	Spring	2985	1	
		Shock - N/Sport	60015	2	
		Shock - N/Plus	63015		
	BP-51	Shock	BP5160039	2	4
		Fit Kit	VM80010041	1	

FIT KITS & HARDWARE

Loc	Description	Part Number	Qty	Note
R	SWAY BAR EXTENSION KIT	FK18	1	3

Note: Do not use trim packers on rear coils

FRONT SELECTION

4.2 DIESEL ENGINE			Part Number	Qty	Notes
Estimated Lift 50mm	Bar Only	Spring	2970	1	
		Shock - N/Sport	60055	2	
		Shock - N/Plus	63055		
	Bar/ Winch/ Accessories	Spring	2971	1	
		Shock - N/Sport	60055	2	
		Shock - N/Plus	63055		

Comments

1 Coil trim packers may be required to trim vehicle to a maximum of 15mm per coil. Packers must be installed to the bottom on front coils.

2 OMECA77B Caster Kit will increase caster angle by 2 degrees. Check manufacturer's specifications to determine if OMECA77B Caster Kit is required.

3 FK08 Anti Inversion Kit is **mandatory** fitment if greasable shackles are not fitted. Refer OME Technical & Fitting Manual.

4 For improved ride quality on vehicles carrying medium loads remove the 3rd leaf. Include tray weight in constant load calculation.

5 Refer to **Leaf Spring Service Parts** section for Centre Bolt selection.

FRONT SELECTION

3.0 DIESEL ENGINE			Part Number	Qty	Note
Estimated Lift 50mm	Bar Only	Spring	2973	1	
		Shock - N/Sport	60055	2	
		Shock - N/Plus	63055		
	Bar/ Winch/ Accessories	Spring	2970	1	
		Shock - N/Sport	60055	2	
		Shock - N/Plus	63055		

FIT KITS & HARDWARE

Loc	Description	Part Number	Qty	Note
F	TRIM PACKER	OMEGQPF05	EA	1
		OMEGQPF10		
F	STEERING DAMPER	OMESD11	1	
F	CASTER KIT	OMECA77B		2

REAR SELECTION

ALL MODELS			Part Number	Qty	Notes
Estimated Lift 50mm	Medium Load	Leaf Spring	CS016RA/B	1+1	3,4
		Shock - N/Sport	60054	2	
		Shock - N/Plus	63054		
	Constant 400kg	Leaf Spring	CS016RA/B	1+1	3,4
		Shock - N/Sport	60054	2	
		Shock - N/Plus	63054		
	SPRING BUSH KIT		OMESB64	2	
	GREASABLE SHACKLE KIT		OMEGS1	1	
	GREASABLE SHACKLE END PIN KIT		OMEGP2		
	U BOLT		OMEU64	4	
BRAKE PROPORTIONING BRACKET		FK78	1		

FIT KITS & HARDWARE

Loc	Description	Part Number	Qty	Note
R	ANTI INVERSION KIT	FK08	1	3
R	EXTRA LEAF	D15XL	2	
R	CENTRE BOLT			5

FRONT SELECTION

4.2 DIESEL ENGINE		Part Number	Qty	Notes
Estimated Lift 40-50mm	Bar Only	Spring	2975	1
		Shock - N/Sport	61012	2
		Shock - N/Plus	63012	
	Bar/ Winch/ Accessories	Spring	2976	1
		Shock - N/Sport	60013	2
		Shock - N/Plus	63013	
	Bar Only 30mm	Spring	2974	1
		Shock - N/Sport	61012	2
		Shock - N/Plus	63012	
	BP-51	Shock	BP5160038	2
		Fit Kit	VM80010022	1

Comments

- 1 Coil trim packers may be required to trim vehicle to a maximum of 15mm per coil. Packers must be installed to the top on rear coils and to the bottom on front coils.
- 2 OMECA77B Caster Kit will increase caster angle by 2 degrees. Check manufacturer's specifications to determine if OMECA77B Caster Kit is required.
- 3 Gearbox Packer Kit is designed to space down the gearbox cross member from the chassis to reduce tail shaft flange angle thereby reducing driveline vibration.
- 4 LPG conversion equated to 100-125 litre rear mounted gas tank and a 70-75 litre mid mounted auxiliary petrol tank.
- 5 OMESD36 fits 8/89 Models On. OMESD34 fits pre 8/89 Models.
- 6 Fitment to vehicle with original exhaust, if larger exhaust fitted some modifications to exhaust may be required.
- 8 Note: **Do not** use trim packers on rear coils.

FRONT SELECTION

2.8 & 3.0 DIESEL ENGINE		Part Number	Qty	Note
Estimated Lift 50mm	Bar Only	Spring	2974	1
		Shock - N/Sport	61012	2
		Shock - N/Plus	63012	
	Bar/ Winch/ Accessories	Spring	2972	1
		Shock - N/Sport	60013	2
		Shock - N/Plus	63013	
	BP-51	Shock	BP5160038	2
		Fit Kit	VM80010022	1

FIT KITS & HARDWARE

Loc	Description	Part Number	Qty	Note
F	TRIM PACKER	OMEGQPF05	EA	1
		OMEGQPF10		
F	STEERING DAMPER	OMESD36	1	5
		OMESD34		
F	CASTER KIT	OMECA77B		2

REAR SELECTION

LWB MODELS		Part Number	Qty	Notes	
Estimated Lift 40-50mm	Light Load	Spring	2GQ02C	1	
		Shock - N/Sport	61014	2	
		Shock - N/Plus	63014		
	Medium Load	Spring	2GQ02AM	1	
		Shock - N/Sport	61014	2	
		Shock - N/Plus	63014		
	Constant 200kg	Spring	2GQ02J	1	
		Shock - N/Sport	60015	2	
		Shock - N/Plus	63015		
	BP-51	Shock	BP5160039	2	6
		Fit Kit	VM80010041	1	

Comments

1 Coil trim packers may be required to trim vehicle to a maximum of 15mm per coil. Packers must be installed to the top on rear coils and to the bottom on front coils.

2 OMECA77B Caster Kit will increase caster angle by 2 degrees. Check manufacturer's specifications to determine if OMECA77B Caster Kit is required.

3 Gearbox Packer Kit is designed to space down the gearbox cross member from the chassis to reduce tail shaft flange angle thereby reducing driveline vibration.

4 LPG conversion equated to 100-125 litre rear mounted gas tank and a 70-75 litre mid mounted auxiliary petrol tank.

5 OMESD36 fits 8/89 Models On. OMESD34 fits pre 8/89 Models.

6 Fitment to vehicle with original exhaust, if larger exhaust fitted some modifications to exhaust may be required.

8 Note: **Do not** use trim packers on rear coils.

REAR SELECTION

SWB MODELS		Part Number	Qty	Notes	
Estimated Lift 40-50mm	Light Load	Spring	2GQ02CM	1	
		Shock - N/Sport	61014	2	
		Shock - N/Plus	63014		
	Medium Load	Spring	2GQ02C	1	
		Shock - N/Sport	61014	2	
		Shock - N/Plus	63014		
	Constant 200kg	Spring	2GQ02G	1	
		Shock - N/Sport	60015	2	
		Shock - N/Plus	63015		
	BP-51	Shock	BP5160039	2	6
		Fit Kit	VM80010041	1	

REAR SELECTION - Estimated Lift 40-50mm

LPG CONVERSIONS		Part Number	Qty	Notes
Medium Load	Spring	2GQ02LP	1	4
	Shock - N/Sport	61014	2	
	Shock - N/Plus	63014		
BP-51	Shock	BP5160039	2	6
	Fit Kit	VM80010041	1	

FIT KITS & HARDWARE

Loc	Description	Part Number	Qty	Note
R	GEAR BOX PACKER KIT	GQGK01	1	3,8

FRONT SELECTION

4.2 DIESEL ENGINE			Part Number	Qty	Notes
Estimated Lift 50mm	Bar Only	Spring	2975	1	
		Shock - N/Sport	61012	2	
		Shock - N/Plus	63012		
	Bar/ Winch/ Accessories	Spring	2976	1	
		Shock - N/Sport	60013	2	
		Shock - N/Plus	63013		
	BP-51	Shock	BP5160038	2	
		Fit Kit	VM80010022	1	

Comments

1 Coil trim packers may be required to trim vehicle to a maximum of 15mm per coil. Packers **must** be installed to the top on rear coils and to the bottom on front coils.

2 OMECA77B Caster Kit will increase caster angle by 2 degrees. Check manufacturer's specifications to determine if OMECA77B Caster Kit is required.

3 Include tray weight in constant load calculation.

4 Gearbox Packer Kit is designed to space down the gearbox cross member from the chassis to reduce tail shaft flange angle thereby reducing driveline vibration.

5 Fitment to vehicle with original exhaust, if larger exhaust fitted some modifications to exhaust may be required.

FIT KITS & HARDWARE

Loc	Description	Part Number	Qty	Note
F/R	TRIM PACKER	OMEGQPF05	EA	1
		OMEGQPF10		
F	STEERING DAMPER	OMESD36	1	
F	CASTER KIT	OMECA77B		2

REAR SELECTION

ALL MODELS			Part Number	Qty	Note
Est Lift 50mm	Medium Load	Spring	2GQ02C	1	3
		Shock - N/Sport	61014	2	
		Shock - N/Plus	63014		
	Constant 200kg	Spring	2GQ02J	1	3
		Shock - N/Sport	60015	2	
		Shock - N/Plus	63015		
	BP-51	Shock	BP5160039	2	5
		Fit Kit	VM80010041	1	

FIT KITS & HARDWARE

Loc	Description	Part Number	Qty	Note
F/R	TRIM PACKER	OMEGQPR05	EA	1
		OMEGQPR10		
R	GEAR BOX PACKER KIT	GQGK01	1	4

FRONT SELECTION

4.2 DIESEL ENGINE		Part Number	Qty	Notes	
Estimated Lift 30mm	Bar Only	Leaf Spring	CS003F	2	1
		Shock - N/Sport	60068		
	Bar/ Winch/ Accessories	Leaf Spring	CS004F	2	1
		Shock - N/Sport	60068		
	SPRING BUSH KIT		OMESB1	2	
	GREASABLE SHACKLE KIT		OMEGS2		
GREASABLE SHACKLE END PIN KIT		OMEGP2	1		
STEERING DAMPER		OMESD22			

Comments

1 CBS02 x 2 Centre Bolt Spacers required for front spring fitment.

2 FK08 Anti Inversion Kit is **mandatory** fitment if greasable shackles are not fitted. Refer OME Technical & Fitting Manual.

3 Include tray weight in constant load calculation.

4 Remove 3rd leaf for vehicles requiring 400kg constant load springs.

5 Refer to **Leaf Spring Service Parts** section for Centre Bolt selection.

6 When remaining stock of N25 is exhausted no further product will be available.

FIT KITS & HARDWARE

Loc	Description	Part Number	Qty	Note
F	CENTRE BOLT SPACER KIT	CBS02	2	1
F	EXTRA LEAF	D1XL		
F	CENTRE BOLT	UCB3		5

REAR SELECTION⁶

ALL MODELS		Part Number	Qty	Note	
Estimated Lift 45mm	Constant 400kg	Leaf Spring	CS016RA/B	1+1	2,3,4
		Shock - N/Sport	60054	2	
	Constant 600kg	Leaf Spring	CS016RA/B	1+1	2,3
		Shock - N/Sport	60054	2	
	SPRING BUSH KIT		OMESB64	2	
	GREASABLE SHACKLE KIT		OMEGS1	1	
GREASABLE FIXED END PIN KIT		OMEGP2			
U BOLT		OMEU58B	4		

FIT KITS & HARDWARE

Loc	Description	Part Number	Qty	Note
R	ANTI INVERSION KIT	FK08	1	2
R	EXTRA LEAF	D15XL	2	
R	CENTRE BOLT			5

FRONT SELECTION

DIESEL ENGINE			Part Number	Qty	Notes	
Estimated Lift 30-40mm	Bar Only	Leaf Spring	CS016F	2	1	
		N/Charger - Early	N19		3	
	Bar/ Winch/ Accessories	Leaf Spring	CS016F	2		
		N/Charger - Early	N19		3	
	SPRING BUSH KIT			OMESB3	2	
				OMESB29		
U BOLT			OMEU56	2+2	2	
			OMEU57			

Comments

- 1** To improve ride quality remove 3rd leaf from top of spring.
- 2** Front U Bolt:
OMEU56 fits to right hand side.
OMEU57 fits to left hand side.
- 3** When remaining stock of N19 and N89 is exhausted no further product will be available.
- 4** Refer to **Leaf Spring Service Parts** section for Centre Bolt selection.

FIT KITS & HARDWARE

Loc	Description	Part Number	Qty	Note
F	EXTRA LEAF	D30XL	2	
F	CENTRE BOLT			4

REAR SELECTION

ALL MODELS			Part Number	Qty	Note	
Estimated Lift 50mm	Medium Load	Leaf Spring	CS011R	2		
		Shock - N/Charger	N89		3	
	Constant 200kg	Leaf Spring	CS012R	2		
		Shock - N/Charger	N89		3	
	SPRING BUSH KIT			OMESB2	2	
				OMESB29		
U BOLT			OMEU58	4		

FIT KITS & HARDWARE

Loc	Description	Part Number	Qty	Note
R	EXTRA LEAF	D12XL	2	
R	CENTRE BOLT			4

FRONT SELECTION

PETROL & DIESEL ENGINE		Part Number	Qty	Notes	
Estimated Lift 30-40mm	Bar Only	Leaf Spring	CS010FA/B	1+1	1
		N/Charger - Early	*N47 / N96	2	6
		N/Charger - Late	N49		
	Bar/ Winch/ Accessories	Leaf Spring	CS011FA/B	1+1	1
		N/Charger - Early	*N47 / N96	2	6
		N/Charger - Late	N49		
	SPRING BUSH KIT		OMESB28	2	2
			OMESB29		
			OMESB31		
			OMESB29		
U BOLT		OMEU56	4	4	
		OMEU57			
STEERING DAMPER		OMESD22	1		

Comments

1 Models with P40 4 litre engine require CS011FA / B springs. Individual vehicles fitted with A / B fitment may experience a pronounced trimming problem to right hand side. In these cases fitment of an XL leaf to the right hand side will correct problem.

2 Front Spring Buses:
Early Model (round headlight) require OMESB28 and OMESB29.
Late Model (square headlight) require OMESB31 and OMESB29.

3 OME Bush Kits **must** be used to enable springs to be fitted.

4 Front U Bolt:
OMEU56 fits to right hand side
OMEU57 fits to left hand side

5 D11XL suitable for CS010FA / B.

6 Early Model: Round Headlight
Late Model: Square Headlight

7 Refer to **Leaf Spring Service Parts** section for Centre Bolt selection.

FIT KITS & HARDWARE

Loc	Description	Part Number	Qty	Note
F	EXTRA LEAF	D11XL	2	5
F	CENTRE BOLT			7

REAR SELECTION

ALL MODELS		Part Number	Qty	Note	
Estimated Lift 50mm	Medium Load	Leaf Spring	CS011R	2	
		Shock - N/Charger	N97		
	Constant 200kg	Leaf Spring	CS012R	2	
		Shock - N/Charger	N48		
	SPRING BUSH KIT		OMESB2	2	3
			OMESB29		
U BOLT		OMEU58	4		

FIT KITS & HARDWARE

Loc	Description	Part Number	Qty	Note
R	EXTRA LEAF	D12XL	2	
R	CENTRE BOLT			7

FRONT SELECTION

TWIN TURBO DIESEL		Part Number	Qty	Notes
Estimated Lift 20mm	No Bar	Spring	3099	1
		Strut - N/Sport	90032	2 1
	Bar Only	Spring	3100	1
		Strut - N/Sport	90032	2 1
	Bar/ Winch/ Accessories	Spring	3101	1
		Strut - N/Sport	90032	2 1
	Nitro +	Spring	4016	1
		Strut	93032	2 1,9
	BP-51	Strut - LH	BP5190016L	1+1
		Strut - RH	BP5190016R	
Fit Kit		VM80010047	1	

FIT KITS & HARDWARE

Loc	Description	Part Number	Qty	Note
F	UPPER STRUT BUSHES	OME3139	2	1
F	STRUT TOP HAT KIT	OMETH005		3
F	TRIM PACKER	FK84	EA	2

Comments

- 1** No top mounting bushes supplied use OME3139. OE bushes may be re-used if in good condition.
- 2** Trim packer FK84 provides approximately 10mm lift at the wheel.
- 3** Strut Top Hat Kit may be required if original equipment is worn.
- 4** Sway Bar/ Brake Fitting Kit FK85 is **required** when fitting all OME rear coil springs.
- 5** OMESB114 suits OE Shackle.
OMESB115 Bush Kits suits OME Greasable Shackle, OMEGS24.
- 6** Use OMEU59A when fitting EL092R.
Use OMEU59B when fitting EL093R and EL094R.
- 7** Fitment of Bump Spacer Kit FK83 is **required** when fitting all OME rear leaf springs.
- 8** EL43XL will give approximately 15mm extra lift or increase loading capacity at design height by approximately 300kgs.
- 9** Does not suit OE coil.

REAR SELECTION

COIL SPRING REAR		Part Number	Qty	Note	
Estimated Lift 50mm	Medium Load	Spring	3191	1	4
		Shock - N/Sport	60136	2	
		Shock - N/Plus	63136		
	Constant 200kg	Spring	3192	1	4
		Shock - N/Sport	*60137 / 60136	2	
		Shock - N/Plus	*63137 / 63136		
	Constant 400kg	Spring	3193	1	4
		Shock - N/Sport	60137	2	
		Shock - N/Plus	63137		
	Constant 600kg	Spring	3194	1	4
		Shock - N/Sport	60137	2	
		Shock - N/Plus	63137		
	BP-51	Shock	BP5160056	2	
		Fit Kit - Series 4	VM80010048	1	
		Fit Kit - Series 5	VM80010049	1	
	FIT KIT - SWAY BAR / BRAKE		FK85	1	4

Comments

- 1 No top mounting bushes supplied use OME3139. OE bushes may be re-used if in good condition.
- 2 Trim packer FK84 provides approximately 10mm lift at the wheel.
- 3 Strut Top Hat Kit may be required if original equipment is worn.
- 4 Sway Bar/ Brake Fitting Kit FK85 is **required** when fitting all OME rear coil springs.
- 5 OMESB114 suits OE Shackle.
OMESB115 Bush Kits suits OME Greasable Shackle, OMEGS24.
- 6 Use OMEU59A when fitting EL092R.
Use OMEU59B when fitting EL093R and EL094R.
- 7 Fitment of Bump Spacer Kit FK83 is **required** when fitting all OME rear leaf springs.

REAR SELECTION

LEAF SPRING REAR		Part Number	Qty	Note	
Estimated Lift 50mm	Medium Load	Leaf Spring	EL092R		
		Shock - N/Sport	60134	2	
		Shock - N/Plus	63134		4
	Constant 300kg	Leaf Spring	EL093R		
		Shock - N/Sport	*60135 / 60134	2	
		Shock - N/Plus	*63135 / 63134		4
	Constant 600kg	Leaf Spring	EL094R		
		Shock - N/Sport	60135	2	
		Shock - N/Plus	63135		4
	GREASABLE SHACKLE KIT		OMEGS24	1	
	SPRING BUSH KIT		OMESB114	2	5
			OMESB115		
	U BOLT		OMEU59A	4	6
			OMEU59B		
	FIT KIT - BUMP SPACER		FK83	1	7

- 8 EL43XL will give approximately 15mm extra lift or increase loading capacity at design height by approximately 300kgs.

FIT KITS & HARDWARE

Loc	Description	Part Number	Qty	Note
R	EXTRA LEAF	EL43XL	2	8

FRONT SELECTION

TWIN TURBO DIESEL		Part Number	Qty	Notes
Estimated Lift 20-30mm	No Bar	Spring	3099	1
		Strut - N/Sport	90032	2 1
	Bar Only	Spring	3100	1
		Strut - N/Sport	90032	2 1
	Bar/ Winch/ Accessories	Spring	3101	1
		Strut - N/Sport	90032	2 1
	Nitro +	Spring	4016	1
		Strut - N/Plus	93032	2 1,9
	BP-51	Strut - LH	BP5190016L	1+1
		Strut - RH	BP5190016R	
Fit Kit		VM80010047	1	

Comments

- 1 No top mounting bushes supplied use OME3139. OE bushes may be re-used if in good condition.
- 2 Trim packer FK84 provides approximately 10mm lift at the wheel.
- 3 Strut Top Hat Kit may be required if original equipment is worn.
- 4 Sway Bar/Brake Fitting Kit FK85 is **required** when fitting all OME rear coil springs.
- 5 OMESB114 suits OE Shackle.
OMESB115 Bush Kits suits OME Greasable Shackle, OMEGS24.
- 6 Use OMEU59A when fitting EL092R.
Use OMEU59B when fitting EL093R and EL094R.
- 7 Fitment of Bump Spacer Kit FK83 is **required** when fitting all OME rear leaf springs.
- 8 EL43XL will give approximately 15mm extra lift or increase loading capacity at design height by approximately 300kgs.
- 9 Does not suit OE coil.

FRONT SELECTION

SINGLE TURBO DIESEL		Part Number	Qty	Notes
Estimated Lift 20-30mm	No Bar	Spring	2608	1
		Strut - N/Sport	90032	2 1
	Bar Only	Spring	3099	1
		Strut - N/Sport	90032	2 1
	Bar/ Winch/ Accessories	Spring	3100	1
		Strut - N/Sport	90032	2 1
	Nitro +	Spring	4011	1
		Strut - N/Plus	93032	2 1,9

FIT KITS & HARDWARE

Loc	Description	Part Number	Qty	Note
F	UPPER STRUT BUSHES	OME3139	2	1
F	STRUT TOP HAT KIT	OMETH005		3
F	TRIM PACKER	FK84	EA	2

REAR SELECTION

COIL SPRING REAR		Part Number	Qty	Notes	
Estimated Lift 30mm	Medium Load	Spring	3095	1	4
		Shock - N/Sport	60136	2	
		Shock - N/Plus	63136		
	Constant 200kg	Spring	3096	1	4
		Shock - N/Sport	*60137 / 60136	2	
		Shock - N/Plus	*63137 / 63136		
	Constant 400kg	Spring	3097	1	4
		Shock - N/Sport	60137	2	
		Shock - N/Plus	63137		
	Constant 600kg	Spring	3098	1	4
		Shock - N/Sport	60137	2	
		Shock - N/Plus	63137		
	BP-51	Shock	BP5160056	2	
		Fit Kit	VM80010048	1	
FIT KIT - SWAY BAR / BRAKE		FK85	1	4	

Comments

- 1** No top mounting bushes supplied use OME3139. OE bushes may be re-used if in good condition.
- 2** Trim packer FK84 provides approximately 10mm lift at the wheel.
- 3** Strut Top Hat Kit may be required if original equipment is worn.
- 4** Sway Bar/Brake Fitting Kit FK85 is **required** when fitting all OME rear coil springs.
- 5** OMESB114 suits OE Shackle.
OMESB115 Bush Kits suits OME Greasable Shackle, OMEGS24.

REAR SELECTION

LEAF SPRING REAR		Part Number	Qty	Notes	
Estimated Lift 40mm	Medium Load	Leaf Spring	EL092R	2	
		Shock - N/Sport	60134		
		Shock - N/Plus	63134		
	Constant 300kg	Leaf Spring	EL093R	2	
		Shock - N/Sport	*60135 / 60134		
		Shock - N/Plus	*63135 / 63134		
	Constant 600kg	Leaf Spring	EL094R	2	
		Shock - N/Sport	60135		
		Shock - N/Plus	63135		
	GREASABLE SHACKLE KIT		OMEGS24	1	
	SPRING BUSH KIT		OMESB114	2	5
			OMESB115		
	U BOLT		OMEU59A	4	6
			OMEU59B		
FIT KIT - BUMP SPACER		FK83	1	7	

- 6** Use OMEU59A when fitting EL092R.
Use OMEU59B when fitting EL093R and EL094R.
- 7** Fitment of Bump Spacer Kit FK83 is **required** when fitting all OME rear leaf springs.
- 8** EL43XL will give approximately 15mm extra lift or increase loading capacity at design height by approximately 300kgs.

FIT KITS & HARDWARE

Loc	Description	Part Number	Qty	Note
R	EXTRA LEAF	EL43XL	2	8

FRONT SELECTION - Estimated Lift 20-30mm

DIESEL & V6 PETROL		Part Number	Qty	Notes
Bar Only	Spring	2607	1	
	Strut - N/Sport	90003	2	1
Bar/ Winch/ Accessories	Spring	2608	1	
	Strut - N/Sport	90003	2	1
Nitro +	Spring	4031	1	
	Strut - N/Plus	93003	2	1,7

FRONT SELECTION - Estimated Lift 20-30mm

V6 TURBO DIESEL		Part Number	Qty	Note
Bar Only	Spring	2608	1	
	Strut - N/Sport	90003	2	1
Bar/ Winch/ Accessories	Spring	2631	1	
	Strut - N/Sport	90003	2	1
Nitro +	Spring	4011	1	
	Strut - N/Plus	93003	2	1,7

FIT KITS & HARDWARE

Loc	Description	Part Number	Qty	Note
F	UPPER STRUT BUSHES	OME3139	2	1
F	STRUT TOP HAT KIT	OMETH005		5

REAR SELECTION

ALL MODELS		Part Number	Qty	Note	
Estimated Lift 40mm	Medium Load	Leaf Spring	CS150R	3	
		Shock - N/Sport	60017	2	
		Shock - N/Plus	63017		
	Constant 400kg	Leaf Spring	CS151R	2	3
		Shock - N/Sport	*60110 / 60017		
		Shock - N/Plus	*63110 / 63017		
	SPRING BUSH KIT		OMESB99	2	2
			OMESB100		
	GREASABLE SHACKLE KIT		OMEGS15	1	
	U BOLT		OMEU53A	4	4

FIT KITS & HARDWARE

Loc	Description	Part Number	Qty	Note
R	EXTRA LEAF	D31XL	2	
R	CENTRE BOLT			6

Comments

- 1 No top mounting bushes supplied use OME3139. OE bushes may be re-used if in good condition.
- 2 Use: OMESB99 with OE Shackles. OMESB100 when installing OMEGS15.
- 3 Include tray weight in constant load calculation.
- 4 OE U bolt plate bolt holes may need to be enlarged when fitting OME U bolts.
- 5 Strut Top Hat Kit may be required if original equipment is worn.
- 6 Refer to **Leaf Spring Service Parts** section for Centre Bolt selection.
- 7 Does not suit OE coil.

FRONT SELECTION

ALL MODELS		Part Number	Qty	Notes
No Bar	Torsion Bars	303007	1	1
	Shock - N/Sport	60034	2	2

REAR SELECTION

ALL MODELS		Part Number	Qty	Note	
Estimated Lift 40mm	Medium Load	Leaf Spring	CS032R	2	4
		Shock - N/Sport	60035		8
	Constant 200kg	Leaf Spring	CS031R	2	4
		Shock - N/Sport	60035		8
	SPRING BUSH KIT		OMESB91	2	6
			OMESB105		
	GREASABLE SHACKLE KIT		OMEGS21	1	
	U BOLT		OMEU63	4	
	U BOLT THREAD SPACER KIT		FK01	1	5

FIT KITS & HARDWARE

Loc	Description	Part Number	Qty	Note
R	EXTRA LEAF	D18XL	2	3
R	CENTRE BOLT			7

Comments

1 Raise or lower front end clearance and trim vehicle by adjusting front torsion bars. **Important:** A minimum of 60mm of droop **must** be maintained.

2 It may be necessary to slightly increase the clearance in the front wishbone to allow shock absorber to fit. Do not modify shock absorber.

3 Include tray weight in constant load calculation. For constant 400kg loads, add D18XL to CS031R.

4 CS032R has a 25mm lower cambered 2nd stage for improved ride quality, however this will cause the ride height under heavy load to be 25mm lower.

5 FK01 U Bolt Thread Spacer Kit required on all cab chassis Models.

6 OMESB91 suits OE Shackle.
OMESB105 suits OME Greasable Shackle OMEGS21.

7 Refer to **Leaf Spring Service Parts** section for Centre Bolt selection.

8 When remaining stock of N59 is exhausted no further product will be available.

FRONT SELECTION

ALL MODELS		Part Number	Qty	Notes
No Bar	Torsion Bars	303007	1	1
		303008		
	Shock - N/Sport	60021	2	2

REAR SELECTION

ALL MODELS		Part Number	Qty	Note	
Est Lift 30mm	Medium Load	Leaf Spring	CS030R	2	
		Shock - N/Sport	60035		5
	Constant 200kg	Leaf Spring	CS031R	2	3
		Shock - N/Sport	60035		5
	SPRING BUSH KIT		OMESB81	2	
	U BOLT		OMEU63	4	

FIT KITS & HARDWARE

Loc	Description	Part Number	Qty	Note
R	EXTRA LEAF	D18XL	2	3
R	CENTRE BOLT			4

Comments

1 Raise or lower front end clearance and trim vehicle by adjusting front torsion bars. **Important:** A minimum of 60mm of droop **must** be maintained. 303007 suits D22 and 303008 suits D21 Models.

2 It may be necessary to slightly increase the clearance in the front wishbone to allow shock absorber to fit. Do not modify shock absorber.

3 For constant 400kg loads, add D18XL to CS031R. Include tray weight in constant load calculation.

4 Refer to **Leaf Spring Service Parts** section for Centre Bolt selection.

5 When remaining stock of N59 is exhausted no further product will be available.

FRONT SELECTION - Estimated Lift 20-30mm

DIESEL & V6 PETROL		Part Number	Qty	Notes
No Bar	Spring	2607	1	
	Strut - N/Sport	90003	2	1
Bar Only	Spring	2608	1	
	Strut - N/Sport	90003	2	1
Nitro +	Spring	4031	1	
	Strut - N/Plus	93003	2	1,3

Comments

1 A 4 wheel alignment must be carried out after fitment of OME suspension. No top mounting bushes supplied use OME3139. OE bushes may be re-used if in good condition.

2 Strut Top Hat Kit may be required if original equipment is worn.

3 Does not suit OE coil.

FRONT SELECTION - Estimated Lift 20-30mm

V6 TURBO DIESEL		Part Number	Qty	Note
No Bar	Spring	2608	1	
	Strut - N/Sport	90003	2	1
Bar Only	Spring	2631	1	
	Strut - N/Sport	90003	2	1
Nitro +	Spring	4011	1	
	Strut - N/Plus	93003	2	1,3

FIT KITS & HARDWARE

Loc	Description	Part Number	Qty	Note
F	UPPER STRUT BUSHES	OME3139	2	1
F	STRUT TOP HAT KIT	OMETH005		2

REAR SELECTION - Estimated Lift 40mm

ALL MODELS		Part Number	Qty	Note
Medium Load	Spring	2609	1	
	Shock - N/Sport	60016	2	
	Shock - N/Plus	63016		
Constant 200kg	Spring	2610	1	
	Shock - N/Sport	60016	2	
	Shock - N/Plus	63016		

FRONT SELECTION - Estimated lift 15mm

V6 MODEL		Part Number	Qty	Notes
No Bar	Spring	2921	1	
Bar Only	Spring	2923		
Bar/ Winch	Spring	2928		

Comments

1 N61: Suits Models To 1/'99. N104: Suits Models from 2/'99 On.

REAR SELECTION - Estimated Lift 20mm

ALL MODELS		Part Number	Qty	Note
Medium Load	Spring	2922	1	
	Shock - N/Charger	N61	2	1
	Shock - N/Charger	N104		1

FRONT SELECTION

V6 MODEL		Part Number	Qty	Notes
No Bar	Torsion Bars	-	1	1
	Shock - N/Sport	60031	2	2,3
	Shock - N/Plus	63031		

REAR SELECTION - Estimated Lift 20mm

ALL MODELS		Part Number	Qty	Note
Medium Load	Spring	2920	1	
	Shock - N/Charger	N89	2	3
	Shock - N/Sport	*60064 / 60032		
	Shock - N/Plus	*63064 / 63032		

Comments

- 1** Raise or lower front end clearance and trim vehicle by adjusting front torsion bars. **Important:** A minimum of 60mm of droop **must** be maintained.

- 2** It may be necessary to slightly increase the clearance in the front wishbone to allow shock absorber to fit. Do not modify shock absorber.

- 3** When remaining stock of N89, 60031, 60032 and 60064 is exhausted no further product will be available.

FRONT SELECTION

PETROL & DIESEL ENGINE		Part Number	Qty	Notes
No Bar	Torsion Bars	-	1	1
	Shock - N/Sport	60031	2	2

REAR SELECTION - Estimated Lift 20mm

ALL MODELS		Part Number	Qty	Note
Medium Load	Spring	2920	1	
	Shock - N/Sport	60058	2	

Comments

1 Raise or lower front end clearance and trim vehicle by adjusting front torsion bars.

2 It may be necessary to slightly increase the clearance in the front wishbone to allow shock absorber to fit. Do not modify shock absorber.

FRONT SELECTION

V6 PETROL ENGINE		Part Number	Qty	Notes
Estimated Lift 30mm	Bar Only	Coil Spring	2607	1
		Strut - N/Sport	90003	2
	Bar/ Winch/ Accessories	Coil Spring	2608	1
		Strut - N/Sport	90003	2
	Nitro +	Coil Spring	4031	1
		Strut - N/Plus	93003	2

Comments

- 1** No top mounting bushes supplied, use OME3139. OE bushes may be re-used if in good condition.
- 2** OMESB99 suits factory shackles. OMESB100 suits OMEGS15 Greasable Shackle Kit.
- 3** FK42 is a **mandatory** fitment to space sway bar link away from shock absorber.
- 4** CS061R with D37XL provides approximately 60mm lift over factory with no additional rear load. CS061R with D37XL provides approximately 30mm lift over factory with constant 200kg additional rear load.
- 5** Strut Top Hat Kit may be required if original equipment is worn.
- 6** Does not suit OE coil.

FIT KITS & HARDWARE

Loc	Description	Part Number	Qty	Note
F	UPPER STRUT BUSH	OME3139	2	1
F	STRUT TOP HAT KIT	OMETH005		5

REAR SELECTION

ALL MODELS		Part Number	Qty	Note	
Estimated Lift 30mm	Medium Load	Leaf Spring	CS061R	4	
		Shock - N/Sport	60017	2	
		Shock - N/Plus	63017	6	
	SPRING BUSH KIT		OMESB99	2	2
			OMESB100	2	2
	GREASABLE SHACKLE KIT		OMEGS15	1	2
	U BOLTS		OMEU72	4	
	FITTING KIT		FK42	1	3

FIT KITS & HARDWARE

Loc	Description	Part Number	Qty	Note
R	EXTRA LEAF	D37XL	2	4

FRONT SELECTION

PETROL & DIESEL ENGINE		Part Number	Qty	Notes
No Bar	Torsion Bars	-		
	Shock - N/Sport	60031	2	

REAR SELECTION - Estimated Lift 40mm

ALL MODELS		Part Number	Qty	Note
Medium Load	Spring	2937	1	
	Shock - N/Charger	N118	2	

FRONT SELECTION - Estimated Lift 20mm

2.7, 3.2 PETROL V6 & 1.9 DIESEL		Part Number	Qty	Notes
No Bar	Spring	2623	1	
	Shock - N/Charger	N217S + N218S	1+1	1

Comments

- 1 N217S Left Hand Side.
N218S Right Hand Side.

FRONT SELECTION - Estimated Lift 20mm

2.0 PETROL 4 CYLINDER ENGINE		Part Number	Qty	Notes
No Bar	Spring	2624	1	
	Shock - N/Charger	N217S + N218S	1+1	1

REAR SELECTION - Estimated Lift 20mm

ALL MODELS		Part Number	Qty	Note
Medium Load	Spring	2625	1	
	Shock - N/Charger	OME036	2	

FRONT SELECTION - Estimated Lift 30mm

PETROL 4 & 6 CYLINDER ENGINES		Part Number	Qty	Notes
No Bar	Spring	2959	1	
	Shock - N/Charger	N103S	2	
Bar Only	Spring	2962	1	
	Shock - N/Charger	N103S	2	

Comments

1 Coil Packer OMESJR10 can be used to increase ride height.

FRONT SELECTION - Estimated Lift 30mm

DIESEL ENGINE		Part Number	Qty	Notes
No Bar	Spring	2962	1	
	Shock - N/Charger	N103S	2	
Bar Only	Spring	2962	1	1
	Shock - N/Charger	N103S	2	

FIT KITS & HARDWARE

Loc	Description	Part Number	Qty	Note
F	COIL PACKER	OMESJR10	EA	1

REAR SELECTION - Estimated Lift 30mm

ALL MODELS		Part Number	Qty	Note
Medium Load	Spring	2961	1	
	Shock - N/Charger	N105	2	

FRONT SELECTION - Estimated Lift 25-30mm

V6 PETROL ENGINE		Part Number	Qty	Notes
No Bar	Spring	2950	1	
	Strut - N/Charger	N103S	2	
Bar Only	Spring	2959	1	
	Strut - N/Charger	N103S	2	

FRONT SELECTION - Estimated Lift 30mm

4 CYLINDER PETROL ENGINE		Part Number	Qty	Notes
No Bar	Spring	2960	1	
	Strut - N/Charger	N103S	2	
Bar Only	Spring	2953	1	
	Strut - N/Charger	N103S	2	

REAR SELECTION - Estimated Lift 30mm

ALL MODELS		Part Number	Qty	Note
Light Load	Spring	2954	1	
	Shock - N/Charger	N105	2	
Medium Load	Spring	2955	1	
	Shock - N/Charger	N105	2	

FRONT SELECTION - Estimated Lift 30mm

4 CYLINDER PETROL ENGINE		Part Number	Qty	Notes
No Bar	Spring	2951	1	
	Strut - N/Charger	N103S	2	1

Comments

1 Front strut has 40mm longer travel than original equipment.

REAR SELECTION - Estimated Lift 30mm

ALL MODELS		Part Number	Qty	Note
Medium Load	Spring	2952	1	
	Shock - N/Charger	N32	2	2

2 Rear shock has 50mm longer travel than original equipment.

FRONT SELECTION

1.5L PETROL ENGINE		Part Number	Qty	Notes
Estimated Lift 40mm	No Bar	Spring	3189	1
		Shock - N/Sport	60154	2
		Shock - N/Plus	63154	
	Bar Only	Spring	3144	1
		Strut - N/Sport	60154	2
		Shock - N/Plus	63154	
	Bar/ Winch	Spring	3145	1
		Strut - N/Sport	60154	2
		Shock - N/Plus	63154	

Comments

- 1 Fit OMECA001 to restore caster wheel alignment. Please refer to PIB No.1625 regarding radius arms inconsistencies.
- 2 Headlight sensor fitting kit FK97 is required when fitting all OME extended travel rear shocks.
- 3 Fit FK96 improve ride quality, not mandatory fitment.
- 4 Due to some variances in vehicle production FK99 is an optional but highly recommended fitment if vehicle displays light rear brake line and/or coil contact to rear shock absorber.

FIT KITS & HARDWARE

Loc	Description	Part Number	Qty	Note
F	TRIM PACKER	OMESJF10	EA	
F	CASTER CORRECTION	OMECA001	1	1

REAR SELECTION - Estimated Lift 40mm

ALL MODELS		Part Number	Qty	Note
Medium Load	Spring	3146	1	
	Shock - N/Sport	60155	2	2
	Shock - N/Plus	63155		

FIT KITS & HARDWARE

Loc	Description	Part Number	Qty	Note
R	TRIM PACKER	OMESJR10	EA	
R	PANHARD ROD EXT BKT KIT	FK96	1	3
R	BRAKE EXT & SHOCK MOUNT KIT	FK99		4
R	HEADLIGHT SENSOR KIT	FK97		

FRONT SELECTION - Estimated Lift 40mm

PETROL ENGINE		Part Number	Qty	Notes
No Bar	Spring	2963	1	
	Shock - N/Charger	OME028	2	
Bar Only	Spring	2965	1	
	Shock - N/Charger	OME028	2	

FRONT SELECTION - Estimated Lift 40mm

DIESEL ENGINE		Part Number	Qty	Notes
No Bar	Spring	2965	1	
	Shock - N/Charger	OME028	2	
Bar Only	Spring	2969	1	
	Shock - N/Charger	OME028	2	

REAR SELECTION - Estimated Lift 40mm

ALL MODELS		Part Number	Qty	Note
Medium Load	Spring	2966	1	
	Shock - N/Charger	OME029	2	

FIT KITS & HARDWARE

Loc	Description	Part Number	Qty	Note
R	TRIM PACKER	OMESJR10	EA	

STD TRACK : 1984 - 1988
 SJ50 - SWB
 SJ51 - LWB

WIDE TRACK : 1988 - 1996
 SJ70 - SWB (also fits MG410)
 SJ71 - LWB (also fits MG410WT)

Note: MG410 & MG10WT are Indian built LWB Models.

FRONT SELECTION - Estimated Lift 40mm

1.0L ENGINE		Part Number	Qty	Notes
No Bar	Leaf Spring	CS012FA/B	1+1	5
	Shock - N/Charger	OME015	2	7
Bar Only	Leaf Spring	CS013FA/B	1+1	5
	Shock - N/Charger	OME025	2	

FRONT SELECTION - Estimated Lift 40mm

1.3L ENGINE		Part Number	Qty	Notes
No Bar	Leaf Spring	CS012F/A	1+1	5
	Shock - N/Charger	OME025	2	
Bar Only	Leaf Spring	CS013FA/B	1+1	5
	Shock - N/Charger	OME025	2	

FIT KITS & HARDWARE

Loc	Description	Part Number	Qty	Note
F	SPRING BUSH	OMESB19	2	1
		OMESB25		1
F	U BOLTS REQ'D	OMEU60	EA	3
		OMEU61		
		OMEU61B		
		OMEU62		
F	FITTING KIT	FK06	1	4
F	TRIM PACKER	TP05	EA	
F	STEERING DAMPER	OMESD30	1	
F	EXTRA LEAF	D20XL	2	6
F	CENTRE BOLT			8

REAR SELECTION - Estimated Lift 40mm

ALL MODELS		Part Number	Qty	Note
Medium Load	Leaf Spring	CS038R	2	
	Shock - N/Charger	N43		2
	Shock - N/Charger	OME013		2
Constant 100kg	Leaf Spring	CS039R	2	
	Shock - N/Charger	N43		2
	Shock - N/Charger	OME013		2

FIT KITS & HARDWARE

Loc	Description	Part Number	Qty	Note
R	SPRING BUSH	OMESB19	2	1
		OMESB25		1
R	U BOLTS REQ'D	OMEU60	EA	3
		OMEU62		
R	TRIM PACKER	TP05	EA	
R	EXTRA LEAF	D21XL	2	
R	CENTRE BOLT			8

Comments

- 1 OMESB19 Bush Kit fits all Models except LJ50. OMESB25 Bush Kit only fits Model LJ50.
- 2 OME013 fits all Models except LJ80 and LJ80 II. N43 fits all LJ80 and LJ80 II Models.
- 3 **'88 To '96 1300cc Wide Track Models:**
Front: D/S OMEU61 x 1 / OMEU61B x 1
Front: P/S OMEU60 x 2
Rear: OMEU60 x 4

'84 To '88 1300cc STD Track Models:
Front: D/S OMEU61 x 1 / OMEU61B x 1
Front: P/S OMEU62 x 2
Rear: OMEU62 x 4

'81 To '87 1000cc Models:
Front: D/S OMEU61 x 1 / OMEU61B x 1
Front: P/S OMEU60 x 2
Rear: OMEU60 x 4
- 4 FK06 Kit required for Model with OE stabiliser bar. Refer OME Technical & Fitting Manual.
- 5 **IMPORTANT:** Sierras used in extreme heavy off road use eg. station mustering, must have CS013FA + B installed.
- 6 D20XL is suitable for CS012FA / B.
- 7 When remaining stock of OME015 is exhausted no further product will be available.
- 8 Refer to **Leaf Spring Service Parts** section for Centre Bolt selection.

FRONT SELECTION

DIESEL & V6 PETROL			Part Number	Qty	Notes
Est Lift 30mm	Bar Only	Spring	2607	1	
		Strut - N/Sport	90003	2	1
	Bar/ Winch/ Accessories	Spring	2608	1	
		Strut - N/Sport	90003	2	1
	Nitro +	Spring	4031	1	
		Shock	93003	2	1,5

FIT KITS & HARDWARE

Loc	Description	Part Number	Qty	Note
F	UPPER STRUT BUSHES	OME3139	2	1
F	STRUT TOP HAT KIT	OMETH005		4

REAR SELECTION - Estimated Lift 40mm

ALL MODELS			Part Number	Qty	Note
Estimated Lift 30mm	Medium Load	Leaf Spring	CS150R	2	2
		Shock - N/Sport	60017		
		Shock - N/Plus	63017		
	Constant 400kg	Spring	CS151R	2	2
		Shock - N/Sport	60017		
		Shock - N/Plus	63017		
	SPRING BUSH KIT		OMESB99	2	2
			OMESB100		
	GREASABLE SHACKLE KIT		OMEGS15	1	
	U BOLTS		OMEU53A	4	3

Comments

- 1 OE plastic stone shield **must** be refitted. No top mounting bushes supplied, use OME3139. OE bushes may be re-used if in good condition.
- 2 Use: OMESB99 with OE Shackles. OMESB100 when installing OMEGS15.
- 3 OE U Bolt plate bolt holes may need to be enlarged when fitting OME U Bolts.
- 4 Strut Top Hat Kit may be required if original equipment is worn.
- 5 Does not suit OE coil.

FRONT SELECTION - Estimated Lift 30-40mm

1.9L ENGINE		Part Number	Qty	Notes
Bar Only	Leaf Spring	CS013FA/B	1+1	2
	Shock - N/Charger	OME034	2	
Bar / Winch/ Accessories	Leaf Spring	CS013FA/B	1+1	2
	XL Leaf	D20XL	2	1
	Shock - N/Charger	OME034		

Comments

1 Fitment of XL Leaf D20XL is recommended for weight in excess of 26kg on diesel Model and 75kg on petrol Model.

2 Front: LHS: OMEU60 x 2, RHS: OMEU61B x 2 required when fitting CS013FA/B
Rear: OMEU60 x 4 required when fitting CS039R

3 OMESD30 can be fitted to Models which have an OE steering damper.

4 Fitment of XL leaf D21XL is recommended for LWB Models with constant 100kg rear weight or OE hard top.

5 Refer to **Leaf Spring Service Parts** section for Centre Bolt selection.

FRONT SELECTION - Estimated Lift 30-40mm

1.3L ENGINE		Part Number	Qty	Notes
Bar Only	Leaf Spring	CS012FA/B	1+1	2
	Shock - N/Charger	OME034	2	
Bar / Winch/ Accessories	Leaf Spring	CS013FA/B	1+1	2
	Extra Leaf	D20XL	2	1
	Shock - N/Charger	OME034		

FIT KITS & HARDWARE

Loc	Description	Part Number	Qty	Note
F	SPRING BUSH	OMESB19	2	
F	U BOLTS	OMEU60 OMEU61B		2
F	CENTRE BOLT			5
F	STEERING DAMPER	OMESD30	1	3
F	TRIM PACKER	TP05	EA	

REAR SELECTION - Estimated Lift 40mm

LWB MODEL		Part Number	Qty	Note
Medium Load	Leaf Spring	CS039R	2	2
	Shock - N/Charger	OME035		
Constant 100kg	Leaf Spring	CS039R	2	2
	Extra Leaf	D21XL		4
	Shock - N/Charger	OME035		

REAR SELECTION - Estimated Lift 40mm

SWB MODEL		Part Number	Qty	Note
Medium Load	Leaf Spring	CS038R	2	2
	Shock - N/Charger	OME035		
Constant 100kg	Leaf Spring	CS039R	2	2
	Shock - N/Charger	OME035		

FIT KITS & HARDWARE

Loc	Description	Part Number	Qty	Note
R	SPRING BUSH	OMESB19	2	
R	CENTRE BOLT			5
R	TRIM PACKER	TP05	EA	
R	U BOLT	OMEU60	4	2

FRONT SELECTION

V6 DIESEL ENGINE		Part Number	Qty	Notes	
Estimated Lift 40-50mm	No Bar	Spring	3215	1 2	
		Strut - N/Sport	90054	2 3	
	Bar Only	Spring	3216	1 2	
		Strut - N/Sport	*90055 / 90054	2 3	
	Bar/ Winch	Spring	3217	1 2	
		Strut - N/Sport	90055	2 3	
	Bar/ Winch/ Accessories	Spring	3218	1 2	
		Strut - N/Sport	90055	2 3	
	Nitro +	Spring	4023	1 2	
		Strut	*93055 / 93054	2 3,4	
	BP-51 - NOT GR SPORT	Strut - RH	BP5190019R	1+1	
		Strut - LH	BP5190019L		
		Fit Kit	VM80010054	1	
	BP-51 - GR SPORT ONLY	Strut - RH	BP5190022R	1+1	
Strut - LH		BP5190022L			
Fit Kit		VM80010066	1		

Comments

- 1** OME661 lower shock stone guards are recommended fitment for protection against stone damage.
- 2** OME coils and struts can only be installed together due to different winding of the lower coil end to suit the OME coil seat. They are not compatible with the OE coil seat.
- 3** No top bushes supplied. Re-use OE Bushes.
- 4** Does not suit OE coil

FRONT SELECTION

V6 DIESEL ENGINE		Part Number	Qty	Notes	
Estimated Lift 20mm	No Bar	Spring	3304	1 2	
		Strut - N/Sport	90054	2 3	
	Bar Only	Spring	3224	1 2	
		Strut - N/Sport	*90055 / 90054	2 3	
	Bar/ Winch	Spring	3215	1 2	
		Strut - N/Sport	90055	2 3	
	Bar/ Winch/ Accessories	Spring	3216	1 2	
		Strut - N/Sport	90055	2 3	
	Nitro +	Spring	4038	1 2	
		Strut	*93055 / 93054	2 3,4	
	BP-51 - NOT GR SPORT	Strut - RH	BP5190019R	1+1	
		Strut - LH	BP5190019L		
		Fit Kit	VM80010054	1	
	BP-51 - GR SPORT ONLY	Strut - RH	BP5190022R	1+1	
Strut - LH		BP5190022L			
Fit Kit		VM80010066	1		

FIT KITS & HARDWARE

Loc	Description	Part Number	Qty	Note
F	UPPER CONTROL ARMS	UCA0006	1	
F	TRIM PACKER	OME95PF5	EA	

FRONT SELECTION

PETROL ENGINE		Part Number	Qty	Notes	
Estimated Lift 40-50mm	No Bar	Spring	3224	1 2	
		Strut - N/Sport	90054	2 3	
	Bar Only	Spring	3215	1 2	
		Strut - N/Sport	*90055 / 90054	2 3	
	Bar/ Winch	Spring	3216	1 2	
		Strut - N/Sport	90055	2 3	
	Bar/ Winch/ Accessories	Spring	3217	1 2	
		Strut - N/Sport	90055	2 3	
	Nitro +	Spring	4022	1 2	
		Strut	*93055 / 93054	2 3,4	
	BP-51 - NOT GR SPORT	Strut - RH	BP5190019R	1+1	
		Strut - LH	BP5190019L		
		Fit Kit	VM80010054	1	
	BP-51 - GR SPORT ONLY	Strut - RH	BP5190022R	1+1	
Strut - LH		BP5190022L			
Fit Kit		VM80010066	1		

Comments

- 1 OME661 lower shock stone guards are recommended fitment for protection against stone damage.
- 2 OME coils and struts can only be installed together due to different winding of the lower coil end to suit the OME coil seat. They are not compatible with the OE coil seat.
- 3 No top bushes supplied. Re-use OE Bushes.
- 4 Does not suit OE coil

FRONT SELECTION

PETROL ENGINE		Part Number	Qty	Notes	
Estimated Lift 20mm	No Bar	Spring	3310	1 2	
		Strut - N/Sport	90054	2 3	
	Bar Only	Spring	3304	1 2	
		Strut - N/Sport	*90055 / 90054	2 3	
	Bar/ Winch	Spring	3224	1 2	
		Strut - N/Sport	90055	2 3	
	Bar/ Winch/ Accessories	Spring	3215	1 2	
		Strut - N/Sport	90055	2 3	
	Nitro +	Spring	4039	1 2	
		Strut	*93055 / 93054	2 3,4	
	BP-51 - NOT GR SPORT	Strut - RH	BP5190019R	1+1	
		Strut - LH	BP5190019L		
		Fit Kit	VM80010054	1	
	BP-51 - GR SPORT ONLY	Strut - RH	BP5190022R	1+1	
Strut - LH		BP5190022L			
Fit Kit		VM80010066	1		

FIT KITS & HARDWARE

Loc	Description	Part Number	Qty	Note
F	UPPER CONTROL ARMS	UCA0006	1	
F	TRIM PACKER	OME95PF5	EA	

REAR SELECTION

ALL MODELS		Part Number	Qty	Note
Estimated Lift 50mm	Medium Load	Spring	3219	1
		Shock - N/Sport	60176	2
		Shock - N/Plus	63176	1
	Constant 200kg	Spring	3220	1
		Shock - N/Sport	*60177 / 60176	2
		Shock - N/Plus	*63177 / 63176	1
	Constant 400kg	Spring	3221	1
		Shock - N/Sport	60177	2
		Shock - N/Plus	63177	1
	Constant 600kg	Spring	3222	1
		Shock - N/Sport	60177	2
		Shock - N/Plus	63177	1
	BP-51	Shock - All Models	*BP5160062 / BP5160061	2
		Fit Kit (Not GR)	VM80010055	1
		Fit Kit (GR ONLY)	VM80010067	1

Comments

- 1** OME661 lower shock stone guards are recommended fitment for protection against stone damage.
- 2** OME coils and struts can only be installed together due to different winding of the lower coil end to suit the OME coil seat. They are not compatible with the OE coil seat.
- 3** No top bushes supplied. Re-use OE Bushes.

REAR SELECTION

ALL MODELS		Part Number	Qty	Note
Estimated Lift 20mm	Medium Load	Spring	3311	1
		Shock - N/Sport	60176	2
		Shock - N/Plus	63176	1
	Constant 200kg	Spring	3312	1
		Shock - N/Sport	*60177 / 60176	2
		Shock - N/Plus	*63177 / 63176	1
	Constant 400kg	Spring	3313	1
		Shock - N/Sport	60177	2
		Shock - N/Plus	63177	1
	Constant 600kg	Spring	3314	1
		Shock - N/Sport	60177	2
		Shock - N/Plus	63177	1
	BP-51	Shock - All Models	*BP5160062 / BP5160061	2
		Fit Kit (Not GR)	VM80010055	1
		Fit Kit (GR ONLY)	VM80010067	1

FIT KITS & HARDWARE

Loc	Description	Part Number	Qty	Note
R	TRIM PACKER	OME80PR05	EA	
		OME80PR10		
R	STONE GUARD KIT	OME661	1	1

FRONT SELECTION

V8 DIESEL ENGINE		Part Number	Qty	Notes
Est Lift 50mm	No Bar	Spring	2702	1 1
		Strut - N/Sport	90017	2 1,3
	Bar Only	Spring	2703	1 1
		Strut - N/Sport	91005	2 1,3
Bar/ Winch/ Accessories	Spring	2703	1 1	
	Strut - N/Sport	91005	2 1,3	
Nitro +	Spring	4008	1 1	
	Shock	*93005 / 93017	2 1,3,7	
Est Lift 25mm	No Bar	Spring	2700	1 1
		Strut - N/Sport	90017	2 1,3
	Bar Only	Spring	2701	1 1
		Strut - N/Sport	91005	2 1,3
Bar/ Winch/ Accessories	Spring	2701	1 1	
	Strut - N/Sport	91005	2 1,3	
Nitro +	Spring	4010	1 1	
	Strut	*93005 / 93017	2 1,3,7	
50mm	BP-51	Coilover LH	BP5190003L	1+1 1
		Coilover RH	BP5190003R	
		Fit Kit	VM80010003	1 1,3

FIT KITS & HARDWARE

Loc	Description	Part Number	Qty	Note
F	UPPER CONTROL ARM	UCA0001	1	6
F	UPPER STRUT BUSHES	OME3125	2	3
F	COIL PACKER	OME95PF5	EA	2
F	STRUT TOP HAT KIT	OMETH003	2	4
F	FRONT AXLE UPGRADE LABEL KIT	FAU2001870	1	5

SERVICE PARTS

Loc	Description	Part Number	Qty	Note
F	OME UCA Eye Bush 2pk	UCASP001	1	
F	OME UCA Ball Joint 1pk	UCASP002	EA	
F	OME UCA Boot 2pk	UCASP003	1	

Selection Hints

For fitment to Models with Toyota's KDSS (Kinetic Dynamic Suspension System) fitted, please refer to OME's Fitting Hints & Tips (OME Bulletin 70 LC200 KDSS Fitting Hints).

Comments

- 1** OME coils and struts can only be installed together due to different winding of the lower coil end to suit the OME coil seat. They are not compatible with the OE coil seat. Due to the nature of the KDSS, Models fitted with KDSS may experience a characteristic 10mm to 15mm lean to the front right hand side.
- 2** To maintain ride height when front accessory weight exceeds 100kgs, OME95PF5 Coil Packer should be installed, each OME95PF5 will increase ride height by 10mm.
- 3** No top mounting bushes supplied, use OME3125. OE bushes may be re-used if in good condition
- 4** Strut Top Hat Kit may be required if original equipment is worn.
- 5** Australia Only. Full OME suspension system must be fitted.
- 6** The OME Upper Control Arm will provide an increase between +2.5 and +3.5 degrees of caster and up to 1.5 degrees of negative camber increase (figures based off an approximate 50mm lift). Please note after fitment of Upper Control Arm a vehicle wheel alignment will be required.
- 7** Does not suit OE coil.

FRONT SELECTION

V8 PETROL ENGINE		Part Number	Qty	Notes
Est Lift 50mm	No Bar	Spring	2700	1 1
		Strut - N/Sport	90017	2 1,3
	Bar Only	Spring	2701	1 1
		Strut - N/Sport	91005	2 1,3
Bar/ Winch/ Accessories	Spring	2701	1 1	
	Strut - N/Sport	91005	2 1,3	
Nitro +	Spring	4010	1 1	
	Strut	*93005 / 93017	2 1,3,7	
Est Lift 25mm	No Bar	Spring	2704	1 1
		Strut - N/Sport	90017	2 1,3
	Bar Only	Spring	2705	1 1
		Strut - N/Sport	91005	2 1,3
Bar/ Winch/ Accessories	Spring	2705	1 1	
	Strut - N/Sport	91005	2 1,3	
Nitro +	Spring	4019	1 1	
	Strut	*93005 / 93017	2 1,3,7	
50mm	BP-51	Coilover LH	BP5190003L	1+1
		Coilover RH	BP5190003R	
		Fit Kit	VM80010003	1

FIT KITS & HARDWARE

Loc	Description	Part Number	Qty	Note
F	UPPER CONTROL ARM	UCA0001	1	6
F	UPPER STRUT BUSHES	OME3125	2	3
F	COIL PACKER	OME95PF5	EA	2
F	STRUT TOP HAT KIT	OMETH003	2	4
F	FRONT AXLE UPGRADE LABEL KIT	FAU2001870	1	5

SERVICE PARTS

Loc	Description	Part Number	Qty	Note
F	OME UCA Eye Bush 2pk	UCASP001	1	
F	OME UCA Ball Joint 1pk	UCASP002	EA	
F	OME UCA Boot 2pk	UCASP003	1	

Selection Hints

For fitment to Models with Toyota's KDSS (Kinetic Dynamic Suspension System) fitted, please refer to OME's Fitting Hints & Tips (OME Bulletin 70 LC200 KDSS Fitting Hints).

Comments

- 1** OME coils and struts can only be installed together due to different winding of the lower coil end to suit the OME coil seat. They are not compatible with the OE coil seat. Due to the nature of the KDSS, Models fitted with KDSS may experience a characteristic 10mm to 15mm lean to the front right hand side.
- 2** To maintain ride height when front accessory weight exceeds 100kgs, OME95PF5 Coil Packer should be installed, each OME95PF5 will increase ride height by 10mm.
- 3** No top mounting bushes supplied, use OME3125. OE bushes may be re-used if in good condition
- 4** Strut Top Hat Kit may be required if original equipment is worn.
- 5** Australia Only. Full OME suspension system must be fitted.
- 6** The OME Upper Control Arm will provide an increase between +2.5 and +3.5 degrees of caster and up to 1.5 degrees of negative camber increase (figures based off an approximate 50mm lift). Please note after fitment of Upper Control Arm a vehicle wheel alignment will be required.
- 7** Does not suit OE coil.

REAR SELECTION

ALL MODELS		Part Number	Qty	Note
Estimated Lift 20mm	Medium Load	Spring	2722	1
		Spring KDSS	3185	
		Shock - N/Sport	61029	2
		Shock - N/Plus	63029	
	Constant 200kg	Spring	2723	1
		Spring KDSS	3186	
		Shock - N/Sport	61030	2
		Shock - N/Plus	63030	
	Constant 400kg	Spring	2724	1
		Spring KDSS	3187	
		Shock - N/Sport	61030	2
		Shock - N/Plus	63030	
Constant 600kg	Spring	2725	1	
	Spring KDSS	3188		
	Shock - N/Sport	61030	2	
	Shock - N/Plus	63030		
No Lift	Medium Load	Spring	2721	1
		Shock - N/Sport	61029	2
		Shock - N/Plus	63029	
-20mm	Medium Load	Spring	2720	1
		Shock - N/Sport	61029	2
		Shock - N/Plus	63029	
20mm	BP-51	Shock	BP5160026	2
		Shock	*BP5160053	
		Fit Kit	VM80010004	1
		Fit Kit - KDSS	VM80010005	

Selection Hints

For fitment to Models with Toyota's KDSS (Kinetic Dynamic Suspension System) fitted, please refer to OME's Fitting Hints & Tips (OME Bulletin 70 LC200 KDSS Fitting Hints).

Comments

- 1 OME661 Lower Shock Stone Guards are recommended fitment for protection against stone damage.
- 2 Not suitable for KDSS Models.

FIT KITS & HARDWARE

Loc	Description	Part Number	Qty	Note
R	TRIM PACKER	OME80PR05	EA	
		OME80PR10		
R	STONE GUARD KIT	OME661	1	1
R	SWAY BAR UPGRADE (33mm)	OMESTAB5		2

FRONT SELECTION

PETROL & DIESEL ENGINE		Part Number	Qty	Notes
Est Lift 50mm	No Bar	Spring	2851	1
		Shock - N/Sport	60018	2
	Bar Only	Shock - N/Plus	63018	2
		Spring	2850	1
	Bar/ Winch/ Accessories	Shock - N/Sport	*60070 / 60018	2
		Shock - N/Plus	*63070 / 63018	2
Est lift 10mm	Bar Only	Spring	2861	1
		Shock - N/Sport	60070	2
		Shock - N/Plus	63070	2
	Bar/ Winch/ Accessories	Spring	2861	1
		Shock - N/Sport	60070	2
		Shock - N/Plus	63070	2
50mm	BP-51	Shock	BP5160043	2
		Fit Kit	VM80010025	1

Comments

- 1** OMECA77B Caster Kit will increase caster angle by 2 degrees. Check manufacturer's specifications to determine if OMECA77B Caster Kit is required.
- 2** Packers must be installed on the top of coil springs.
- 3** OME662 or OME661 Lower Shock Mount Stone Guard is recommended fitment to protect against severe stone pepping encountered on loose road surfaces. OME662 will only fit Models with 34mm diameter control arms.

FIT KITS & HARDWARE

Loc	Description	Part Number	Qty	Note
F	TRIM PACKER	OME80PF05	EA	2
		OME80PF10		
F	STEERING DAMPER	OMESD24	1	
F	CASTER KIT	OMECA77B	1	1

REAR SELECTION

ALL MODELS		Part Number	Qty	Note	
Estimated Lift	Medium Load	Spring	2860	1	
		Shock - N/Sport	60020	2	2,3
		Shock - N/Plus	63020		
	Constant 200kg	Spring	2863	1	
		Shock - N/Sport	60020	2	2,3
		Shock - N/Plus	63020		
	Constant 400kg	Spring	2864	1	
		Shock - N/Sport	60071	2	2,3
		Shock - N/Plus	63071		
	Constant 600kg	Spring	2868	1	
		Shock - N/Sport	60071	2	2,3
		Shock - N/Plus	63071		
20mm	Medium Load	Spring	2862	1	
		Shock - N/Sport	60020	2	2,3
		Shock - N/Plus	63020		
50mm	BP-51	Shock	BP5160013	2	
		Fit Kit	VM80010026	1	

Comments

- 1** OMECA77B Caster Kit will increase caster angle by 2 degrees. Check manufacturer's specifications to determine if OMECA77B Caster Kit is required.

- 2** Packers must be installed on the top of coil springs.

- 3** OME662 or OME661 Lower Shock Mount Stone Guard is recommended fitment to protect against severe stone peppering encountered on loose road surfaces. OME662 will only fit Models with 34mm diameter control arms.

REAR SELECTION

LPG CONVERSIONS		Part Number	Qty	Note	
Estimated Lift	Medium Load	Spring	2860	1	
		Shock - N/Sport	60020	2	2,3
		Shock - N/Plus	63020		
	Constant 200kg	Spring	2863	1	
		Shock - N/Sport	60020	2	2,3
		Shock - N/Plus	63020		
	BP-51	Shock	BP5160013	2	
		Fit Kit	VM80010026	1	

FIT KITS & HARDWARE

Loc	Description	Part Number	Qty	Note
R	TRIM PACKER	OME80PR05	EA	2
		OME80PR10		
R	STONE GUARD KIT	OME661	1	3
		OME662		

FRONT SELECTION

ALL LWB MODELS		Part Number	Qty	Notes
Bar Only	Spring - 75mm	2418	1	
	Spring - 100mm	2419		
	Spring - 125mm	2420		
Bar/ Winch/ Accessories	Spring - 75mm	3039	1	
	Spring - 100mm	3051		
Nitrocharger Sport	Shock (100mm)	60018L	2	1
		*60070L		
Nitrocharger Plus	Shock (100mm)	63018L	2	1
		*63070L		
BP-51	Shock (100mm)	BP5160044	2	1
	Fit Kit	VM80010025	1	

Lift increase is approximate and will depend on vehicle weights.

Modifications for off road use only.

The products listed in this selection chart are deemed by Old Man Emu to be suitable for off road use and their legality for public road use should be certified by the relevant Registration Authority. An Off Road Use Only Disclaimer must be signed by the customer.

Modifications and replacement of other associated components will be required.

Warranty will be void if the shocks have been used in a racing application.

FIT KITS & HARDWARE

Loc	Description	Part Number	Qty	Note
F	STEERING DAMPER	OMESD24	1	
F	ADJ PANHARD ROD	PAN3050		
		PANR007		
F	TRIM PACKER	OME80PF05	EA	3
		OME80PF10		

Comments

REAR SELECTION

ALL LWB MODELS		Part Number	Qty	Notes
Medium Load	Spring - 75mm	2421	1	
	Spring - 100mm	2422		
	Spring - 125mm	2423		
Constant 200kg	Spring - 75mm	3040	1	
	Spring - 100mm	3043		
Constant 400kg	Spring - 75mm	3049	1	
	Spring - 100mm	3052		
Nitrocharger Sport	Shock (100mm)	60020L	2	1
		*60071L		
Nitrocharger Plus	Shock (100mm)	63020L	2	1
		*63071L		
BP-51	Shock (100mm)	BP5160015	2	1
	Fit Kit	VM80010026	1	

1 Shocks are designed around a 100mm coil - compatiability for 75mm & 125mm need to be determined by the installer with open and closed lengths checked as well as bump stop contact measurements.

2 PANR007 suits RHD only
 PAN3050 suits LHD only
 PANR008 suits RHD & LHD
 LTA3043 - Standard Length
 UTA3036 - 40mm on car adjustable

3 Coil trim packers may be required to trim vehicles. Rear Packers must be installed to the top of the coil tower only.
 OME80PF05 - 5mm
 OME80PF10 - 10mm

FIT KITS & HARDWARE

Loc	Description	Part Number	Qty	Note
R	ADJ PANHARD ROD	PANR008	1	2
R	H/DUTY LOWER TRAILING ARMS	LTA3043		
R	ADJ UPPER TRAILING ARMS	UTA3036		
R	TRIM PACKER	OME80PR05	EA	3
		OME80PR10		

FRONT SELECTION

PETROL & DIESEL MODELS		Part Number	Qty	Note
Bar/ Winch/ Accessories	Torsion Bars	303001	1	1
		303002		
	Shock - N/Sport	*60001 / 60000	2	
		*63001 / 63000		

Comments

1 Raise or lower front end clearance and trim vehicle by adjusting front torsion bars. It is **important** that a minimum of 60mm of droop is maintained to prevent topping out of the front shock absorbers. 303001 suits V8 Models, 303002 suits Turbo Diesel Models.

2 Packers must be installed on top of coils.

3 SPORT/NITROCHARGER FITMENT: OME661 or OME662 (suits 40mm diameter control arms) Lower Shock Mount Stone Guard is recommended fitment to rear shocks to protect against severe stone pepping encountered on loose road surfaces.

4 Original rear rake is 60mm approximately with OE coil rates of 145lbs/in or 25.5N/mm. Customers wishing to lower the rear height but increase the load carrying ability can select from:

2866 - Reduces OE height by 10mm (rates 240 - 300lbs/in, 42 - 52.5N/mm)

2862 - Reduces OE height by 30mm (rates 240lbs/in, 42N/mm)

5 Due to the common problem of the lower control arm cracking when driven under hard conditions, the fitment of a FK27 Lower Control Arm Reinforcing Bracket Kit is strongly recommended.

FIT KITS & HARDWARE

Loc	Description	Part Number	Qty	Note
F	UPPER CONTROL ARM	UCA0010	1	5
F	FITTING KIT	FK27		

REAR SELECTION

ALL MODELS 10/2000 ON		Part Number	Qty	Note	
Estimated Lift 10mm	Medium Load	Spring	2860	1	
		Shock - N/Sport	60002	2	2
			63002		
	Constant 200kg	Spring	2863	1	
		Shock - N/Sport	*60003 / 60002	2	
			*63003 / 63002		
Constant 400kg	Spring	2864	1		
	Shock - N/Sport	60003	2		
		63003			
REAR RAKE	Medium Load	Spring	2866	1	4
		Spring	2862		
		Shock - N/Sport	60002	2	
			Shock - N/Plus		

REAR SELECTION

ALL MODELS 10/98 TO 09/2000		Part Number	Qty	Note	
Est Lift 40mm	Medium Load	Spring	2865	1	
		Shock - N/Sport	60002	2	2
			63002		
	Constant 200kg	Spring	2866	1	
		Shock - N/Sport	*60003 / 60002	2	
*63003 / 63002					

FIT KITS & HARDWARE

Loc	Description	Part Number	Qty	Note
R	TRIM PACKER	OME80PR05	EA	2
		OME80PR10		
R	STONE GUARD KIT	OME661	1	3
		OME662		

FRONT SELECTION

V8 DIESEL ENGINE		Part Number	Qty	Note	
Estimated Lift 40mm	No Bar	Spring	2859	1	3
		Shock - N/Sport	60008	2	2
		Shock - N/Plus	63008		
	Bar Only	Spring	2853	1	3
		Shock - N/Sport	60008	2	2
		Shock - N/Plus	63008		
	Bar/ Winch/ Accessories	Spring	2853	1	3
		Shock - N/Sport	60008	2	2
		Shock - N/Plus	63008		
	MT64	Shock	MT64601003	2	
	BP-51	Shock	BP5160042	2	
		Fit Kit	VM80010006	1	

Comments

- 1** OMECA77B Caster Kit will increase caster angle by 2 degrees. Check manufacturer's specifications to determine if required.
- 2** Should the front drive shaft contact the sway bar when the suspension is at full droop, use FK19 Spacer Kit to pack the sway bar down.
- 3** For heavily loaded applications it may be necessary to step down one spring selection in the front to maintain correct rake.
- 4** For vehicles fitted with ABS brakes. FK65 fit kit is required for vehicles prior to August 2016 production. For vehicles post August 2016 production refer to PIB No 343 for instructions on adjustment.
- 5** Australia Only. Full OME Suspension System must be fitted.
- 6** OMESTAB3 suits V8 Diesel engines only.

FIT KITS & HARDWARE

Loc	Description	Part Number	Qty	Note
F	STEERING DAMPER	OMESD47	1	
F	CASTER KIT	OMECA77B		1
F	SWAY BAR SPACER KIT	FK19		2
F	UPGRADED FRONT SWAY BAR	OMESTAB3		6
F	ABS WIRE BRACKET KIT	FK65		4
F	FRONT AXLE UPGRADE LABEL KIT	FAU701540		5
F	TRIM PACKER	OME79PF10		EA

FRONT SELECTION

PETROL & DIESEL 6 CYL ENGINES		Part Number	Qty	Note	
Estimated Lift 40mm	No Bar	Spring	2856	1	3
		Shock - N/Sport	60008	2	2
		Shock - N/Plus	63008		
	Bar Only	Spring	2859	1	3
		Shock - N/Sport	60008	2	2
		Shock - N/Plus	63008		
	Bar/ Winch/ Accessories	Spring	2859	1	3
		Shock - N/Sport	60008	2	2
		Shock - N/Plus	63008		
	MT64	Shock	MT64601003	2	
	BP-51	Shock	BP5160042	2	
		Fit Kit	VM80010006	1	

FIT KITS & HARDWARE

Loc	Description	Part Number	Qty	Note
F	STEERING DAMPER	OMESD24	1	
F	CASTER KIT	OMECA77B		1
F	SWAY BAR SPACER KIT	FK19		2
F	ABS WIRE BRACKET KIT	FK65		4
F	FRONT AXLE UPGRADE LABEL KIT	FAU701540		5
F	TRIM PACKER	OME79PF10		EA

REAR SELECTION

ALL MODELS		Part Number	Qty	Note	
Estimated Lift 45mm	Medium Load	Multi Leaf Spring	EL113R	2,4,9	
	Shocks	Nitro Sport	60010	2	
		Nitro Plus	63010		
		MT64	MT64601005		
	Constant 300kg	Multi Leaf Spring	EL114R	2,4,9	
	Constant 400kg	Parabolic Spring	PB007R	2,4,7,8	
	Shocks	Nitro Sport	60011	2	
		Nitro Plus	63011		
		MT64	MT64601006		
	Constant 500kg	Multi Leaf Spring	EL115R	2,4,9	
	Constant 600kg	Parabolic Spring	PB008R	2,4,7,8	
	Shocks	Nitro Sport	60011	2	
		Nitro Plus	63011		
		MT64	MT64601006		
	Constant 700kg	Multi Leaf Spring	EL116R	2,3,4,5,9	
	Shocks	Nitro Sport	60109	2	
		Nitro Plus	63109		
		MT64	MT64601008		
Constant 800kg	Parabolic Spring	PB009R	2,3,4,7,8		
Constant 1000kg	Parabolic Spring	PB010R			
Shocks	Nitro Plus	63401	2		
	MT64	MT64601006			
BP-51	Shock	BP5160028	2	6	
	Shock Long	BP5160052			
	Fit Kit	VM80010007	1		
AIR BAG KIT		OMEAB003	1	10	
SPRING BUSH KIT		OMESB101	2	1	
		OMESB85			
GREASABLE SHACKLE KIT		OMEGS10	1		
GREASABLE FIXED END PIN KIT		OMEGP7			
U BOLT		OMEU59B	4	5	
		OMEU59C			
		OMEU59D			
BRAKE PROPORTIONING VALVE		FK51	1	4	
		FK58			

Comments

- 1 OMESB101: Use on original shackles & pins. OMESB85: Use for all Models when installing OME greasable shackles & pins.
- 2 Include tray weight in constant load calculation.
- 3 OMESTAB9 Sway Bar is highly recommended fitment when 700kg Constant Spring is used. Sway Bar can also be fitted to lighter rated springs to improve road handling. FK76 suits Models with OE axle sway bar mount. FK77 suits Models without OE sway bar provision.
- 4 FK51 and FK58 Brake Proportioning Valve Kits (included in BP-51 Fit Kit) suit vehicles prior to August 2016 production. FK51 is for medium load and 300kg spring. FK58 is for 500kg and 700kg spring. Due to variance in tray clearance on 70 Series Dual Cab please check vehicle before selecting Fit Kit.
- 5 Use OMEU59C if fitting Extra Leaf to EL116R. Use OMEU59D for parabolic leaf springs.
- 6 Suits EL116R **Only**.
- 7 When fitting parabolic springs to a vehicle with a rear sway bar, the mount plate may contact the sway bar & will need to be spaced down with 2 x ELSK06 & 1 x UCB17
- 8 Air Bag Kit is a **mandatory** fitment.
- 9 Air Bag Kit is **not recommended** for Multi-Leaf Springs.
- 10 Refer to **Leaf Spring Service Parts** section for Centre Bolt selection.
- 11 Required for models 2014 to 08/16.
- 12 Does not suit parabolic springs

FIT KITS & HARDWARE

Loc	Description	Part Number	Qty	Note
R	SWAY BAR	OMESTAB9	1	3
R	SWAY BAR FIT KIT	FK77		
		FK76		
R	REAR BRAKE LINE DROP	FK82	2	11
R	EXTRA LEAF	EL14XL		
R	EXTRA LEAF SPACER KIT	ELSK13	EA	10
R	CENTRE BOLT			
R	TRIM PACKER	ELSK06		

FRONT SELECTION

V8 DIESEL ENGINE		Part Number	Qty	Note	
Estimated Lift 50mm	No Bar	Spring	2856	1	3,4
		Shock - N/Sport	60008	2	
		Shock - N/Plus	63008		
	Bar Only	Spring	2859	1	3,4
		Shock - N/Sport	60008	2	
		Shock - N/Plus	63008		
	Bar/ Winch/ Accessories	Spring	2859	1	3,4
		Shock - N/Sport	60008	2	
		Shock - N/Plus	63008		
	MT64	Shock	MT64601003	2	
	BP-51	Shock	BP5160042	2	
		Fit Kit	VM80010006	1	

Comments

- 1** OMECA77B Caster Kit will increase caster angle by 2 degrees. Check manufacturer's specifications to determine if required.
- 2** Should the front drive shaft contact the sway bar when the suspension is at full droop, use FK19 Spacer Kit to pack the sway bar down.
- 3** For vehicles fitted with ABS brakes. FK65 fit kit is required for vehicles prior to August 2016 production. For vehicles post August 2016 production refer to PIB No 343 for instructions on adjustment.
- 4** For heavily loaded applications it may be necessary to step down one spring selection in the front to maintain correct rake.
- 5** Australia Only. Full OME Suspension System must be fitted.
- 6** Be sure to select OME Bush Kits carefully:
OMESB85: Use for all Models when installing OME greasable shackles & pins.
OMESB86: Use when original shackles & pins are used.
- 7** To prevent springs from inverting it is mandatory that either OMEGS19 Greasable Shackle Kit or FK38 Anti Inversion Kit be installed.
- 8** OME661 Lower Shock Mount Stone Guard Kit is recommended fitment to rear shocks to protect against severe stone peppering encountered on loose road surfaces.
- 9** FK51 and FK58 Brake Proportioning Valve Kits (included in BP-51 Fit Kit) suit vehicles prior to August 2016 production. FK51 is for medium load. FK58 is for 400kg and 800kg Spring.
- 10** Use OMEU59B when fitting CS070R springs.
- 11** Does not fit with CS070R.
- 12** Refer to **Leaf Spring Service Parts** section for Centre Bolt selection.

FIT KITS & HARDWARE

Loc	Description	Part Number	Qty	Note
F	STEERING DAMPER	OMESD47	1	
F	CASTER KIT	OMECA77B		1
F	SWAY BAR SPACER KIT	FK19		2
F	ABS WIRE BRACKET KIT	FK65		
F	UPGRADED FRONT SWAY BAR	OMESTAB3		3
F	FRONT AXLE UPGRADE LABEL KIT	FAU701540		5

REAR SELECTION

ALL MODELS		Part Number	Qty	Note	
Estimated Lift 50mm	Medium Load	Leaf Spring	CS057R	9	
		Shock - N/Sport	60010	8,3	
		Shock - N/Plus	63010		
		Shock - MT64	MT64601005		
	Constant 400kg	Leaf Spring	CS058R	9	
		Shock - N/Sport	*60111 / 60011	8,3	
		Shock - N/Plus	*63111 / 63011		
		Shock - MT64	MT64601006		
	Constant 800kg	Leaf Spring	CS070R	9,10	
		Shock - N/Sport	60111	8,3	
		Shock - N/Plus	63111		
		Shock - MT64	MT64601006		
	BP-51	Shock	BP5160028	2	
		Fit Kit	VM80010007	1	
	SPRING BUSH KIT		OMESB86	2	6
			OMESB85		
	GREASABLE SHACKLE KIT		OMEGS19	1	7
	GREASABLE FIXED END PIN KIT		OMEGP7		
U BOLT		OMEU59D	4	10	
		OMEU59B			
BRAKE PROPORTIONING BRKT		FK51	1	9	
		FK58			
REAR BRAKE LINE DROP		FK82			

FIT KITS & HARDWARE

Loc	Description	Part Number	Qty	Note
R	ANTI-INVERSION KIT	FK38	1	7
R	STONE GUARD KIT	OME661		8
R	EXTRA LEAF	D35XL	2	11
R	EXTRA LEAF SPACER KIT	ELSK13		
R	CENTRE BOLT			12

Comments

- 1** OMECA77B Caster Kit will increase caster angle by 2 degrees. Check manufacturer's specifications to determine if required.
- 2** Should the front drive shaft contact the sway bar when the suspension is at full droop, use FK19 Spacer Kit to pack the sway bar down.
- 3** For vehicles fitted with ABS brakes. FK65 fit kit is required for vehicles prior to August 2016 production. For vehicles post August 2016 production refer to PIB No 343 for instructions on adjustment.
- 4** For heavily loaded applications it may be necessary to step down one spring selection in the front to maintain correct rake.
- 5** Australia Only. Full OME Suspension System must be fitted.
- 6** Be sure to select OME Bush Kits carefully:
OMESB85: Use for all Models when installing OME greasable shackles & pins.
OMESB86: Use when original shackles & pins are used.
- 7** To prevent springs from inverting it is mandatory that either OMEGS19 Greasable Shackle Kit or FK38 Anti Inversion Kit be installed.
- 8** OME661 Lower Shock Mount Stone Guard Kit is recommended fitment to rear shocks to protect against severe stone peppering encountered on loose road surfaces.
- 9** FK51 and FK58 Brake Proportioning Valve Kits (included in BP-51 Fit Kit) suit vehicles prior to August 2016 production. FK51 is for medium load. FK58 is for 400kg and 800kg Spring.
- 10** Use OMEU59B when fitting CS070R springs.
- 11** Does not fit with CS070R.
- 12** Refer to **Leaf Spring Service Parts** section for Centre Bolt selection.

FRONT SELECTION

V8 DIESEL ENGINE		Part Number	Qty	Note	
Estimated Lift 40mm	No Bar	Spring	2859	1	3,4
		Shock - N/Sport	60008	2	
		Shock - N/Plus	63008		
	Bar Only	Spring	2853	1	3,4
		Shock - N/Sport	60008	2	
		Shock - N/Plus	63008		
	Bar/ Winch/ Accessories	Spring	2853	1	3,4
		Shock - N/Sport	60008	2	
		Shock - N/Plus	63008		
	MT64	Shock	MT64601003	2	
	BP-51	Shock	BP5160042	2	
		Fit Kit	VM80010006	1	

Comments

- 1** OMECA77B Caster Kit will increase caster angle by 2 degrees. Check manufacturer's specifications to determine if required.
- 2** Should the front drive shaft contact the sway bar when the suspension is at full droop, use FK19 Spacer Kit to pack the sway bar down.
- 3** For vehicles fitted with ABS brakes. FK65 fit kit is required for vehicles prior to August 2016 production. For vehicles post August 2016 production refer to PIB No 343 for instructions on adjustment.
- 4** For heavily loaded applications it may be necessary to step down one spring selection in the front to maintain correct rake.
- 5** Australia Only. Full OME Suspension System must be fitted.

FIT KITS & HARDWARE

Loc	Description	Part Number	Qty	Note
F	STEERING DAMPER	OMESD47		
F	CASTER KIT	OMECA77B	1	1
F	SWAY BAR SPACER KIT	FK19		2
F	TRIM PACKER	OME79PF10	EA	
F	UPGRADED FRONT SWAY BAR	OMESTAB3		
F	ABS WIRE BRACKET KIT	FK65	1	3
F	FRONT AXLE UPGRADE LABEL KIT	FAU701540		5

FRONT SELECTION

PETROL & 6CYL DIESEL ENGINE		Part Number	Qty	Note	
Estimated Lift 40mm	No Bar	Spring	2856	1	3,4
		Shock - N/Sport	60008	2	
		Shock - N/Plus	63008		
	Bar Only	Spring	2859	1	3,4
		Shock - N/Sport	60008	2	
		Shock - N/Plus	63008		
	Bar/ Winch/ Accessories	Spring	2859	1	3,4
		Shock - N/Sport	60008	2	
		Shock - N/Plus	63008		
	MT64	Shock	MT64601003	2	
	BP-51	Shock	BP5160042	2	
		Fit Kit	VM80010006	1	

FIT KITS & HARDWARE

Loc	Description	Part Number	Qty	Note
F	STEERING DAMPER	OMESD24		
F	CASTER KIT	OMECA77B	1	1
F	SWAY BAR SPACER KIT	FK19		2
F	TRIM PACKER	OME79PF10	EA	
F	ABS WIRE BRACKET KIT	FK65	1	3
F	FRONT AXLE UPGRADE LABEL KIT	FAU701540		5

REAR SELECTION

ALL MODELS		Part Number	Qty	Note
Estimated Lift 45mm	Constant 200kg	Multi Leaf Spring	EL113R	2,4
		Shock - N/Sport	60010	2
		Shock - N/Plus	63010	
		Shock - MT64	MT64601005	
	Constant 400kg	Multi Leaf Spring	EL114R	2,4
		Parabolic Spring	PB007R	2,4,9
		Shock - N/Sport	60011	2
		Shock - N/Plus	63011	
		Shock - MT64	MT64601006	
	Constant 600kg	Multi Leaf Spring	EL115R	2,4
		Parabolic Spring	PB008R	2,4,9
		Shock - N/Sport	60011	2
		Shock - N/Plus	63011	
		Shock - MT64	MT64601006	
	Constant 800kg	Multi Leaf Spring	EL116R	3,4,5
		Shock - N/Sport	60109	2
		Shock - N/Plus	63109	
		Shock - MT64	MT64601008	
		Parabolic Spring	PB009R	3,4,9
		Shock - N/Plus	63401	2
	Shock - MT64	MT64601006		
	Constant 1000kg	Parabolic Spring	PB010R	3,4,9
		Shock - N/Plus	63401	2
		Shock - MT64	MT64601006	
	BP-51	Shock	BP5160028	2
		Shock Long	BP5160052	8
Fit Kit		VM80010007	1	
AIR BAG KIT		OMEAB003	1	10
SPRING BUSH KIT		OMESB86	2	1
		OMESB85		
GREASABLE SHACKLE KIT		OMEGS19	1	
GREASABLE FIXED END PIN KIT		OMEGP7		
U BOLT		OMEU59B	4	5
		OMEU59C		
		OMEU59D		
BRAKE PROPORTIONING VALVE		FK51	1	4
		FK58		

Comments

- 1** OMESB85: Use for all Models when installing OME greasable shackles & pins.
OMESB86: Use for Troop Carrier Models when original shackles & pins are used.
- 2** FK34 Sway Bar Extension Bracket Kit must be installed to prevent damage to sway bar mounts, due to increased suspension travel. FK34 not needed if fitting OMESTAB9.
- 3** OMESTAB9 Sway Bar is highly recommended fitment when 800kg Constant Spring is used. Sway Bar can also be fitted to lighter rated springs to improve road handling. FK76 suits Models with OE axle sway bar mount. FK77 suits Models without OE sway bar provision.
- 4** FK51 and FK58 Brake Proportioning Valve Kits (included in BP-51 Fit Kit) suit vehicles prior to August 2016 production. FK51 is for 200kg and 400kg Spring. FK58 is for 600kg and 800kg Spring.
- 5** Use OMEU59C if fitting Extra Leaf to EL116R. Use OMEU59D for parabolic leaf springs.
- 6** Required on Models 2014 TO 08/16.
- 7** Refer to **Leaf Spring Service Parts** section for Centre Bolt selection.
- 8** Suits EL116R **only**.
- 9** Air Bag Kit is a **mandatory** fitment.
- 10** Air Bag Kit is **not recommended** for Multi-Leaf Springs.
- 11** Not suitable for parabolic leaf springs.

FIT KITS & HARDWARE

Loc	Description	Part Number	Qty	Note
R	SWAY BAR	OMESTAB9	1	2,3
R	SWAY BAR FIT KIT	FK77		3
		FK76		3
R	SWAY BAR EXT BRACKET KIT	FK34	2	
R	EXTRA LEAF	EL14XL	2	11
R	EXTRA LEAF SPACER KIT	ELSK13		
R	CENTRE BOLT			7
R	TRIM PACKER	ELSK06	EA	
R	REAR BRAKE LINE DROP KIT	FK82	1	6

FRONT SELECTION

V8 DIESEL ENGINE		Part Number	Qty	Note	
Estimated Lift 40mm	No Bar	Spring	2859	1	2,3
		Shock - N/Sport	60008	2	
		Shock - N/Plus	63008		
	Bar Only	Spring	2853	1	2,3
		Shock - N/Sport	60008	2	
		Shock - N/Plus	63008		
	Bar/ Winch/ Accessories	Spring	2853	1	2,3
		Shock - N/Sport	60008	2	
		Shock - N/Plus	63008		
	MT64	Shock	MT64601003	2	
	BP-51	Shock	BP5160042	2	
		Fit Kit	VM80010006	1	

Comments

- 1 OMECA77B Caster Kit will increase caster angle by 2 degrees. Check manufacturer's specifications to determine if required.
- 2 For heavily loaded applications it may be necessary to step down one spring selection in the front to maintain correct rake.
- 3 For vehicles fitted with ABS brakes. FK65 fit kit is required for vehicles prior to August 2016 production. For vehicles post August 2016 production refer to PIB No 343 for instructions on adjustment.

FIT KITS & HARDWARE

Loc	Description	Part Number	Qty	Note
F	STEERING DAMPER	OMESD47		
F	CASTER KIT	OMECA77B	1	1
F	SWAY BAR SPACER KIT	FK19		4
F	TRIM PACKER	OME79PF10	EA	
F	UPGRADED FRONT SWAY BAR	OMESTAB3		
F	ABS WIRE BRACKET KIT	FK65	1	3
F	FRONT AXLE UPGRADE LABEL KIT	FAU701540		5

- 4 Should the front drive shaft contact the sway bar when the suspension is at full droop, use FK19 Spacer Kit to pack the sway bar down.

- 5 Full OME suspension system must be fitted.

FRONT SELECTION

6 CYL PETROL & DIESEL ENGINE		Part Number	Qty	Note	
Estimated Lift 40mm	No Bar	Spring	2856	1	2,3
		Shock - N/Sport	60008	2	
		Shock - N/Plus	63008		
	Bar Only	Spring	2859	1	2,3
		Shock - N/Sport	60008	2	
		Shock - N/Plus	63008		
	Bar/ Winch/ Accessories	Spring	2859	1	2,3
		Shock - N/Sport	60008	2	
		Shock - N/Plus	63008		
	MT64	Shock	MT64601003	2	
	BP-51	Shock	BP5160042	2	
		Fit Kit	VM80010006	1	

FIT KITS & HARDWARE

Loc	Description	Part Number	Qty	Note
F	STEERING DAMPER	OMESD24		
F	CASTER KIT	OMECA77B	1	1
F	SWAY BAR SPACER KIT	FK19		4
F	TRIM PACKER	OME79PF10	EA	
F	ABS WIRE BRACKET KIT	FK65	1	3
F	FRONT AXLE UPGRADE LABEL KIT	FAU701540		5

REAR SELECTION

ALL MODELS		Part Number	Qty	Note	
Estimated Lift 45mm	Constant 200kg	Multi Leaf Spring	EL113R	2	1,5,8
		Shock - N/Sport	60010		
		Shock - N/Plus	63010		
		Shock - MT64	MT64601005		
	Constant 400kg	Multi Leaf Spring	EL114R	2	1,5,8
		Parabolic Spring	PB007R		1,5,6,9
		Shock - N/Sport	60011		
		Shock - N/Plus	63011		
		Shock - MT64	MT64601006		
	Constant 600kg	Multi Leaf Spring	EL115R	2	1,5,8
		Parabolic Spring	PB008R		1,5,6,9
		Shock - N/Sport	60011		
		Shock - N/Plus	63011		
	Constant 800kg	Multi Leaf Spring	EL116R	2	1,2,4,5,8
		Shock - N/Sport	60109		
		Shock - N/Plus	63109		
		Shock - MT64	MT64601008		
		Parabolic Spring	PB009R	2	1,5,6,9
		Shock - N/Plus	63401		
	Constant 1000kg	Parabolic Spring	PB010R	2	1,5,6,9
Shock - N/Plus		63401			
BP-51	Shock	BP5160028	2		
	Shock Long	BP5160052		10	
	Fit Kit	VM80010007	1		
AIR BAG KIT		OMEAB003		8	
SPRING BUSH KIT		OMESB101			
		OMESB84	2	3	
		OMESB85			
GREASABLE SHACKLE KIT		OMEGB10			
GREASABLE FIXED END PIN KIT		OMEGP7	1		
U BOLT		OMEU59B			
		OMEU59C	4	2	
		OMEU59D			
BRAKE PROPORTIONING VALVE		FK51		5	
		FK58	1		
REAR BRAKE LINE DROP KIT		FK82		7	

Comments

- 1 Include tray weight in constant load calculation.
- 2 Use OMEU59C if fitting Extra Leaf to EL116R.
Use OMEU59D for parabolic leaf springs
- 3 OMESB101: Use on original shackles & pins for 79 Series Models from 07/2009 On. OMESB84: Use on original shackles & pins for 79 Series Models To 06/2009. OMESB85: Use for all Models when installing OME greasable shackles & pins.
- 4 OMESTAB9 Sway Bar is highly recommended fitment when 800kg Constant Spring is used. Sway Bar can also be fitted to lighter rated springs to improve road handling. FK76 suits Models with OE axle sway bar mount. FK77 suits Models without OE sway bar provision.
- 5 For vehicles fitted with ABS brakes an ABS Wire Bracket Kit must be fitted. FK51 and FK58 are included in BP-51 Fit Kit. FK51 is for 200kg and 400kg Spring. FK58 is for 600kg and 800kg Spring. Due to Variance in tray clearance on 79 Series please check vehicle before selecting Fit Kit.
- 6 When fitting parabolic springs to a vehicle with a rear sway bar, the mount plate may contact the sway bar & will need to be spaced down with 2 x ELSK06 & 1 x UCB17
- 7 FK82 Rear Brake Line Drop Kit is required to be fitted to vehicles from 10/14 to 08/16.
- 8 Air Bag Kit is **not recommended** for Multi-Leaf Springs.
- 9 Air Bag Kit is a **mandatory** fitment.
- 10 Suits EL116R **Only**.
- 11 Does not suit parabolic leaf springs.
- 12 Refer to **Leaf Spring Service Parts** section for Centre Bolt selection.

FIT KITS & HARDWARE

Loc	Description	Part Number	Qty	Note
R	SWAY BAR	OMESTAB9		
R	SWAY BAR FIT KIT	FK77	1	4
		FK76		
R	EXTRA LEAF	EL14XL	2	11
R	EXTRA LEAF SPACER KIT	ELSK13		
R	CENTRE BOLT		EA	12
R	TRIM PACKER	ELSK06		

FRONT SELECTION

DIESEL ENGINE		Part Number	Qty	Note
Estimated Lift 50mm	No Bar	Leaf Spring	CS006F	1,2
		Shock - N/Sport	60009	6
		Shock - N/Plus	63009	
	Bar Only	Leaf Spring	CS007F	2
		Shock - N/Sport	60063	
		Shock - N/Plus	63063	
	Bar/ Winch/ Accessories	Leaf Spring	CS007F	2
		Shock - N/Sport	60063	
		Shock - N/Plus	63063	

Comments

1 Vehicles with no front accessory weight will require the removal of the 4th leaf from the top of the spring stack. This is to maintain good shackle angle by not allowing the bump stop measurement to exceed 100mm.

2 Shackles: FK08 Anti Inversion Kit is **mandatory** fitment front and rear if greasable shackles are not fitted. Note: Spring Caster Wedge OMECW2 (2 degrees Caster Wedges) may be required to restore positive caster angle. Front end alignment check will indicate required adjustment.

3 There can be 2 spigot sizes in the rear fixed end pins on 75 Series LandCruisers. Check for correct size before ordering greasable pins. Part numbers are:
50mm spigot = OMEGP2.
51mm spigot = OMEGP4.

4 Include tray weight in constant load calculation.

5 D16XL is suitable for CS006F.

6 Refer to **Leaf Spring Service Parts** section for Centre Bolt selection.

FRONT SELECTION

PETROL ENGINE		Part Number	Qty	Note
Estimated Lift 50mm	No Bar	Leaf Spring	CS006F	1,2
		Shock - N/Sport	60009	6
		Shock - N/Plus	63009	
	Bar Only	Leaf Spring	CS006F	2
		Shock - N/Sport	60063	
		Shock - N/Plus	63063	
	Bar/ Winch/ Accessories	Leaf Spring	CS006F	2
		Shock - N/Sport	60063	
		Shock - N/Plus	63063	

FIT KITS & HARDWARE

Loc	Description	Part Number	Qty	Note
F	U BOLT	OMEU51	4	
F	SPRING BUSH KIT	OMESB1	2	
F	GREASABLE SHACKLE KIT	OMEGS2	1	
F	SHACKLE FIXED END PIN KIT	OMEGP1		
F	STEERING DAMPER	OMESD24		
F	ANTI INVERSION KIT	FK08	2	
F	EXTRA LEAF	D16XL	2	5
F	CENTRE BOLT			6

REAR SELECTION

ALL MODELS		Part Number	Qty	Note	
Estimated Lift 50mm	Medium Load	Leaf Spring	CS006R	2	2,4
		Shock - N/Sport	60010		
		Shock - N/Plus	63010		
	Constant 400kg	Leaf Spring	CS007R	2	2,4
		Shock - N/Sport	60011		
		Shock - N/Plus	63011		
	Constant 600kg	Leaf Spring	CS008R	2	2,4
		Shock - N/Sport	60011		
		Shock - N/Plus	63011		
	SPRING BUSH KIT		OMESB16	2	
	U BOLT		OMEU59B	4	
	GREASABLE SHACKLE KIT		OMEGS1		
SHACKLE FIXED END PIN KIT		OMEGP2	1	3	
		OMEGP4			

FIT KITS & HARDWARE

Loc	Description	Part Number	Qty	Note
R	ANTI INVERSION KIT	FK08	1	2
R	EXTRA LEAF	D25XL	2	6
R	CENTRE BOLT			

Comments

1 Vehicles with no front accessory weight will require the removal of the 4th leaf from the top of the spring stack. This is to maintain good shackle angle by not allowing the bump stop measurement to exceed 100mm.

2 Shackles: FK08 Anti Inversion Kit is **mandatory** fitment front and rear if greasable shackles are not fitted. Note: Spring Caster Wedge OMECW2 (2 degrees Caster Wedges) may be required to restore positive caster angle. Front end alignment check will indicate required adjustment.

3 There can be 2 spigot sizes in the rear fixed end pins on 75 Series LandCruisers. Check for correct size before ordering greasable pins. Part numbers are:
50mm spigot = OMEGP2.
51mm spigot = OMEGP4.

4 Include tray weight in constant load calculation.

5 D16XL is suitable for CS006F.

6 Refer to **Leaf Spring Service Parts** section for Centre Bolt selection.

FRONT SELECTION

4.2 DIESEL ENGINE		Part Number	Qty	Note
Estimated Lift 50mm	No Bar	Spring	2856	1
		Shock - N/Sport	60008	2
		Shock - N/Plus	63008	
	Bar Only	Spring	2859	1
		Shock - N/Sport	60008	2
		Shock - N/Plus	63008	
	Bar/ Winch/ Accessories	Spring	2859	1
		Shock - N/Sport	60008	2
		Shock - N/Plus	63008	

Comments

- 1** OMECA77B Caster Kit will increase caster angle by 3 degrees. Check manufacturer's specifications to determine if required.
- 2** If rear bump stop measurements exceed 150mm remove 3rd leaf.
- 3** OME greasable shackles OMEGS10 & greasable shackle fixed end pin kit OMEGP7 are **mandatory** fitment. OE shackles cannot be used.
- 4** D2XL extra leaf and UCB2 centre bolt is suitable for CS004RB spring.
- 5** Refer to **Leaf Spring Service Parts** section for Centre Bolt selection.

FIT KITS & HARDWARE

Loc	Description	Part Number	Qty	Note
F	STEERING DAMPER	OMESD24	1	
F	CASTER KIT	OMECA77B		1

REAR SELECTION

ALL MODELS		Part Number	Qty	Note	
Estimated Lift 60mm	Medium Load	Leaf Spring	CS017RB	2,3	
		Shock - N/Sport	60044	2	
		Shock - N/Plus	63044		
	Constant 250kg	Leaf Spring	CS004RB	2	2,3,4
		Shock - N/Sport	60044	2	
		Shock - N/Plus	63044		
	SPRING BUSH KIT		OMESB93	2	
	U BOLT		OMEU59A	4	
	GREASABLE SHACKLE KIT		OMEGS10	1	3
SHACKLE FIXED END PIN KIT		OMEGP7			

FIT KITS & HARDWARE

Loc	Description	Part Number	Qty	Note
R	EXTRA LEAF	D2XL	2	4
R	CENTRE BOLT			4,5

FRONT SELECTION

ALL MODELS		Part Number	Qty	Note
Estimated Lift 30mm	No Bar	Spring	2872	1
		Shock - N/Sport	60089	2
		Shock - N/Plus	63089	
	Bar Only	Spring	2874	1
		Shock - N/Sport	60089	2
		Shock - N/Plus	63089	
	Bar/ Winch/ Accessories	Spring	2874	1
		Shock - N/Sport	60089	2
		Shock - N/Plus	63089	

REAR SELECTION

ALL MODELS		Part Number	Qty	Note
Est Lift 40mm	Medium Load	Spring	2873	1
		Shock - N/Sport	60090	2
		Shock - N/Plus	63090	
	Constant 100kg	Spring	2875	1
		Shock - N/Sport	60090	2
		Shock - N/Plus	63090	

FRONT SELECTION - Estimated Lift 40mm

ALL MODELS		Part Number	Qty	Note
No Bar	Spring	2870	1	
	Shock - N/Sport	60094	2	
Bar Only	Spring	2876	1	
	Shock - N/Sport	60094	2	
Bar/ Winch/ Accessories	Spring	2876	1	
	Shock - N/Sport	60094	2	

Comments

- 1** 60095 fits left hand side.
- 60096 fits right hand side.

REAR SELECTION - Estimated Lift 50mm

ALL MODELS		Part Number	Qty	Note
Medium Load	Spring	2871	1	
	Shock - N/Sport	60095	2	1
	Shock - N/Sport	60096		

FRONT SELECTION

PETROL & DIESEL ENGINES		Part Number	Qty	Note	
Estimated Lift 50mm	No Bar	Leaf Spring	CS006F	2	1,3
		Shock - N/Sport	60009		
		Shock - N/Plus	63009		
	Bar Only	Leaf Spring	CS006F	2	1,3
		Shock - N/Sport	60009		
		Shock - N/Plus	63009		
	Bar/ Winch/ Accessories	Leaf Spring	CS006F	2	1,3
		Shock - N/Sport	60009		
		Shock - N/Plus	63009		
	SPRING BUSH KIT		OMESB1	2	
	U BOLT		OMEU51	4	
	GREASABLE SHACKLE KIT		OMEGS2	1	
SHACKLE FIXED END PIN KIT		OMEGP1			

FIT KITS & HARDWARE

Loc	Description	Part Number	Qty	Note
F	STEERING DAMPER	OMESD24	1	3
F	ANTI INVERSION KIT	FK08		

REAR SELECTION

ALL MODELS		Part Number	Qty	Note	
Estimated Lift 50mm	Medium Load	Leaf Spring	CS017RA/B	1+1	3
		Shock - N/Sport	60062	2	
		Shock - N/Plus	63062		
	Constant 200kg	Leaf Spring	CS004RA/B	1+1	2,3,5
		Shock - N/Sport	60062	2	
		Shock - N/Plus	63062		
	SPRING BUSH KIT		OMESB1	2	
	U BOLT		OMEU59A	4	
	GREASABLE SHACKLE KIT		OMEGS2	1	4
	SHACKLE FIXED END PIN KIT		OMEGP2		
			OMEGP4		

FIT KITS & HARDWARE

Loc	Description	Part Number	Qty	Note
R	ANTI INVERSION KIT	FK08	1	3
R	EXTRA LEAF	D2XL	2	5
R	CENTRE BOLT			5,6

Comments

1 Vehicles with no front accessory weight will require the removal of the 4th leaf from the top of the spring stack. This is to maintain good shackle angle by not allowing the bump stop measurement to exceed 100mm.

2 If bump stop measurement exceeds 150 - 160mm remove 3rd leaf from top of spring stack to prevent shock absorber from topping out.

3 Shackles: FK08 Anti Inversion Kit is **mandatory** fitment front and rear if greasable shackles are not fitted. Note: Spring Caster Wedge OMECW2 (2 degrees Caster Wedges) may be required to restore positive caster angle. Front end alignment check will indicate required adjustment.

4 There can be 2 spigot sizes of the rear fixed end pins. Check spigot size before ordering greasable pins.

50mm spigot = OMEGP2

51mm spigot = OMEGP4

5 D2XL extra leaf and UCB2 centre bolt are suitable for CS004RA/B springs.

6 Refer to **Leaf Spring Service Parts** section for Centre Bolt selection.

FRONT SELECTION

DIESEL ENGINE		Part Number	Qty	Note
Estimated Lift 50mm	No Bar	Leaf Spring	CS004F	1,2,7
		Shock - N/Sport	60009	8
		Shock - N/Plus	63009	
	Bar Only	Leaf Spring	CS005F	1,2
		Shock - N/Sport	60063	8
		Shock - N/Plus	63063	
	Bar/ Winch/ Accessories	Leaf Spring	CS005F	1,2
		Shock - N/Sport	60063	8
		Shock - N/Plus	63063	

Comments

1 Front bump stop measurement **must** not exceed 100mm to ensure good shackle angle. To reduce bump stop gap, remove the 4th leaf from the top of the spring. OMECW2 Caster Wedge Kit may be required to restore correct caster angle.

2 Shackles: FK08 Anti Inversion Kit is **mandatory** fitment if greasable shackles are not fitted. Refer OME Technical & Fitting Manual.

3 Post 1986 vehicles have a 19mm mounting pin and suit shock part no's 60062 & 60065. Pre 1986 vehicles have a 16mm mounting pin and suit shock part no's 60032 & 60064.

4 Fitting Kit is only required on vehicles with rubber insulators around rear springs. Refer OME Technical & Fitting Manual Section 7 GFI: LandCruiser 60 Series page 7 selection chart.

5 Barn door Models may require A/A or B/B spring fitment.

6 D1XL only suitable for CS003F & CS004F. D2XL only suitable for CS004RA/B & CS005RA/B

7 Refer to **Leaf Spring Service Parts** section for Centre Bolt selection.

FRONT SELECTION

PETROL ENGINE		Part Number	Qty	Note
Estimated Lift 50mm	No Bar	Leaf Spring	CS003F	1,2,7
		Shock - N/Sport	60009	8
		Shock - N/Plus	63009	
	Bar Only	Leaf Spring	CS004F	1,2,7
		Shock - N/Sport	60063	8
		Shock - N/Plus	63063	
	Bar/ Winch/ Accessories	Leaf Spring	CS004F	1,2,7
		Shock - N/Sport	60063	8
		Shock - N/Plus	63063	

FIT KITS & HARDWARE

Loc	Description	Part Number	Qty	Note
F	SPRING BUSH KIT	OMESB1	2	
F	U BOLT	OMEU51	4	
F	GREASABLE SHACKLE KIT	OMEGS2	1	
F	SHACKLE FIXED END PIN KIT	OMEGP1		
F	STEERING DAMPER	OMESD24		
F	ANTI INVERSION KIT	FK08		2
F	EXTRA LEAF	D1XL	2	6
F	CENTRE BOLT			7

REAR SELECTION

ALL MODELS		Part Number	Qty	Note	
Estimated Lift 50mm	Light Load	Leaf Spring	CS017RA/B	1+1	2,5
		Shock - N/Sport	60032	2	3
		Shock - N/Sport	60062		
		Shock - N/Plus	63032		
		Shock - N/Plus	63062		
	Medium Load	Leaf Spring	CS004RA/B	1+1	2,5,6
		Shock - N/Sport	*60064 / 60032	2	3
		Shock - N/Sport	*60065 / 60062		
		Shock - N/Plus	*63064 / 63032		
		Shock - N/Plus	*63065 / 63062		
		Fitting Kit	FK0422	1	4
	Fitting Kit	FK0411			
	Constant 200kg	Leaf Spring	CS005RA/B	1+1	2,5,6
		Shock - N/Sport	60064	2	3
		Shock - N/Sport	60065		
		Shock - N/Plus	63064		
		Shock - N/Plus	63065		
		Fitting Kit	FK0418	1	4
SPRING BUSH KIT		OMESB1	2		
U BOLT		OMEU59B	4		
GREASABLE SHACKLE KIT		OMEGS1	1		
SHACKLE FIXED END PIN KIT		OMEGP1			

Comments

1 Front bump stop measurement **must** not exceed 100mm to ensure good shackle angle. To reduce bump stop gap, remove the 4th leaf from the top of the spring. OMECW2 Caster Wedge Kit may be required to restore correct caster angle.

2 Shackles: FK08 Anti Inversion Kit is **mandatory** fitment if greasable shackles are not fitted. Refer OME Technical & Fitting Manual.

3 Post 1986 vehicles have a 19mm mounting pin and suit shock part no's 60062 & 60065. Pre 1986 vehicles have a 16mm mounting pin and suit shock part no's 60032 & 60064.

4 Fitting Kit is only required on vehicles with rubber insulators around rear springs. Refer OME Technical & Fitting Manual Section 7 GFI: LandCruiser 60 Series page 7 selection chart.

5 Barn door Models may require A/A or B/B spring fitment.

6 D1XL only suitable for CS003F & CS004F. D2XL only suitable for CS004RA/B & CS005RA/B.

7 Refer to **Leaf Spring Service Parts** section for Centre Bolt selection.

FIT KITS & HARDWARE

Loc	Description	Part Number	Qty	Note
R	ANTI INVERSION KIT	FK08	1	2
R	EXTRA LEAF	D2XL	2	6
R	CENTRE BOLT			7

FRONT SELECTION

PETROL & DIESEL ENGINES		Part Number	Qty	Note
Estimated Lift 35mm	No Bar	Leaf Spring	CS001F	1,2
		Shock - N/Sport	60097	
		Shock - N/Plus	63097	
	Bar Only	Leaf Spring	CS002F	1,2
		Shock - N/Sport	60097	2
		Shock - N/Plus	63097	
	Bar/ Winch/ Accessories	Leaf Spring	CS002F	1,2
		Shock - N/Sport	60097	2
		Shock - N/Plus	63097	

Comments

- 1** FK08 Anti Inversion Kit is **mandatory** fitment front and rear if greasable shackles are not fitted.
- 2** Include tray weight in constant load calculation. Remove 3rd leaf from CS003R spring stack to reduce spring rate for light duty applications.
- 3** Refer to **Leaf Spring Service Parts** section for Centre Bolt selection.

FIT KITS & HARDWARE

Loc	Description	Part Number	Qty	Note
F	SPRING BUSH KIT	SEE CHART BELOW	2	
F	U BOLT - 25mm Eye Spring	OMEU59A	3	
		OMEU59B	1	
F	U BOLT - 35mm Eye Spring	OMEU59A	3	
		OMEU55	1	
F	GREASABLE SHACKLE KIT	SEE CHART BELOW		
F	STEERING DAMPER	OMESD23	1	
F	ANTI INVERSION KIT	FK08		1
F	EXTRA LEAF	D3XL	2	
F	CENTRE BOLT			3

GREASABLE SHACKLES & BUSH KITS

FRONT	KIT PART NO.	QTY	COMPATIBLE BUSH KIT	QTY
18mm Shackle Pins & 35mm Hanger Bracket	OMEGS2	1	OMESB1	2
	OMEGP1			
15mm Shackle Pins & 25mm Hanger Bracket	OMEGS8	1	OMESB30	2
	OMEGP8			

REAR SELECTION

ALL MODELS		Part Number	Qty	Note	
Est Lift 50mm	Medium Load	Leaf Spring	CS003R	1,2	
		Shock - N/Sport	60032	2	
		Shock - N/Plus	63032		
	Constant 400kg	Leaf Spring	CS003R	1,2	
		Shock - N/Sport	60064	2	
		Shock - N/Plus	63064		
	SPRING BUSH KIT		SEE CHART BELOW	2	
	U BOLT		OMEU59B	4	
	GREASABLE SHACKLE KIT		SEE CHART BELOW	1	

FIT KITS & HARDWARE

Loc	Description	Part Number	Qty	Note
F	TRIM PACKER	TP02	EA	
F	ANTI INVERSION KIT	FK08	1	
F	EXTRA LEAF	D8XL	2	1
F	CENTRE BOLT			3

GREASABLE SHACKLES & BUSH KITS

REAR	KIT PART NO.	QTY	COMPATIBLE BUSH KIT	QTY
18mm Shackle Pins & 30mm Hanger Bracket	OMEGS17	1	OMESB79	2
	*GSP02	2		
15mm Shackle Pins & 25mm Hanger Bracket	OMEGS9	1	OMESB30	2
	OMEGP8			

* GSP02 is only a greasable pin replacement for original pin.

FRONT SELECTION

PETROL & DIESEL ENGINES		Part Number	Qty	Note	
Estimated Lift 35mm	No Bar	Leaf Spring	CS001F	2	
		Shock - N/Sport	60097		
		Shock - N/Plus	63097		
	Bar Only	Leaf Spring	CS002F	2	2
		Shock - N/Sport	60097		
		Shock - N/Plus	63097		
	Bar/ Winch/ Accessories	Leaf Spring	CS002F	2	2
		Shock - N/Sport	60097		
		Shock - N/Plus	63097		
	SPRING BUSH KIT		OMESB30	2	1
			OMESB1		
	U BOLT - 25mm Eye Spring		OMEU59A	3	
		OMEU59B	1		
U BOLT - 35mm Eye Spring		OMEU59A	3		
		OMEU55	1		
GREASABLE SHACKLE KIT		SEE CHART BELOW	1		

Comments

- 1** OMESB30 suits 35mm spring eye and 25mm hanger bracket with 15mm shackle pin hole.
OMESB1 suits 35mm spring eye and hanger bracket with 18mm shackle pin hole.
- 2** FK08 Anti Inversion Kit is mandatory fitment front and rear if greasable shackles are not fitted.
- 3** 1975 and newer FJ 40's may need to use N76 shocks in the rear:

Pre 1975 shock eye in the top of the axle housing: Use 60032 / 60064

Post 1975 lower shock eye is below leaf spring: Use N76 with OMEB11 Bush Kit
- 4** Refer to **Leaf Spring Service Parts** section for Centre Bolt selection.

FIT KITS & HARDWARE

Loc	Description	Part Number	Qty	Note
F	STEERING DAMPER	OMESD23	1	
F	ANTI INVERSION KIT	FK08	2	2
F	EXTRA LEAF	D3XL	2	
F	CENTRE BOLT		4	4

GREASABLE SHACKLES & BUSH KITS

FRONT	KIT PART NO.	QTY	COMPATIBLE BUSH KIT	QTY
18mm Shackle Pin	OMEGS2	1	OMESB1	2
	OMEGP1			
15mm Shackle Pin	OMEGS8	1	OMESB30	2
	OMEGP8			

REAR SELECTION

ALL MODELS		Part Number	Qty	Note	
Estimated Lift 50mm	Medium Load	Leaf Spring	CS001R	3	
		Shock - N/Sport	60032	2	
		Shock - N/Plus	63032		
	Constant 150kg	Leaf Spring	CS002R	2	2,3
		Shock - N/Sport	*60064 / 60032		
		Shock - N/Plus	*63064 / 63032		
	U BOLT		OMEU59A	4	
	SPRING BUSH KIT		OMESB30	2	1
			OMESB1		
	GREASABLE SHACKLE KIT		SEE CHART BELOW	1	

Comments

- 1** OMESB30 suits 35mm spring eye and 25mm hanger bracket with 15mm shackle pin hole.
OMESB1 suits 35mm spring eye and hanger bracket with 18mm shackle pin hole.
- 2** FK08 Anti Inversion Kit is mandatory fitment front and rear if greasable shackles are not fitted.
- 3** 1975 and newer FJ 40's may need to use N76 shocks in the rear:
Pre 1975 shock eye in the top of the axle housing: Use 60032 / 60064
Post 1975 lower shock eye is below leaf spring: Use N76 with OMEB11 Bush Kit
- 4** Refer to **Leaf Spring Service Parts** section for Centre Bolt selection.

FIT KITS & HARDWARE

Loc	Description	Part Number	Qty	Note
R	ANTI INVERSION KIT	FK08	1	2
R	EXTRA LEAF	D4XL	2	4
R	CENTRE BOLT			

GREASABLE SHACKLES & BUSH KITS

REAR	KIT PART NO.	QTY	COMPATIBLE BUSH KIT	QTY
18mm Shackle Pin	OMEGS2	1	OMESB1	2
	OMEGP1			
15mm Shackle Pin	OMEGS9	1	OMESB30	2
	OMEGP8			

FRONT SELECTION

2.8L & 3.0L DIESEL ENGINE		Part Number	Qty	Note	
Estimated Lift 40mm	No Bar	Spring	2885	1	1,3,6
		Strut - N/Sport	90010	2	2
	Bar Only	Spring	2887	1	1,3,6
		Strut - N/Sport	90010	2	2
	Bar/ Winch/ Accessories	Spring	2888	1	1,3,6
		Strut - N/Sport	90010	2	2
	Nitro +	Spring	4002	1	1,3,6
		Strut	93010	2	2,7
	MT64	Spring	4002	1	1,3,6
		Strut	MT64901007	2	2,7
	BP-51 NO KDSS	Strut - LH	BP5190002L	1+1	
		Strut - RH	BP5190002R		
		Fit Kit	VM80010008	1	
	BP-51 SUITS KDSS	Strut - LH	BP5190004L	1+1	3
Strut - RH		BP5190002R			
Fit Kit		VM80010009	1		

Comments

- 1 Vehicles with KDSS, must have 1 x OME95PF5 packer installed on the front right hand side to maintain correct trim. For Plus & MT-64 use included packers/ snap rings.
- 2 No top mounting bushes supplied use OME3133. OE bushes may be re-used if on good condition.
- 3 For fitment to Models with Toyota's KDSS (Kinetic Dynamic Suspension System) fitted excluding Kakadu Models, please refer to OME's Fitting Hints & Tips (OME Bulletin 70 LC200 KDSS Fitting Hints).
- 4 Strut Top Hat Kit may be required if original equipment is worn.
- 5 The OME Upper Control Arm will provide an increase between +2.5 and +3.5 degrees of caster and up to 1.5 degrees of negative camber increase (figures based off an approximate 50mm lift). Please note after fitment of Upper Control Arm a vehicle wheel alignment will be required.
- 6 Front coils can go into Kakadu OE Strut, no option for rear. Use to correct front trimming/weight issues to regain height.
- 7 Does not suit OE coil.

FRONT SELECTION

2.8L & 3.0L DIESEL ENGINE		Part Number	Qty	Note	
Estimated Lift 20mm	No Bar	Spring	2869	1	1,3,6
		Strut - N/Sport	90010	2	2
	Bar Only	Spring	2884	1	1,3,6
		Strut - N/Sport	90010	2	2
	Bar/ Winch/ Accessories	Spring	2885	1	1,3,6
		Strut - N/Sport	90010	2	2
	Nitro +	Spring	4005	1	1,3,6
		Strut	93010	2	2,7
	MT64	Spring	4005	1	1,3,6
		Strut	MT64901007	2	2,7
	BP-51 NO KDSS	Strut - LH	BP5190002L	1+1	
		Strut - RH	BP5190002R		
		Fit Kit	VM80010008	1	
	BP-51 SUITS KDSS	Strut - LH	BP5190004L	1+1	
Strut - RH		BP5190002R			
Fit Kit		VM80010009	1		

FIT KITS & HARDWARE

Loc	Description	Part Number	Qty	Note
F	UPPER CONTROL ARM	UCA0004	1	5
F	TRIM PACKER	OME95PF5	EA	1
F	UPPER STRUT BUSHES	OME3133	2	2
F	STRUT TOP HAT KIT	OMETH002		4

SERVICE PARTS

Description	Part #	Qty	Note
OME UCA Eye Bush 2pk	UCASPO10	1	
OME UCA Ball Joint 1pk	UCASPO02	EA	
OME UCA Boot 2pk	UCASPO11	1	

FRONT SELECTION

V6 4.0L PETROL ENGINE		Part Number	Qty	Note	
Estimated Lift 40mm	No Bar	Spring	2884	1 1,3,6	
		Strut - N/Sport	90010	2 2	
	Bar Only	Spring	2885	1 1,3,6	
		Strut - N/Sport	90010	2 2	
	Bar/ Winch/ Accessories	Spring	2887	1 1,3,6	
		Strut - N/Sport	90010	2 2	
	Nitro +	Spring	4000	1 1,3,6	
		Strut - N/Plus	93010	2 2,7	
	MT64	Spring	4000	1 1,3,6	
		Strut	MT64901007	2 2,7	
	BP-51 NO KDSS	Strut - LH	BP5190002L	1+1	
		Strut - RH	BP5190002R		
		Fit Kit	VM80010008	1	
	BP-51 SUITS KDSS	Strut - LH	BP5190004L	1+1	
Strut - RH		BP5190002R			
Fit Kit		VM80010009	1		

Comments

- 1 Vehicles with KDSS, must have 1 x OME95PF5 packer installed on the front right hand side to maintain correct trim. For Plus & MT-64 use included packers/ snap rings.
- 2 No top mounting bushes supplied use OME3133. OE bushes may be re-used if on good condition.
- 3 For fitment to Models with Toyota's KDSS (Kinetic Dynamic Suspension System) fitted excluding Kakadu Models, please refer to OME's Fitting Hints & Tips (OME Bulletin 70 LC200 KDSS Fitting Hints).
- 4 Strut Top Hat Kit may be required if original equipment is worn.
- 5 The OME Upper Control Arm will provide an increase between +2.5 and +3.5 degrees of caster and up to 1.5 degrees of negative camber increase (figures based off an approximate 50mm lift). Please note after fitment of Upper Control Arm a vehicle wheel alignment will be required.
- 6 Front coils can go into Kakadu OE Strut, no option for rear. Use to correct front trimming/weight issues to regain height.
- 7 Does not suit OE coil.

FRONT SELECTION

V6 4.0L PETROL ENGINE		Part Number	Qty	Note	
Estimated Lift 20mm	No Bar	Spring	2883	1 1,3,6	
		Strut - N/Sport	90010	2 2	
	Bar Only	Spring	2869	1 1,3,6	
		Strut - N/Sport	90010	2 2	
	Bar/ Winch/ Accessories	Spring	2884	1 1,3,6	
		Strut - N/Sport	90010	2 2	
	Nitro +	Spring	4001	1 1,3,6	
		Strut - N/Plus	93010	2 2,7	
	MT64	Spring	4001	1 1,3,6	
		Strut	MT64901007	2 2,7	
	BP-51 NO KDSS	Strut - LH	BP5190002L	1+1	
		Strut - RH	BP5190002R		
		Fit Kit	VM80010008	1	
	BP-51 SUITS KDSS	Strut - LH	BP5190004L	1+1	
Strut - RH		BP5190002R			
Fit Kit		VM80010009	1		

FIT KITS & HARDWARE

Loc	Description	Part Number	Qty	Note
F	UPPER CONTROL ARM	UCA0004	1	5
F	TRIM PACKER	OME95PF5	EA	1
F	UPPER STRUT BUSHES	OME3133	2	2
F	STRUT TOP HAT KIT	OMETH002		4

SERVICE PARTS

Description	Part #	Qty	Note
OME UCA Eye Bush 2pk	UCASP010	1	
OME UCA Ball Joint 1pk	UCASP002	EA	
OME UCA Boot 2pk	UCASP011	1	

REAR SELECTION

WAGON MODELS		Part Number	Qty	Note	
Estimated Lift 40mm	Medium Load	Spring	2889	1	2
		Shock - N/Sport	60080		1
		Shock - N/Plus	63080	2	
		Shock - MT64	MT64601009		
	Constant 200kg	Spring	2898	1	2
		Shock - N/Sport	*60081 / 60080		1
		Shock - N/Plus	*63081 / 63080	2	
		Shock - MT64	MT64601009		
	Constant 400kg	Shock - MT64	*MT64601010		
		Spring	2899	1	2
		Shock - N/Sport	60081		1
		Shock - N/Plus	63081	2	
	BP-51	Shock - MT64	MT64601010		
		Shock	BP5160025	2	
		Fit Kit	VM80010010	1	

Comments

1 OME661 Lower Shock Mount Stone Guard is recommended fitment to rear shocks to protect against severe stone peppering encountered on loose road surfaces.

2 For fitment to Models with Toyota's KDSS (Kinetic Dynamic Suspension System) fitted excluding Kakadu Models, please refer to OME's Fitting Hints & Tips (OME Bulletin 70 LC200 KDSS Fitting Hints).

REAR SELECTION

WAGON MODELS		Part Number	Qty	Note	
Estimated Lift 20mm	Medium Load	Spring	2895E	1	2
		Shock - N/Sport	60080		1
		Shock - N/Plus	63080	2	
		Shock - MT64	MT64601009		
	Constant 200kg	Spring	2895	1	2
		Shock - N/Sport	*60081 / 60080		1
		Shock - N/Plus	*63081 / 63080	2	
		Shock - MT64	MT64601009		
	Constant 400kg	Shock - MT64	*MT64601010		
		Spring	2896	1	2
		Shock - N/Sport	60081		1
		Shock - N/Plus	63081	2	
	BP-51	Shock - MT64	MT64601010		
		Shock	BP5160025	2	
		Fit Kit	VM80010010	1	

FIT KITS & HARDWARE

Loc	Description	Part Number	Qty	Note
R	TRIM PACKER	OME150PR10	EA	
R	STONE GUARD KIT	OME661	1	1

FRONT SELECTION

2.8L & 3.0L DIESEL ENGINE		Part Number	Qty	Note	
Estimated Lift 50mm	No Bar	Spring	2884	1	1,3
		Strut - N/Sport	90010	2	2,6
	Bar Only	Spring	2885	1	1,3
		Strut - N/Sport	90010	2	2,6
	Bar/ Winch/ Accessories	Spring	2887	1	1,3
		Strut - N/Sport	90010	2	2,6
	Nitro +	Spring	4000	1	1,3,6
		Strut	93010	2	2,7
	MT64	Spring	4000	1	1,3,6
		Strut	MT64901007	2	2,7
	BP-51 NO KDSS	Strut - LH	BP5190002L	1+1	
		Strut - RH	BP5190002R		
		Fit Kit	VM80010008	1	
	BP-51 SUITS KDSS	Strut - LH	BP5190004L	1+1	
Strut - RH		BP5190002R			
Fit Kit		VM80010009	1		

Comments

- 1 Vehicles with KDSS, must have 1 x OME95PF5 packer installed on the front right hand side to maintain correct trim. For Plus & MT-64 use included packers/ snap rings.
- 2 No top mounting bushes supplied use OME3133. OE bushes may be re-used if on good condition.
- 3 For fitment to Models with Toyota's KDSS (Kinetic Dynamic Suspension System) fitted excluding Kakadu Models, please refer to OME's Fitting Hints & Tips (OME Bulletin 70 LC200 KDSS Fitting Hints).
- 4 When 2883 is fitted to Petrol Model, ride height increase will be approximately 40mm.
- 5 The OME Upper Control Arm will provide an increase between +2.5 and +3.5 degrees of caster and up to 1.5 degrees of negative camber increase (figures based off an approximate 50mm lift). Please note after fitment of Upper Control Arm a vehicle wheel alignment will be required.
- 6 Strut Top Hat Kit may be required if original equipment is worn.
- 7 Does not suit OE coil.

FRONT SELECTION

2.8L & 3.0L DIESEL ENGINE		Part Number	Qty	Note	
Estimated Lift 30mm	No Bar	Spring	2883	1	1,3
		Strut - N/Sport	90010	2	2,6
	Bar Only	Spring	2869	1	1,3
		Strut - N/Sport	90010	2	2,6
	Bar/ Winch/ Accessories	Spring	2884	1	1,3
		Strut - N/Sport	90010	2	2,6
	Nitro +	Spring	4001	1	1,3
		Strut	93010	2	2,7
	MT64	Spring	4000	1	3,6
		Strut	MT64901007	2	2,7
	BP-51 NO KDSS	Strut - LH	BP5190002L	1+1	
		Strut - RH	BP5190002R		
		Fit Kit	VM80010008	1	
	BP-51 SUITS KDSS	Strut - LH	BP5190004L	1+1	
Strut - RH		BP5190002R			
Fit Kit		VM80010009	1		

FIT KITS & HARDWARE

Loc	Description	Part Number	Qty	Note
F	UPPER CONTROL ARM	UCA0004	1	5
F	TRIM PACKER	OME95PF5	EA	1
F	UPPER STRUT BUSHES	OME3133	2	2
F	STRUT TOP HAT KIT	OMETH002		6

SERVICE PARTS

Description	Part #	Qty	Note
OME UCA Eye Bush 2pk	UCASP010	1	
OME UCA Ball Joint 1pk	UCASP002	EA	
OME UCA Boot 2pk	UCASP011	1	

FRONT SELECTION

V6 4.0L PETROL ENGINE		Part Number	Qty	Note	
Estimated Lift 50mm	No Bar	Spring	2869	1	1,3
		Strut - N/Sport	90010	2	2,6
	Bar Only	Spring	2884	1	1,3
		Strut - N/Sport	90010	2	2,6
	Bar/ Winch/ Accessories	Spring	2885	1	1,3
		Strut - N/Sport	90010	2	2,6
	Nitro +	Spring	4005	1	1,3
		Strut - N/Plus	93010	2	2,6,7
	MT64	Spring	4005	1	1,3
		Strut	MT64901007	2	2,6,7
	BP-51 NO KDSS	Strut - LH	BP5190002L	1+1	
		Strut - RH	BP5190002R		
Fit Kit		VM80010008	1		
BP-51 SUITS KDSS	Strut - LH	BP5190004L	1+1		
	Strut - RH	BP5190002R			
	Fit Kit	VM80010009	1		

Comments

- 1 Vehicles with KDSS, must have 1 x OME95PF5 packer installed on the front right hand side to maintain correct trim. For Plus & MT-64 use included packers/ snap rings.
- 2 No top mounting bushes supplied use OME3133. OE bushes may be re-used if on good condition.
- 3 For fitment to Models with Toyota's KDSS (Kinetic Dynamic Suspension System) fitted excluding Kakadu Models, please refer to OME's Fitting Hints & Tips (OME Bulletin 70 LC200 KDSS Fitting Hints).
- 4 When 2883 is fitted to Petrol Model, ride height increase will be approximately 40mm.
- 5 The OME Upper Control Arm will provide an increase between +2.5 and +3.5 degrees of caster and up to 1.5 degrees of negative camber increase (figures based off an approximate 50mm lift). Please note after fitment of Upper Control Arm a vehicle wheel alignment will be required.
- 6 Strut Top Hat Kit may be required if original equipment is worn.
- 7 Does not suit OE coil.

FRONT SELECTION

V6 4.0L PETROL ENGINE		Part Number	Qty	Note	
Estimated Lift 30mm	No Bar	Spring	2883	1	1,3,4
		Strut - N/Sport	90010	2	2,6
	Bar Only	Spring	2883	1	1,3,4
		Strut - N/Sport	90010	2	2,6
	Bar/ Winch/ Accessories	Spring	2869	1	1,3
		Strut - N/Sport	90010	2	2,6
	Nitro +	Spring	4001	1	1,3
		Strut - N/Plus	93010	2	2,6,7
	MT64	Spring	4001	1	1,3
		Strut	MT64901007	2	2,6,7
	BP-51 NO KDSS	Strut - LH	BP5190002L	1+1	
		Strut - RH	BP5190002R		
Fit Kit		VM80010008	1		
BP-51 SUITS KDSS	Strut - LH	BP5190004L	1+1		
	Strut - RH	BP5190002R			
	Fit Kit	VM80010009	1		

FIT KITS & HARDWARE

Loc	Description	Part Number	Qty	Note
F	UPPER CONTROL ARM	UCA0004	1	5
F	TRIM PACKER	OME95PF5	EA	1
F	UPPER STRUT BUSHES	OME3133	2	2
F	STRUT TOP HAT KIT	OMETH002		6

SERVICE PARTS

Description	Part #	Qty	Note
OME UCA Eye Bush 2pk	UCASP010	1	
OME UCA Ball Joint 1pk	UCASP002	EA	
OME UCA Boot 2pk	UCASP011	1	

REAR SELECTION

WAGON MODELS		Part Number	Qty	Note	
Estimated Lift 50mm	Medium Load	Spring	2889	1	2
		Shock - N/Sport	60080	2	1
		Shock - N/Plus	63080		
		Shock - MT64	MT64601009		
	Constant 200kg	Spring	2898	1	2
		Shock - N/Sport	*60081 / 60080	2	1
		Shock - N/Plus	*63081 / 63080		
		Shock - MT64	MT64601009		
		Shock - MT64	*MT64601010		
	Constant 400kg	Spring	2899	1	2
		Shock - N/Sport	60081	2	1
		Shock - N/Plus	63081		
		Shock - MT64	MT64601010		
	BP-51	Shock	BP5160025	2	
		Fit Kit	VM80010010	1	

Comments

- 1** OME661 Lower Shock Mount Stone Guard is recommended fitment to rear shocks to protect against severe stone peppering encountered on loose road surfaces.
- 2** For fitment to Models with Toyota's KDSS (Kinetic Dynamic Suspension System) fitted excluding Kakadu Models, please refer to OME's Fitting Hints & Tips (OME Bulletin 70 LC200 KDSS Fitting Hints).

REAR SELECTION

WAGON MODELS		Part Number	Qty	Note	
Estimated Lift 20mm	Medium Load	Spring	2895E	1	2
		Shock - N/Sport	60080	2	1
		Shock - N/Plus	63080		
		Shock - MT64	MT64601009		
	Constant 200kg	Spring	2895	1	2
		Shock - N/Sport	*60081 / 60080	2	1
		Shock - N/Plus	*63081 / 63080		
		Shock - MT64	MT64601009		
		Shock - MT64	*MT64601010		
	Constant 400kg	Spring	2896	1	2
		Shock - N/Sport	60081	2	1
		Shock - N/Plus	63081		
		Shock - MT64	MT64601010		
	BP-51	Shock	BP5160025	2	
		Fit Kit	VM80010010	1	

FIT KITS & HARDWARE

Loc	Description	Part Number	Qty	Note
R	TRIM PACKER	OME150PR10	EA	
R	STONE GUARD KIT	OME661	1	1

FRONT SELECTION

3.0L DIESEL ENGINE		Part Number	Qty	Note	
Estimated Lift 40mm	No Bar	Spring	2869	1	1
		Strut - N/Sport	90016	2	2
	Bar Only	Spring	2884	1	1
		Strut - N/Sport	*90010 / 90016	2	2
	Bar/ Winch/ Accessories	Spring	2885	1	1
		Strut - N/Sport	90010	2	2
	Nitro +	Spring	4005	1	1
		Strut	93010	2	2,5
	MT64	Spring	4005	1	1
		Strut	MT64901007	2	2,5

Comments

- 1 No top mounting bushes supplied use OME3133. OE bushes may be re-used if in good condition.
- 2 OME661 Lower Shock Mount Stone Guard is recommended fitment to rear shocks to protect against severe stone peppering encountered on loose road surfaces.
- 3 Strut Top Hat Kit may be required if original equipment is worn.
- 4 Vehicles with KDSS, must have 1 x OME95PF5 packer installed on the front right hand side to maintain correct trim.
- 5 Does not suit OE coil.
- 6 Heavy Tune is suitable for 200kg springs & Mandatory for 400kg springs

FRONT SELECTION

V6 4.0L PETROL ENGINE		Part Number	Qty	Note	
Estimated Lift 40mm	No Bar	Spring	2883	1	1
		Strut - N/Sport	90016	2	2
	Bar Only	Spring	2869	1	1
		Strut - N/Sport	*90010 / 90016	2	2
	Bar/ Winch/ Accessories	Spring	2884	1	1
		Strut - N/Sport	90010	2	2
	Nitro +	Spring	4001	1	1
		Strut	93010	2	2,5
	MT64	Spring	4001	1	1
		Strut	MT64901007	2	2,5

FIT KITS & HARDWARE

Loc	Description	Part Number	Qty	Note
F	TRIM PACKER	OME95PF5	EA	4
F	UPPER STRUT BUSHES	OME3133	2	1
F	STRUT TOP HAT KIT	OMETH002		3

REAR SELECTION

WAGON MODELS		Part Number	Qty	Note	
Estimated Lift 40mm	Medium Load	Spring	2895E	1	
		Shock - N/Sport	60086		2
		Shock - N/Plus	63086	2	
		Shock - MT64	MT64601011		
	Constant 200kg	Spring	2895	1	
		Shock - N/Sport	*60080 / 60086		2
		Shock - N/Plus	*63080 / 63086	2	
		Shock - MT64	MT64601011		
	Constant 400kg	Spring	2896	1	
		Shock - N/Sport	60080		2
		Shock - N/Plus	63080	2	
		Shock - MT64	MT64601009		

FIT KITS & HARDWARE

Loc	Description	Part Number	Qty	Note
R	TRIM PACKER	OME150PR10	EA	
R	STONE GUARD KIT	OME661	1	2

FRONT SELECTION

PETROL & DIESEL ENGINES		Part Number	Qty	Note	
Estimated Lift 25mm	No Bar	Spring	2883	1	1
		Strut - N/Sport	*90000 / 90021	2	2
	Bar Only	Spring	2884	1	1
		Strut - N/Sport	90000	2	2
	Bar/ Winch/ Accessories	Spring	2885	1	1
		Strut - N/Sport	90000	2	2
	Nitro +	Spring	4007	1	1
		Strut - N/Plus	93000	2	2,6
	BP-51	Strut LH	BP5190002L	1+1	
		Strut RH	BP5190002R		
Fit Kit		VM80010029	1		

FIT KITS & HARDWARE

Loc	Description	Part Number	Qty	Note
F	UPPER CONTROL ARMS	UCA0004	1	4
F	TRIM PACKER	OME95PF5	EA	
F	UPPER STRUT BUSHES	OME3133	2	2
F	STRUT TOP HAT KIT	OMETH002		3

SERVICE PARTS

Description	Part #	Qty	Note
OME UCA Eye Bush 2pk	UCASP010	1	
OME UCA Ball Joint 1pk	UCASP002	EA	
OME UCA Boot 2pk	UCASP011	1	

Comments

- 1** To maintain front strut droop it is important front coils are selected as shown.
- 2** No top mounting bushes supplied use OME3133. OE bushes may be re-used if in good condition.
- 3** Strut Top Hat Kit may be required if original equipment is worn.
- 4** The OME Upper Control Arm will provide an increase between +2.5 and +3.5 degrees of caster and up to 1.5 degrees of negative camber increase (figures based off an approximate 50mm lift). Please note after fitment of Upper Control Arm a vehicle wheel alignment will be required.
- 5** OME661 Lower Shock Mount Stone Guard is recommended fitment to rear shocks to protect against severe stone peppering encountered on loose road surfaces.
- 6** Does not suit OE coil.

REAR SELECTION

LWB MODELS		Part Number	Qty	Note
Estimated Lift 40mm	Medium Load	Spring	2895	1
		Shock - N/Sport	*60004 / 60112	2 1,5
		Shock - N/Plus	*63004 / 63112	
	Constant 200kg	Spring	2896	1
		Shock - N/Sport	*60005 / 60004	2 1,5
		Shock - N/Plus	*63005 / 63004	
	Constant 400kg	Spring	2897	1
		Shock - N/Sport	60005	2 1,5
		Shock - N/Plus	63005	
	BP-51	Shock	BP5160025	2
		Fit Kit	VM80010010	1

Comments

- 1** To maintain front strut droop it is important front coils are selected as shown.
- 2** No top mounting bushes supplied use OME3133. OE bushes may be re-used if in good condition.
- 3** Strut Top Hat Kit may be required if original equipment is worn.
- 4** The OME Upper Control Arm will provide an increase between +2.5 and +3.5 degrees of caster and up to 1.5 degrees of negative camber increase (figures based off an approximate 50mm lift). Please note after fitment of Upper Control Arm a vehicle wheel alignment will be required.
- 5** OME661 Lower Shock Mount Stone Guard is recommended fitment to rear shocks to protect against severe stone peppering encountered on loose road surfaces.

REAR SELECTION

SWB MODELS		Part Number	Qty	Note
Estimated Lift 40mm	Medium Load	Spring	2895E	1
		Shock - N/Sport	*60004 / 60112	2 1,5
		Shock - N/Plus	*63004 / 63112	
	Constant 200kg	Spring	2895	1
		Shock - N/Sport	*60005 / 60004	2 1,5
		Shock - N/Plus	*63005 / 63004	
	Constant 400kg	Spring	2896	1
		Shock - N/Sport	60005	2 1,5
		Shock - N/Plus	63005	
	BP-51	Shock	BP5160025	2
		Fit Kit	VM80010010	1

FIT KITS & HARDWARE

Loc	Description	Part Number	Qty	Note
R	STONE GUARD KIT	OME661	1	5

FRONT SELECTION

DIESEL ENGINE			Part Number	Qty	Note
Estimated Lift 40mm	No Bar	Spring	2881	1	1
		Strut - N/Sport	90004	2	
	Bar Only	Spring	2882	1	1
		Strut - N/Sport	90004	2	
	Bar/ Winch/ Accessories	Spring	2882	1	1
		Strut - N/Sport	90004	2	
	Nitro +	Spring	4003	1	1
		Strut	93004	2	3

Comments

- 1 To maintain front strut droop it is important front coils are selected as shown.
- 2 OME661 Lower Shock Mount Stone Guard is recommended fitment to rear shocks to protect against severe stone peppering encountered on loose road surfaces.
- 3 Does not suit OE coil.

FRONT SELECTION

V6 PETROL ENGINE			Part Number	Qty	Note
Estimated Lift 40mm	No Bar	Spring	2880	1	1
		Strut - N/Sport	90004	2	
	Bar Only	Spring	2881	1	1
		Strut - N/Sport	90004	2	
	Bar/ Winch/ Accessories	Spring	2881	1	1
		Strut - N/Sport	90004	2	
	Nitro +	Spring	4006	1	1
		Strut	93004	2	3

FIT KITS & HARDWARE

Loc	Description	Part Number	Qty	Note
F	TRIM PACKER	OME95PF5	EA	

REAR SELECTION

ALL MODELS			Part Number	Qty	Note
Estimated Lift 40mm	Medium Load	Spring	2890	1	
		Shock - N/Sport	60028	2	2
		Shock - N/Plus	63028		
	Constant 150kg	Spring	2891	1	
		Shock - N/Sport	*60027 / 60028	2	2
		Shock - N/Plus	*63027 / 63028		
	Constant 300kg	Spring	2892	1	
		Shock - N/Sport	60027	2	2
		Shock - N/Plus	63027		

FIT KITS & HARDWARE

Loc	Description	Part Number	Qty	Note
R	TRIM PACKER	OME80PF05	EA	
		OME80PF10		
R	STONE GUARD KIT	OME661	1	2

FRONT SELECTION

DIESEL ENGINE		Part Number	Qty	Notes
Estimated Lift 40mm	No Bar	Spring	2884	1 1,3,4,5
		Strut - N/Sport	90028	2 2
	Bar Only	Spring	3176	1 1,3,4,5
		Strut - N/Sport	90028	2 2
	Bar/ Winch	Spring	3190	1 1,3,4,5
		Strut - N/Sport	90029	2 2
	Bar/ Winch/ Accessories	Spring	3177	1 1,3,4,5
		Strut - N/Sport	90029	2 2
	Nitro +	Spring	4000	1 1,3,4,5
		Strut - N/Plus	*93029 / 93028	2 2,6
	MT64	Spring	4000	1 1,3,4,5
		Strut - MT64	MT64901001	2 2,6

Comments

- 1** To maintain coil clearance from the sway bar, the coil seat must be installed with the helix facing away from the sway bar.
- 2** No top mount bushes supplied use OME3133. OE Bushes may be re-used if in good condition.
- 3** Strut Top Hat Kit may be required if original equipment is worn.
- 4** Australia Only. Full OME suspension system must be fitted.
- 5** The OME Upper Control Arm will provide an increase between +2.5 and +3.5 degrees of caster and upto 1.5 degrees of negative camber increase (figures based off an approximate 50mm lift). Please note after fitting a wheel alignment will be required.
- 6** Does not suit OE coil.

FRONT SELECTION

DIESEL ENGINE		Part Number	Qty	Note
Estimated Lift 20mm	No Bar	Spring	3114	1 1,3,4,5
		Strut - N/Sport	90028	2 2
	Bar Only	Spring	2885	1 1,3,4,5
		Strut - N/Sport	90028	2 2
	Bar/ Winch	Spring	2887	1 1,3,4,5
		Strut - N/Sport	90029	2 2
	Bar/ Winch/ Accessories	Spring	2888	1 1,3,4,5
		Strut - N/Sport	90029	2 2
	Nitro +	Spring	4007	1 1,3,4,5
		Strut - N/Plus	*93029 / 93028	2 2,6
	MT64	Spring	4007	1 1,3,4,5
		Strut - MT64	MT64901001	2 2,6
BP-51	Coilover LH	BP5190007L	1+1	
	Coilover RH	BP5190007R		
	Fit Kit	VM80010018	1	

FIT KITS & HARDWARE

Loc	Description	Part Number	Qty	Note
F	Upper Control Arms	UCA0003	1	5
F	Upper Strut Bushes	OME3133		2
F	Strut Top Hat Kit	OMETH002	Ea	3
F	Trim Packer	OME95PF5		
F	Front Axle Upgrade Kit	FAUHI1595		4

SERVICE PARTS

Description	Part #	Qty	Note
OME UCA Eye Bush 2pk	UCASP007	1	
OME UCA Ball Joint 1pk	UCASP008	EA	
OME UCA Boot 2pk	UCASP009	1	

REAR SELECTION

ALL MODELS		Part Number	Qty	Notes	
Estimated Lift 40mm	Medium Load	Spring Multi leaf	EL105R	2	1,4,5
		Shock - N/Sport	60132		
		Shock - N/Plus	63132	1+1	
		Shock - MT64	MT64601001L		
		Shock - MT64	MT64601001R		
	Constant 300kg	Spring Multi leaf	EL106R	2	1,4,5
		Shock - N/Sport	*60133 / 60132		
		Shock - N/Plus	*63133 / 63132	1+1	
		Shock - MT64	MT64601001L		
		Shock - MT64	MT64601001R		
		Shock - MT64	*MT64601002L		
	Shock - MT64	*MT64601002R			
	Constant 600kg	Spring Multi leaf	EL107R	2	1,4,5,6
		Shock - N/Sport	60133		
		Shock - N/Plus	63133	1+1	
		Shock - MT64	MT64601002L		
	BP-51	Shock LH	BP5160018L	1+1	8
		Shock RH	BP5160018R		
		Shock LH Heavy	*BP5160051L	1+1	8
		Shock RH Heavy	*BP5160051R		
Fit Kit		VM80010019	1		
Spring Bush	OMESB98	2			
U bolts	OMEU53A	4	5		
	OMEU53B				
Greasable Shackle	OMEGS25	1			
Greasable Pin	OMEGP9				

Comments

- * Heavier Valved shock option
- 1** Include tray weight in constant load calculation.
- 2** EL45XL will give approximately 20mm extra lift or increase loading capacity at design height by approximately 200kgs.
- 3** The Halogen Headlamp Levelling Bracket is a **mandatory** fitment for SR5 versions only.
- 4** Leaf Spring front eye bolt 6151539 required for fuel tank side and is available as a spare part. Refer to the Spare Parts Price List of pricing.
- 5** Use OMEU53A for EL105R & EL106R. Use OMEU53B for EL106R with extra leaf and EL107R.
- 6** When adding extra leaf to EL107R please add UCB4.
- 7** Refer to **Leaf Spring Service Parts** section for Centre Bolt selection.
- 8** Heavy Tune is suitable for 300kg springs & mandatory for 600kg springs.

FIT KITS & HARDWARE

Loc	Description	Part Number	Qty	Notes
R	Extra Leaf	EL45XL	1	2,6
R	Leaf Eye Bolt	6151539		4
R	Headlamp bracket	FK86		3
R	Trim Packer	ELSK05	Ea	
R	Extra Leaf spacer kit	ELSK12	2	
R	Centre Bolt		Ea	7

FRONT SELECTION

DIESEL ENGINE		Part Number	Qty	Notes	
Estimated Lift 30mm	No Bar	Spring	2883	1 1	
		Strut - N/Sport	*90002 / 90011	2 2	
	Bar Only	Spring	2884	1 1	
		Strut - N/Sport	90002	2 2	
	Bar/ Winch/ Accessories	Spring	2885	1 1	
		Strut - N/Sport	90002	2 2	
	Nitro +	Spring	4001	1 1	
		Strut - N/Plus	*93002 / 93011	2 2,7	
	BP-51	Strut LH	BP5190001L	1+1	
		Strut RH	BP5190001R		
Fit Kit		VM80010001	1		

Comments

- 1** To maintain coil clearance from the sway bar, the coil seat **must** be installed with the helix facing away from the sway bar.
- 2** No top mounting bushes supplied use OME3133. OE bushes may be re-used if in good condition.
- 3** Include tray weight in constant load calculation.
- 4** EL13XL will give approximately 22mm extra lift or increase loading capacity at design height by approximately 200kgs.

FRONT SELECTION

PETROL ENGINE		Part Number	Qty	Note	
Estimated Lift 30mm	No Bar	Spring	3058	1 1	
		Strut - N/Sport	*90002 / 90011	2 2	
	Bar Only	Spring	2883	1 1	
		Strut - N/Sport	*90002 / 90011	2 2	
	Bar/ Winch/ Accessories	Spring	2884	1 1	
		Strut - N/Sport	90002	2 2	
	Nitro +	Spring	4023	1 1	
		Strut - N/Plus	*93002 / 93011	2 2,7	
	BP-51	Coilover LH	BP5190001L	1+1	
		Coilover RH	BP5190001R		
Fit Kit		VM80010001	1		

- 5** Strut Top Hat Kit may be required if original equipment is worn.
- 6** The OME Upper Control Arm will provide an increase between +2.5 and +3.5 degrees of caster and up to 1.5 degrees of negative camber increase (figures based off an approximate 50mm lift). Please note after fitment of Upper Control Arm a vehicle wheel alignment will be required.
- 7** Does not suit OE coil.

FIT KITS & HARDWARE

Loc	Description	Part Number	Qty	Note
F	UPPER CONTROL ARMS	UCA0003	1	6
F	TRIM PACKER	OME95PF5		
F	UPPER STRUT BUSHES	OME3133	EA	2
F	STRUT TOP HAT KIT	OMETH002		5

SERVICE PARTS

Description	Part #	Qty	Note
OME UCA Eye Bush 2pk	UCASP007	1	
OME UCA Ball Joint 1pk	UCASP008	EA	
OME UCA Boot 2pk	UCASP009	1	

REAR SELECTION

ALL MODELS		Part Number	Qty	Notes	
Estimated Lift 40mm	Light Load	Spring Multi leaf	EL043R	2	3
		Shock - N/Sport	60006		
		Shock - N/Plus	63006		
	Medium Load	Spring Multi leaf	EL044R	2	3
		Shock - N/Sport	60006		
		Shock - N/Plus	63006		
	Constant 400kg	Spring Multi leaf	EL045R	2	3
		Shock - N/Sport	60007		
		Shock - N/Plus	63007		
	Constant 600kg	Spring Multi leaf	EL071R	2	3
		Shock - N/Sport	60007		
		Shock - N/Plus	63007		
	BP-51	Shock LH	BP5160024L	1+1	
		Shock RH	BP5160024R		
Fit Kit		VM80010002	1		
SPRING BUSH KIT		OMESB98	2	4	
U BOLT		OMEU53A	4		
GREASABLE SHACKLE KIT		OMEGS14	1		
GREASABLE FIXED END PIN KIT		OMEGP9			
BRAKE PROPORTIONING KIT		FK59			

FIT KITS & HARDWARE

Loc	Description	Part Number	Qty	Notes
R	EXTRA LEAF	EL13XL	2	4
R	TRIM PACKER	ELSK05	EA	
R	EXTRA LEAF SPACER KIT	ELSK12	2	
R	CENTRE BOLT		EA	7

Comments

1 To maintain coil clearance from the sway bar, the coil seat **must** be installed with the helix facing away from the sway bar.

2 No top mounting bushes supplied use OME3133. OE bushes may be re-used if in good condition.

3 Include tray weight in constant load calculation.

4 EL13XL will give approximately 22mm extra lift or increase loading capacity at design height by approximately 200kgs.

5 Strut Top Hat Kit may be required if original equipment is worn.

6 The OME Upper Control Arm will provide an increase between +2.5 and +3.5 degrees of caster and up to 1.5 degrees of negative camber increase (figures based off an approximate 50mm lift). Please note after fitment of Upper Control Arm a vehicle wheel alignment will be required.

7 Refer to **Leaf Spring Service Parts** section for Centre Bolt selection.

FRONT SELECTION

PETROL & DIESEL ENGINES		Part Number	Qty	Notes
Bar/ Winch/ Accessories	Torsion Bars	303003	1	1
	Shock - N/Sport	60042	2	
	Shock - N/Plus	63042		

FIT KITS & HARDWARE

Loc	Description	Part Number	Qty	Note
F	STEERING DAMPER	OMESD33	1	

REAR SELECTION

ALL MODELS		Part Number	Qty	Note	
Estimated Lift 50mm	Medium Load	Spring Multi Leaf	CS018R	2	3,5
		Shock - N/Sport	60043 + 60044	1+1	2
		Shock - N/Plus	63043 + 63044		
	Constant 120kg	Spring Multi Leaf	CS019R	2	3,5
		Shock - N/Sport	60043 + 60044	1+1	2
		Shock - N/Plus	63043 + 63044		
	Constant 250kg	Spring Multi Leaf	CS020R	2	3,5
		Shock - N/Sport	60043 + 60044	1+1	2
		Shock - N/Plus	63043 + 63044		
	Constant 400kg	Spring Multi Leaf	CS021R	2	3,5
		Shock - N/Sport	60043 + 60044	1+1	2
		Shock - N/Plus	63043 + 63044		
		SPRING BUSH KIT	OMESB43	2	
		GREASABLE SHACKLE KIT	OMEGS7	1	3
		GREASABLE FIXED END PIN KIT	OMEGP11		
	U BOLT	OMEU53A	4		
	FITTING KIT	FK01	1	4	

FIT KITS & HARDWARE

Loc	Description	Part Number	Qty	Note
R	ANTI INVERSION KIT	FK15	1	3
R	EXTRA LEAF	D6XL	2	6
R	CENTRE BOLT			7

Comments

- 1** Raise or lower front end clearance and trim vehicle by adjusting front torsion bars.
- 2** 60043 is longer in length and **must** be fitted to right hand side only. Fitment to left hand side may cause damage to shock absorber and vehicle.
- 3** **Mandatory** fitment: either OMEGS7 or FK15 Anti Inversion Kit required to prevent possible spring inversion.
- 4** Fitment of FK01 Spacer Washers to U Bolts is **required** to ensure correct tension is obtained on U Bolts.
- 5** Include tray weight in constant load calculation.
- 6** D6XL suitable for CS019R, CS020R and CS021R.
- 7** Refer to **Leaf Spring Service Parts** section for Centre Bolt selection.

FRONT SELECTION

DIESEL ENGINE		Part Number	Qty	Notes	
Est Lift 45mm	No Bar	Spring Multi leaf	CS009FA/B	1+1	1,2,3
		Shock - N/Sport	60061	2	
	Bar Only	Spring Multi leaf	CS009FA/B	1+1	1,2,3
		Shock - N/Sport	60061	2	
	Bar/ Winch/ Accessories	Spring Multi leaf	CS009FA/B	1+1	1,2,3
		Shock - N/Sport	60061	2	

Comments

- 1 A/A spring fitment may be needed on some vehicles for trimming purposes.
- 2 Petrol HiLux may require an FK03 (saddle correction plates) if the spring seats are distorted. FK10 must be fitted to all Diesel & Petrol Models used off road. Refer OME Technical & Fitting Manual.

FRONT SELECTION

PETROL ENGINE		Part Number	Qty	Notes	
Est Lift 45mm	No Bar	Spring Multi leaf	CS008FA/B	1+1	1,2,3
		Shock - N/Sport	60061	2	
	Bar Only	Spring Multi leaf	CS009FA/B	1+1	1,2,3
		Shock - N/Sport	60061	2	
	Bar/ Winch/ Accessories	Spring Multi leaf	CS009FA/B	1+1	1,2,3
		Shock - N/Sport	60061	2	

- 3 OMEU52 is required when fitting OME springs to stop the U Bolt contacting the drag link. Refer OME Technical & Fitting Manual. OMEU52 and OMEU53B for drivers side OMEU53 for passenger side.

- 4 A trim packer may be required to trim vehicle. Only to be used on rear springs.

FIT KITS & HARDWARE

Loc	Description	Part Number	Qty	Notes
F	SPRING BUSH KIT	OMESB5	2	
F	U BOLT	OMEU52 +	1 +	3
		OMEU53 +	2 +	
		OMEU53B	1	
F	FITTING KIT	FK03		2
F	GREASABLE SHACKLE KIT	OMEGS4	1	
F	GREASABLE FIXED END PIN KIT	OMEGP3		
F	STEERING DAMPER	OMESD21		
F	EXTRA LEAF	D17XL		
F	CENTRE BOLT		2	10

- 5 Post 1984 vehicles have a 19mm mounting pin and suit shock part numbers: ⁹N85, ⁹N94, ⁹60062 and 60065. Pre 1984 vehicles have a 16mm mounting pin and suit shock part numbers: ⁹N89, ⁹60032 and ⁹60064.

- 6 If greasable shackles are not fitted Anti Inversion Kits **must** be fitted. FK09 fits all pre 1984 Models. FK13 fits all 1985 Models On.

- 7 Include tray weight in constant load calculation. To provide correct shackle angle, 1985 - 89 automatic 4 Runner Models require the 3rd leaf to be removed to reduce spring rate.

REAR SELECTION

ALL MODELS		Part Number	Qty	Notes	
Estimated Lift 50mm	Medium Load	Spring Multi leaf	CS009R	4,6,7	
		Shock - N/Sport	*60065 / 60062	2	5,9
		Shock - N/Sport	*60064 / 60032		5,9
	Constant 250kg	Spring Multi leaf	CS010R		4,6,7
		Shock - N/Sport	60064	2	5,9
		Shock - N/Sport	60065		5
	U BOLT	OMEU53	4		
	SPRING BUSH KIT	OMESB6	2		
	GREASABLE SHACKLE KIT	OMEGS3	1		
	GREASABLE SHACKLE END PIN KIT	OMEGP3			

- 8 Only Suits CS008FA/B. Do not fit to CS009FA/B.

- 9 When remaining stock of N85, N89, N94, 60032, 60062 and 60064 is exhausted no further product will be available.

- 10 Refer to Leaf Spring Service Parts section for Centre Bolt selection.

FIT KITS & HARDWARE

Loc	Description	Part Number	Qty	Notes
R	TRIM PACKER	TP04	EA	4
R	ANTI INVERSION KIT	FK09	1	6
		FK13		
R	EXTRA LEAF	D5XL	2	
R	CENTRE BOLT			10

FRONT SELECTION

PETROL & DIESEL ENGINES		Part Number	Qty	Notes
Bar/ Winch/ Accessories	Torsion Bars	303003	1	1
	Shock - N/Sport	60072	2	
	Shock - N/Plus	63072		

FIT KITS & HARDWARE

Loc	Description	Part Number	Qty	Note
F	STEERING DAMPER	OMESD33	1	

REAR SELECTION^b

ALL MODELS		Part Number	Qty	Note	
Estimated Lift 50mm	Medium Load	Spring Multi Leaf	CS019R	2	2,3
		Shock - N/Sport	60065		
		Shock - N/Plus	63065		
	Constant 200kg	Spring Multi Leaf	CS020R	2	2,3
		Shock - N/Sport	60065		
		Shock - N/Plus	63065		
		SPRING BUSH KIT	OMESB43	2	
		U BOLT	OMEU53	4	2
			OMEU53B		
		GREASABLE SHACKLE KIT	OMEGS7	1	
	GREASABLE FIXED END PIN KIT	OMEGP11			

FIT KITS & HARDWARE

Loc	Description	Part Number	Qty	Note
R	EXTRA LEAF	D6XL	2	
R	CENTRE BOLT			4

Comments

- 1** Raise or lower front end clearance and trim vehicle by adjusting front torsion bars.
- 2** Compare original spring stack height to OME spring stack to decide whether OMEU53 or OMEU53B U Bolts are required.
- 3** Include tray weight in constant load calculation.
- 4** Refer to **Leaf Spring Service Parts** section for Centre Bolt selection.
- 5** When remaining stock of N85 and N94 is exhausted no further product will be available.

FRONT SELECTION

PETROL & DIESEL ENGINES		Part Number	Qty	Notes
Bar/ Winch/ Accessories	Torsion Bars	303003	1	1
	Shock - N/Sport	60072	2	
	Shock - N/Plus	63072		

Comments

1 Raise or lower front end clearance and trim vehicle by adjusting front torsion bars.

2 When remaining stock of N72F is exhausted no further product will be available.

FIT KITS & HARDWARE

Loc	Description	Part Number	Qty	Note
F	STEERING DAMPER	OMESD33	1	

REAR SELECTION

ALL MODELS		Part Number	Qty	Note	
Estimated Lift 50mm	Medium Load	Coil Spring	2900	1	
		Shock - N/Sport	60073	2	
		Shock - N/Plus	63073		
	Constant 200kg	Coil Spring	2901	1	
		Shock - N/Sport	60073	2	2
		Shock - N/Plus	63073		

4 RUNNER 1986 TO 1990 IFS REAR LEAF SPRING MODELS (TO 1989 IN USA)

GLOBAL

FRONT SELECTION

PETROL & DIESEL ENGINES		Part Number	Qty	Notes
Bar/ Winch/ Accessories	Torsion Bars	303003	1	1
	Shock - N/Sport	60072	2	
	Shock - N/Plus	63072		

FIT KITS & HARDWARE

Loc	Description	Part Number	Qty	Note
F	STEERING DAMPER	OMESD33	1	

REAR SELECTION⁵

ALL MODELS		Part Number	Qty	Note	
Estimated Lift 50mm	Medium Load	Spring Multi Leaf	CS009R	2,3	
		Shock - N/Sport	60065	2	
		Shock - N/Plus	63065		
	Constant 200kg	Spring Multi Leaf	CS010R	2,3	
		Shock - N/Sport	60065	2	
		Shock - N/Plus	63065		
	SPRING BUSH KIT		OMESB6	2	
	U BOLT		OMEU53	4	2
			OMEU53B		
	GREASABLE SHACKLE KIT		OMEGS3	1	
GREASABLE FIXED END PIN KIT		OMEGP3			

FIT KITS & HARDWARE

Loc	Description	Part Number	Qty	Note
R	EXTRA LEAF	D5XL	2	
R	CENTRE BOLT			4

Comments

- 1** Raise or lower front end clearance and trim vehicle by adjusting front torsion bars.
- 2** Compare original spring stack height to OME spring stack to decide whether OMEU53 or OMEU53B U Bolts are required.
- 3** Install OE caster wedges from OE spring stack onto OME springs. Ensure wedges are fitted as per original position.
- 4** Refer to **Leaf Spring Service Parts** section for Centre Bolt selection.
- 5** When remaining stock of N85 and N94 is exhausted no further product will be available.

FRONT SELECTION

V6 4.0L PETROL ENGINE		Part Number	Qty	Notes	
Estimated Lift 50mm	No Bar	Spring	2883	1	1
		Strut - N/Sport	90010	2	2
	Bar Only	Spring	2884	1	1
		Strut - N/Sport	90010	2	2
	Bar/ Winch/ Accessories	Spring	2885	1	1
		Strut - N/Sport	90010	2	2
	Nitro +	Spring	4001	1	1
		Strut - N/Plus	93010	2	2,6
	MT64	Spring	4001	1	
		Strut - N/Plus	MT64901007	2	
	BP-51 NON KDSS	Strut LH	BP5190002L	1+1	
		Strut RH	BP5190002R		
		Fit Kit	VM80010028	1	
	BP-51 SUITS KDSS	Strut LH	BP5190004L	1+1	
Strut RH		BP5190002R			
Fit Kit		VM80010009	1		

Comments

- 1 Vehicles with KDSS, must have 1 x OME95PF5 packer installed on the front right hand side to maintain correct trim.
- 2 No top mounting bushes supplied use OME3133. OE bushes may be re-used if in good condition.
- 3 OME661 Lower Shock Mount Stone Guard is recommended fitment to rear shocks to protect against severe stone peppering encountered on loose road surfaces.
- 4 Strut Top Hat Kit may be required if original equipment is worn.
- 5 The OME Upper Control Arm will provide an increase between +2.5 and +3.5 degrees of caster and up to 1.5 degrees of negative camber increase (figures based off an approximate 50mm lift). Please note after fitment of Upper Control Arm a vehicle wheel alignment will be required.
- 6 Does not suit OE coil.

FIT KITS & HARDWARE

Loc	Description	Part Number	Qty	Note
F	UPPER CONTROL ARMS	UCA0003	1	5
F	TRIM PACKER	OME95PF5	EA	1
F	UPPER STRUT BUSHES	OME3133	2	2
F	STRUT TOP HAT KIT	OMETH002		4

REAR SELECTION

LWB MODEL		Part Number	Qty	Note	
Estimated Lift 50mm	Medium Load	Spring	2895	1	3
		Shock - N/Sport	60080	2	
		Shock - N/Plus	63080		
		Shock - MT64	MT64601009		
	Constant 200kg	Spring	2896	1	3
		Shock - N/Sport	*60081 / 60080	2	
		Shock - N/Plus	*63081 / 63080		
		Shock - MT64	MT64601009		
		Shock - MT64	*MT64601010		
	Shock - MT64	*MT64601010			
	Constant 400kg	Spring	2897	1	3
		Shock - N/Sport	60081	2	
		Shock - N/Plus	63081		
		Shock - MT64	MT64601010		
Shock - MT64	MT64601010				
BP-51	Shock	BP5160025	2		
	Fit Kit	VM80010010	1		

FIT KITS & HARDWARE

Loc	Description	Part Number	Qty	Note
R	TRIM PACKER	OME150PR10	EA	3
R	STONE GUARD KIT	OME661	1	

SERVICE PARTS

Description	Part #	Qty	Note
OME UCA Eye Bush 2pk	UCASP007	1	
OME UCA Ball Joint 1pk	UCASP008	EA	
OME UCA Boot 2pk	UCASP009	1	

FRONT SELECTION - Estimated Lift 25-50mm

ALL MODELS		Part Number	Qty	Notes
No Bar	Spring	2884	1	1
	Strut - N/Sport	90000	2	2
Bar/ Winch/ Accessories	Spring	2885	1	1
	Strut - N/Sport	90000	2	2
Nitro +	Spring	4001	1	1
	Strut - N/Plus	93000	2	2,5

FIT KITS & HARDWARE

Loc	Description	Part Number	Qty	Note
F	UPPER CONTROL ARMS	UCA0004	1	4
F	TRIM PACKER	OME95PF5	EA	1
F	UPPER STRUT BUSHES	OME3133	2	2
F	STRUT TOP HAT KIT	OMETH002		3

REAR SELECTION

ALL MODELS		Part Number	Qty	Note
Estimated Lift 50mm	Medium Load	Spring	2895	1
		Shock - N/Sport	60004	2
		Shock - N/Plus	63004	
	Constant 150kg	Spring	2896	1
		Shock - N/Sport	*60005 / 60004	2
		Shock - N/Plus	*63005 / 63004	
	Constant 300kg	Spring	2897	1
		Shock - N/Sport	60005	2
		Shock - N/Plus	63005	

FIT KITS & HARDWARE

Loc	Description	Part Number	Qty	Note
R	STONE GUARD KIT	OME661	1	

SERVICE PARTS

Description	Part #	Qty	Note
OME UCA Eye Bush 2pk	UCASP010	1	
OME UCA Ball Joint 1pk	UCASP002	EA	
OME UCA Boot 2pk	UCASP011	1	

Comments

- 1 OME front coils can only be installed with OME Nitrocharger strut and coil seats.
- 2 No top mounting bushes supplied use OME3133. OE bushes may be re-used if in good condition.
- 3 Strut Top Hat Kit may be required if original equipment is worn.
- 4 The OME Upper Control Arm will provide an increase between +2.5 and +3.5 degrees of caster and up to 1.5 degrees of negative camber increase (figures based off an approximate 50mm lift). Please note after fitment of Upper Control Arm a vehicle wheel alignment will be required.
- 5 Does not suit OE coil.

FRONT SELECTION - Estimated Lift 30mm

PETROL & DIESEL ENGINES		Part Number	Qty	Notes
Bar Only	Coil Spring	2880	1	
	Strut - N/Sport	90004	2	
Bar/ Winch/ Accessories	Coil Spring	2881	1	
	Strut - N/Sport	90004	2	
Nitro +	Spring	4006	1	
	Strut	93004	2	1

Comments

1 Does not suit OE coil.

REAR SELECTION - Estimated Lift 50mm

ALL MODELS		Part Number	Qty	Note
Medium Load	Coil Spring	2906	1	
	Shock - N/Sport	*60027 / 60028	2	
	Shock - N/Plus	*63027 / 63028		
Constant 250kg	Coil Spring	2890	1	
	Shock - N/Sport	*60027 / 60028	2	
	Shock - N/Plus	*63027 / 63028		

FRONT SELECTION

ALL MODELS		Part Number	Qty	Note
Estimated Lift 50mm	No Bar	Spring	2883	1
		Strut - N/Sport	*90010 / 90016	2 1
	Bar Only	Spring	2884	1
		Strut - N/Sport	90010	2 1
	Bar/ Winch/ Accessories	Spring	2885	1
		Strut - N/Sport	90010	2 1
	Nitro +	Spring	4007	1
		Strut	*93010 / 93016	2 1,5
	MT64	Spring	4007	1
		Strut	MT64901007	2 1,5
	BP-51	Strut - LH	BP5190002L	1+1
		Strut - RH	BP5190002R	
Fit Kit		VM80010008	1	

Comments

- 1** No top mounting bushes supplied use OME3133. OE bushes may be re-used if in good condition.
- 2** OME661 lower shock mount guard is recommended fitment to rear shocks to protect against severe stone peppering encountered on loose road surfaces.
- 3** Strut Top Hat Kit may be required if original equipment is worn.
- 4** The OME Upper Control Arm will provide an increase between +2.5 and +3.5 degrees of caster and up to 1.5 degrees of negative camber increase (figures based off an approximate 50mm lift). Please note after fitment of Upper Control Arm a vehicle wheel alignment will be required.

FIT KITS & HARDWARE

Loc	Description	Part Number	Qty	Note
F	UPPER CONTROL ARM	UCA0004	1	4
F	TRIM PACKER	OME95PF5	EA	
F	UPPER STRUT BUSHES	OME3133	2	1
F	STRUT TOP HAT KIT	OMETH002		3

- 5** Does not suit OE coil.

REAR SELECTION

ALL MODELS		Part Number	Qty	Note
Estimated Lift 50mm	Light Load	Spring	2895E	1
		Shock - N/Sport	*60080 / 60086	2 2
		Shock - N/Plus	*63080 / 63086	
		Shock - MT64	MT64601011	
	Medium Load	Spring	2895	1
		Shock - N/Sport	*60081 / 60080	2 2
		Shock - N/Plus	*63081 / 63080	
		Shock - MT64	MT64601011	
		Shock - MT64	*MT64601009	
	Constant 200kg	Spring	2896	1
		Shock - N/Sport	60081	2 2
		Shock - N/Plus	63081	
		Shock - MT64	MT64601009	
	BP-51	Shock	BP5160025	2
		Fit Kit	VM80010010	1

FIT KITS & HARDWARE

Loc	Description	Part Number	Qty	Note
R	STONE GUARD KIT	OME661	1	2

SERVICE PARTS

Description	Part #	Qty	Note
OME UCA Eye Bush 2pk	UCASPO10	1	
OME UCA Ball Joint 1pk	UCASPO02	EA	
OME UCA Boot 2pk	UCASPO11	1	

FRONT SELECTION

ALL MODELS		Part Number	Qty	Note
Estimated Lift 50mm	No Bar	Spring	2883	1
		Strut - N/Sport	*90000 / 90021	2 1
	Bar Only	Spring	2884	1
		Strut - N/Sport	90000	2 1
	Bar/ Winch/ Accessories	Spring	2885	1
		Strut - N/Sport	90000	2 1
	Nitro +	Spring	4007	1
		Strut - N/Plus	93000	2 1,5

Comments

- 1 No top mounting bushes supplied use OME3133. OE bushes may be re-used if in good condition.
- 2 OME661 lower shock mount guard is recommended fitment to rear shocks to protect against severe stone peppering encountered on loose road surfaces.
- 3 Strut Top Hat Kit may be required if original equipment is worn.
- 4 The OME Upper Control Arm will provide an increase between +2.5 and +3.5 degrees of caster and up to 1.5 degrees of negative camber increase (figures based off an approximate 50mm lift). Please note after fitment of Upper Control Arm a vehicle wheel alignment will be required.
- 5 Does not suit OE coil.

FIT KITS & HARDWARE

Loc	Description	Part Number	Qty	Note
F	UPPER CONTROL ARM	UCA0004	1	4
F	TRIM PACKER	OME95PF5	EA	
F	UPPER STRUT BUSHES	OME3133	2	1
F	STRUT TOP HAT KIT	OMETH002		3

REAR SELECTION

ALL MODELS		Part Number	Qty	Note
Estimated Lift 50mm	Light Load	Spring	2895E	1
		Shock - N/Sport	*60004 / 60112	2 2
		Shock - N/Plus	*63004 / 63112	
	Medium Load	Spring	2895	1
		Shock - N/Sport	*60004 / 60112	2 2
		Shock - N/Plus	*63004 / 63112	
	Constant 200kg	Spring	2896	1
		Shock - N/Sport	60081	2 2
		Shock - N/Plus	63081	

FIT KITS & HARDWARE

Loc	Description	Part Number	Qty	Note
R	STONE GUARD KIT	OME661	1	2

SERVICE PARTS

Description	Part #	Qty	Note
OME UCA Eye Bush 2pk	UCASP010	1	
OME UCA Ball Joint 1pk	UCASP002	EA	
OME UCA Boot 2pk	UCASP011	1	

FRONT SELECTION

DIESEL ENGINE			Part Number	Qty	Note
Estimated Lift 35mm	No Bar	Spring	2869	1	1
		Strut - N/Sport	90028	2	2
	Bar Only	Spring	2884	1	1
		Strut - N/Sport	90028	2	2
	Bar/ Winch	Spring	2885	1	1
		Strut - N/Sport	90029	2	2
	Bar/ Winch/ Accessories	Spring	2887	1	1
		Strut - N/Sport	90029	2	2
	Nitro +	Spring	4005	1	1
		Strut	93029	2	2,5

Comments

- 1 To maintain coil clearance from the Sway Bar, the coil seat must be installed with the helix facing away from the sway bar.
- 2 No top mounting bushes supplied use OME3133. OE bushes may be re-used if in good condition.
- 3 Strut Top Hat Kit may be required if original equipment is worn.
- 4 FK29 Rear Driveshaft Spacer is a **mandatory** fitment.
- 5 Does not suit OE coil.

FIT KITS & HARDWARE

Loc	Description	Part Number	Qty	Note
F	TRIM PACKER	OME95PF5	1	
F	UPPER STRUT BUSHES	OME3133	EA	2
F	STRUT TOP HAT KIT	OMETH002	2	3

REAR SELECTION

ALL MODELS			Part Number	Qty	Note
Est Lift 25mm	Medium Load	Spring	2802	1	
		Shock - N/Sport	60141	2	2
		Shock - N/Plus	63141		
	Constant 200kg	Spring	2803	1	
		Shock - N/Sport	60142	2	2
		Shock - N/Plus	63142		
	REAR DRIVESHAFT SPACER			FK29	1

FRONT SELECTION

DIESEL ENGINE			Part Number	Qty	Note
Est Lift 35mm	Bar Only	Spring	2883	1	
		Strut - N/Sport	*90002 / 90011	2	1
	Bar/ Winch/ Accessories	Spring	2884	1	
		Strut - N/Sport	*90002 / 90011	2	1
	Nitro +	Spring	4001	1	
		Strut	*93002 / 93011	2	1,3

Comments

- 1 No top mounting bushes supplied use OME3133. OE bushes may be re-used if in good condition.
- 2 Strut Top Hat Kit may be required if original equipment is worn.
- 3 Does not suit OE coil.

FIT KITS & HARDWARE

Loc	Description	Part Number	Qty	Note
F	TRIM PACKER	OME95PF5	1	
F	UPPER STRUT BUSHES	OME3133	EA	1
F	STRUT TOP HAT KIT	OMETH002	2	2

REAR SELECTION

ALL MODELS			Part Number	Qty	Note
Est Lift 25mm	Medium Load	Spring	2802	1	
		Shock - N/Sport	60078	2	
		Shock - N/Plus	63078		
	Constant 200kg	Spring	2803	1	
		Shock - N/Sport	60077	2	
		Shock - N/Plus	63078		

FRONT SELECTION

DIESEL ENGINE		Part Number	Qty	Note
Estimated Lift 60mm	No Bar	Spring	2612	1
		Strut - N/Sport	90018	2 1
	Bar Only	Spring	2614	1
		Strut - N/Sport	90018	2 1
	Bar/ Winch/ Accessories	Spring	2613	1
		Strut - N/Sport	90018	2 1
	Nitro +	Spring	4017	1
		Strut	93018	2 1,6
	BP-51	Strut - LH	BP5190010L	1+1
		Strut - RH	BP5190010R	
Fit Kit		VM80010034	1	

Comments

- 1** No top mounting bushes supplied, re-use OE bushes.
- 2** Models with rear sway bar will require end link modifications to retain sway bar in operation.
- 3** FK32 Brake Line and ABS Wire Bracket Relocation Kit is a mandatory fitment.
- 4** Please note CS055R is supplied with bushes installed.
- 5** Only fit Greasable Shackle Kit if fitting OMESB106.
- 6** Does not suit OE coil.

REAR SELECTION

ALL MODELS		Part Number	Qty	Note	
Estimated Lift 60mm	Medium Load	Multi Leaf Spring	CS055R	2,4	
		Shock - N/Sport	60100	2	
		Shock - N/Plus	63100		
	BP-51	Shock - LH	BP5160020L	1+1	
		Shock - RH	BP5160020R		
		Fit Kit	VM80010035	1	
	SPRING BUSH KIT		OMESB106	2	4,5
	U BOLT		OMEU53B	4	
	FITTING KIT		FK32	1	3
	GREASABLE SHACKLE KIT		OMEGS22	1	5

FIT KITS & HARDWARE

Loc	Description	Part Number	Qty	Note
R	XL LEAF	D28XL	2	

FRONT SELECTION

ALL MODELS		Part Number	Qty	Notes
Estimated Lift 50mm	No Bar	Coil Spring	2887	1
		Shock - N/Sport	90021	2 1
	Bar Only	Coil Spring	2888	1
		Shock - N/Sport	*90000 / 90021	2 1
	Bar/ Winch/ Accessories	Coil Spring	2886	1
		Shock - N/Sport	90000	2 1
	Nitro +	Coil Spring	4004	1
		Shock	93000	2 1,6
	MT64	Coil Spring	4004	1
		Shock	MT64901011	2 1,6
		Fit Kit	VM80010056	1 7
	BP-51	Strut LH	BP5190006L	1+1
Strut RH		BP5190006R		
Fit Kit		VM80010016	1	

Comments

- 1** No top mounting bushes supplied, use OME3133. OE bushes may be re-used if in good condition.
- 2** Strut Top Hat Kit may be required if original equipment is worn.
- 3** Two (2) Greasable Pin Kits required. One (1) kit for front fixed eye and one (1) kit for shackle pin for leaf spring eye.
- 4** The OME Upper Control Arm will provide an increase between +2.5 and +3.5 degrees of caster and up to 1.5 degrees of negative camber increase (figures based off an approximate 50mm lift). Please note after fitment of Upper Control Arm a vehicle wheel alignment will be required.

FIT KITS & HARDWARE

Loc	Description	Part Number	Qty	Notes
F	UPPER CONTROL ARM	UCA0005	1	4
F	TRIM PACKER	OME95PF5	EA	
F	UPPER STRUT BUSHES	OME3133	2	1
F	STRUT TOP HAT KIT	OMETH002		2

5 Refer to **Leaf Spring Service Parts** section for Centre Bolt selection.

6 Does not suit OE coil.

7 Fit kit is required for vehicles with MT64's set to "-5mm" (lowest) or "No Bar" (2nd Lowest) on the spring seat groove to stop fouling on the sway bar. Not required for "Bar Only" & above.

REAR SELECTION

ALL MODELS		Part Number	Qty	Notes
Estimated Lift 50mm	Medium Load	Spring Multi leaf	EL111R	
		Shock - N/Sport	60091	2
		Shock - N/Plus	63091	
		Shock - MT64	MT64601013L/R	1+1
	Constant 300kg	Spring Multi leaf	EL112R	
		Shock - N/Sport	60091	2
		Shock - N/Plus	63091	
		Shock - MT64	MT64601014L/R	1+1
	BP-51	Shock LH	BP5160011L	1+1
		Shock RH	BP5160011R	
		Fit Kit	VM80010017	1
	GREASABLE PIN KIT		OMEGP9	1
U BOLT		OMEU53B	4	
SPRING BUSH KIT		OMESB108	2	
DRIVESHAFT SPACER KIT		FK29	1	

FIT KITS & HARDWARE

Loc	Description	Part Number	Qty	Notes
R	EXTRA LEAF	EL46XL	2	
R	CENTRE BOLT		2	5

SERVICE PARTS

Description	Part #	Qty	Note
OME UCA Eye Bush 2pk	UCASP012	1	
OME UCA Ball Joint 1pk	UCASP013	EA	
OME UCA Boot 2pk	UCASP014	1	

FRONT SELECTION

ALL MODELS		Part Number	Qty	Notes
Estimated Lift 50mm	No Bar	Coil Spring	2885	1
		Shock - N/Sport	*90000 / 90021	2 1
	Bar/ Winch/ Accessories	Coil Spring	2886	1
		Shock - N/Sport	90000	2 1
	Nitro +	Coil Spring	4002	1
		Shock	93000	2 1,6
	MT64	Coil Spring	4002	1
		Shock	MT64901007	2 1,6
	BP-51	Strut LH	BP5190006L	1+1
		Strut RH	BP5190006R	
Fit Kit		VM80010016	1	

Comments

- 1** No top mounting bushes supplied, use OME3133. OE bushes may be re-used if in good condition.
- 2** Strut Top Hat Kit may be required if original equipment is worn.
- 3** Two (2) Greasable Pin Kits required. One (1) kit for front fixed eye and one (1) kit for shackle pin for leaf spring eye.
- 4** The OME Upper Control Arm will provide an increase between +2.5 and +3.5 degrees of caster and up to 1.5 degrees of negative camber increase (figures based off an approximate 50mm lift). Please note after fitment of Upper Control Arm a vehicle wheel alignment will be required.
- 5** Refer to **Leaf Spring Service Parts** section for Centre Bolt selection.
- 6** Does not suit OE coil.

FIT KITS & HARDWARE

Loc	Description	Part Number	Qty	Notes
F	UPPER CONTROL ARM	UCA0005	1	4
F	UPPER STRUT BUSHES	OME3133	2	1
F	STRUT TOP HAT KIT	OMETH002	1	2

REAR SELECTION

ALL MODELS		Part Number	Qty	Notes	
Estimated Lift 50mm	Medium Load	Spring Multi leaf	EL111R	2	
		Shock - N/Sport	60091		
		Shock - N/Plus	63091		
		Shock - MT64	MT64601013L/R	1+1	
	Constant 300kg	Spring Multi leaf	EL112R	2	
		Shock - N/Sport	60091		
		Shock - N/Plus	63091		
		Shock - MT64	MT64601014L/R	1+1	
	BP-51	Shock LH	BP5160011L	1+1	
		Shock RH	BP5160011R		
		Fit Kit	VM80010017	1	
	GREASABLE PIN KIT		OMEGP9	1	3
	U BOLT		OMEU53B	4	
	SPRING BUSH KIT		OMESB108	2	
DRIVESHAFT SPACER KIT		FK29	1		

FIT KITS & HARDWARE

Loc	Description	Part Number	Qty	Notes
R	EXTRA LEAF	EL46XL	2	
R	CENTRE BOLT			5

SERVICE PARTS

Description	Part Number	Qty	Note
OME UCA Eye Bush 2pk	UCASP012	1	
OME UCA Ball Joint 1pk	UCASP013	EA	
OME UCA Boot 2pk	UCASP014	1	

FRONT SELECTION

ALL MODELS		Part Number	Qty	Notes
Est Lift 45mm	No Bar	Coil Spring	2880	1
		Shock - N/Sport	90004	2
	Bar/ Winch/ Accessories	Coil Spring	2881	1
		Shock - N/Sport	90004	2
	Nitro +	Coil Spring	4006	1
		Shock - N/Plus	93004	2

Comments

1 FK21 Exhaust Bracket is **mandatory** fitment to ensure exhaust system clears springs.

2 Refer to **Leaf Spring Service Parts** section for Centre Bolt selection.

3 Does not suit OE coil.

REAR SELECTION

ALL MODELS		Part Number	Qty	Notes	
Est Lift 55mm	Medium Load	Spring Multi leaf	EL122RA/B	1+1	1
		Shock - N/Sport	*60065 / 60062	2	
		Shock - N/Plus	*63065 / 63062		
	U BOLT	OMEU53A	4		
	SPRING BUSH KIT	OMESB121	2		
	GREASABLE SHACKLE KIT	OMEGS12	1		
	EXHAUST BRACKET KIT	FK21		1	

FIT KITS & HARDWARE

Loc	Description	Part Number	Qty	Notes
R	EXTRA LEAF	D43XL	2	
R	CENTRE BOLT		EA	2

FRONT SELECTION

ALL MODELS		Part Number	Qty	Notes
Estimated Lift 40mm	No Bar	Spring	3207	1
		Strut - N/Sport	90052	2 1,11,13
	Bar Only	Spring	3208	1
		Strut - N/Sport	*90053 / 90052	2 1,11,13
Bar/ Winch	Spring	3209	1	
	Strut - N/Sport	90053	2 1,11,13	
Bar/ Winch/ Accessories	Spring	3210	1	
	Strut - N/Sport	90053	2 1,11,13	
20mm	No Bar	Spring	3211	1
		Strut - N/Sport	90052	2 1,11,13
Est Lift 20-40mm	Nitrocharger +	Spring - 40mm	4024	1
		Spring - 20mm	4028	
		Strut	*93053/ 93052	2 1,11,13
	MT-64	Spring - 40mm	4024	1
		Spring - 20mm	4028	
		Shock Shock Heavy	MT64902001 MT64902002	2
	BP-51	Strut - RH	BP5190015R	1
Strut - LH		BP5190015L		
Fit Kit		VM80010053		

FIT KITS & HARDWARE

Loc	Description	Part Number	Qty	Note
F	Upper Control Arm	UCA0009	1	
F	Trim Packer	FK112	EA	2

Comments

- 1 OMESB117 suits OE Shackle
OMESB118 bush kit suits OME Greasable shackle OMEGS20
- 2 Use OMEU82 when fitting EL130R/ EL131R
Use OMEU83 when fitting EL132R
- 3 Fitment of Driveline Spacer Kit FK113 is recommended to re-align driveline.
- 4 EL48XL will give approximately 30mm extra lift or increase loading capacity at design height by approximately 300kg.
- 5 FK114 only required for vehicles fitted with upgraded auto levelling head lights.
- 6 FK115 Bump Stop Adapter Kit is optional but highly recommended to save fitment time
- 7 FK116 Diff Breather Extension Kit only required for vehicles fitted with Ad Blue (Europe Only - for other markets check vehicle specs)
- 8 FK95 is a recommended fitment if original leaf spring fixed eye nut bolts are in poor condition. Ensure correct torque specifications are used in supplied fitting instructions.
- 9 Use 60178/ 63178 when adding an EL48XL Extra Leaf to a EL132R Leaf Spring or when carrying constant loads of 800kg and above. EL48XL will give an extra 250-300kg carrying capacity or 20-25mm lift.
- 10 Refer to **Leaf Spring Service Parts** section for Centre Bolt selection.
- 11 Spring selection based on Summit bar. If fitting a Sahara Bar please select down one spring.
- 12 Does not suit OE coil

REAR SELECTION

ALL MODELS		Part Number	Qty	Note	
Estimated Lift 40mm	Medium Load	Leaf Spring	EL130R	2,8,12	
		Shock - N/Sport	60172	2	
		Shock - N/Plus	63172		
		Shock - MT64	MT64602003L	1+1	
		Shock - MT64	MT64602003R		
	Constant 300kg	Leaf Spring	EL131R	2,8,12	
		Shock - N/Sport	*60173 / 60172	2	
		Shock - N/Plus	*63173 / 63172		
		Shock - MT64	MT64602003L	1+1	
		Shock - MT64	MT64602003R		
		Shock - MT64	*MT64602004L		
	Constant 600kg	Leaf Spring	EL132R	2,8,12	
		Shock - N/Sport	*60178 / 60173	2	
		Shock - N/Plus	*63178 / 63173	9	
		Shock - MT64	MT64602004L	1+1	
	BP-51	Shock - RH	BP5160055R		
		Shock - LH	BP5160055L	1	
		Fit Kit	VM80010052		
	Greasable Shackle Kit		OMEGS20	1	
	Greasable Pin Kit		OMEGP10		
Spring Bush Kit		OMESB117	2	1	
		OMESB118			
U-Bolts		OMEU82	4	2	
		OMEU83			
Extra Leaf		EL48XL		9	
Extra Leaf Spacer Kit		ELSK15	2		
Centre Bolt				10	

FIT KITS & HARDWARE

Loc	Description	Part Number	Qty	Note
R	Driveline Spacer Kit	FK113		3
R	Headlight Sensor Bracket	FK114	1	5
R	Bump Stop Adapter Kit	FK115		6
R	Diff Breather Extension Kit	FK116		7
R	Trim Packer	ELSK14	EA	
R	Leaf Spring Front Eye Bolt	FK95		8

Comments

- OMESB117 suits OE Shackle
OMESB118 bush kit suits OME Greasable shackle OMEGS20
- Use OMEU82 when fitting EL130R/ EL131R
Use OMEU83 when fitting EL132R
- Fitment of Driveline Spacer Kit FK113 is recommended to re-align driveline.
- EL48XL will give approximately 30mm extra lift or increase loading capacity at design height by approximately 300kg.
- FK114 only required for vehicles fitted with upgraded auto levelling head lights.
- FK115 Bump Stop Adapter Kit is optional but highly recommended to save fitment time
- FK116 Diff Breather Extension Kit only required for vehicles fitted with Ad Blue (Europe Only - for other markets check vehicle specs)
- FK95 is a recommended fitment if original leaf spring fixed eye nut bolts are in poor condition. Ensure correct torque specifications are used in supplied fitting instructions.
- Use 60178/ 63178 when adding an EL48XL Extra Leaf to a EL132R Leaf Spring or when carrying constant loads of 800kg and above. EL48XL will give an extra 250-300kg carrying capacity or 20-25mm lift.
- Refer to **Leaf Spring Service Parts** section for Centre Bolt selection.
- Spring selection based on Summit bar. If fitting a Sahara Bar please select down one spring.
- Does not suit OE coil

FRONT SELECTION

V6 DIESEL ENGINE		Part Number	Qty	Note
Estimated Lift 20mm	No Bar	Spring	3080	1 6
		Strut - N/Sport	90013	2 1,7,8
	Bar Only	Spring	3115	1
		Strut - N/Sport	90013	2 1,7,8
	Bar/ Winch/ Accessories	Spring	3116	1
		Strut - N/Sport	90013	2 1,7,8
	Nitro +	Spring	4033	1
		Strut - N/Sport	93013	2 1,7,8,10

FRONT SELECTION

4CYL DIESEL ENGINE		Part Number	Qty	Note
Estimated Lift 20mm	No Bar	Spring	3079	1
		Strut - N/Sport	90012	2 1,7,8
	Bar Only	Spring	3080	1 6
		Strut - N/Sport	90013	2 1,7,8
	Bar/ Winch/ Accessories	Spring	3080	1 6
		Strut - N/Sport	90013	2 1,7,8
	Nitro +	Spring	4034	1
		Strut - N/Plus	93013* / 93012	2 1,7,8,10

FIT KITS & HARDWARE

Loc	Description	Part Number	Qty	Note
F	UPPER CONTROL ARM (2010 To 2022)	UCA0008		
F	TRIM PACKER	OME95PF5	EA	2,6

REAR SELECTION

ALL MODELS		Part Number	Qty	Note	
Estimated Lift 20mm	Medium Load	Multi Leaf Spring	CS064R	3	
		Shock - N/Sport	60082	2 4	
		Shock - N/Plus	63082	4	
	Constant 400kg	Multi Leaf Spring	CS065R	3	
		Shock - N/Sport	60083	2 4	
		Shock - N/Plus	63083	4	
	SPRING BUSH KIT		OMESB104	2	3
	STONE GUARD KIT		OME665	1	4
	U BOLT	Medium Load	OMEU59A	4	
		Constant 400kg	OMEU59B		

FIT KITS & HARDWARE

Loc	Description	Part Number	Qty	Note
R	EXTRA LEAF	D38XL	2	5
R	CENTRE BOLT		EA	9

Comments

1 Top mount bump stop & bushes not supplied, re-use OE items.

2 For trimming purposes only, maximum 1 packer per strut.

3 Workshop Fitting Kit FK33 recommended for easier bush install (note: one FK33 kit required per workshop).

4 OME665 Lower Shock Mount Stone Guard is **mandatory** fitment to rear shocks to protect against severe stone pepping encountered on loose road surfaces.

5 D38XL will give approximately 12mm extra lift or increase loading capacity at design height by approximately 160kgs.

6 To achieve 20mm lift for bar and winch, OME95PF5 will need to be fitted with 3080 coil.

7 Volkswagen Service Manual quotes that driveshaft bolts are a one use only. It is recommended to replace bolts. Replacement bolts Volkswagen Part Number **N90991102** are to be sourced separately.

8 To ensure correct 90012 and 90013 strut fitment please refer to fitting instruction part number 3787896 Amarok Strut Fitting Guide.

9 Refer to **Leaf Spring Service Parts** section for Centre Bolt selection.

10 Does not suit OE coil.

Fitting Time: Due to the complexity of installation allow 5 hours for complete install.

SUSPENSION BUSH KIT SELECTION

MODEL	YEAR	LOC'N	DESCRIPTION	OME P/NO.	KITS REQ	BUSHES IN KITS	DIAGRAM #	NOTE
DAIHATSU								
F Series All Models	5/93 on	F	Sway bar - link lower	¹ OMESB2360	2			
		R	Sway bar - link upper	¹ OMESB2360	3	4	7	
Feroza All Models	10/88 on	F	Sway bar - link inner/outer	¹ OMESB2360	10	4	7	
Rocky All Models	4/84 to 93	F	Sway bar - link eye	OMESB0052	15	4	7	
					16	4	7	
FORD								
Courier 1 Tonne All Models	85 to 2005	F	Sway bar - link	OMESB2361	1	4	2	
		R	Spring bush	OMESB82	59	6	4	
Maverick SWB & Wagon Models	8/87 to 9/93	F	Caster Kit	OMECA77B	61	4	8	
			Coil Packer - 5mm	OMEGQPF05	82		8	
			Coil Packer - 10mm	OMEGQPF10	##		8	
			Control arm - to diff front/centre	OMESB0055	##	8	8	
			Control arm - to chassis	OMESB0056	##	4	8	
			Panhard rod	OMESB0054	##	4	8	
			Sway bar - D mount (15mm)	OMESB2365	##	2	8	
			Sway bar - link	OMESB2379	##	8	8	
		R	Coil Packer - 5mm	OMEGQPR05	##		9	
			Coil Packer - 10mm	OMEGQPR10	##		9	
			Control arm - upper	OMESB0062	##	8	9	
			Control arm - lower	OMESB0061	##	8	9	
			Panhard rod	OMESB0054	##	4	9	
			Sway bar - link	OMESB2379	##	8	9	
Maverick Single Cab Models Leaf Spring			Spring & shackle bush kit	OMESB64	##	6	4	Suits OME springs only
Ranger USA Model Only		R	Spring bush	OMESB117	##	6	4	Suits OE shackle
		R	Spring bush	OMESB118	2	6	4	Suits OME greasable shackle OMEGS20
Ranger (not USA Model)	2022 on	R	Spring bush	OMESB117	2	6	4	Suits OE shackle
		R	Spring bush	OMESB118	2	6	4	Suits OME greasable shackle OMEGS20
Ranger PXIII	MY19 18 to 22	R	Spring bush	OMESB117	2	6	4	Suits OE shackle
		R	Spring bush	OMESB118	2	6	4	Suits OME greasable shackle OMEGS20
Ranger PX	11 to 18	R	Spring bush	OMESB117	2	6	4	Suits OE shackle
		R	Spring bush	OMESB118	2	6	4	Suits OME greasable shackle OMEGS20
GMH / ISUZU								
Drover	2/85 on	F	Spring bush	OMESB19	2	6	4	
		R	Spring bush	OMESB19	2	6	4	Suits OE & OME springs
Jackaroo / Trooper Models								
UBS 16 & 17	8/85 to 91	R	Spring & shackle bush kit	OMESB90	2	6	4	Suits OE & OME springs
Rodeo - Isuzu Pick Up Models								
All Models	81 to 87	R	Spring bush	OMESB80	2	6	4	Suits OE & OME springs
V6 Models Only	88 on	R	Spring bush	OMESB80	2	6	4	Suits OE & OME springs
LADA								
Niva	ALL	F	Coil Packer - 10mm	OMELNF10				
LAND ROVER								
Defender 90, 110 & 130, 110 Long Travel, 130 Long Travel Models	92 on	F	Caster kit	CALR2	1	4	8	Suits 44mm wide control arms
County 110 Model	84 to 92	F	Caster kit	CALR1	1	4	8	Suits 38mm wide control arms
Discovery All Models	89 to 99	F	Caster kit	CALR2	1	4	8	Suits 44mm wide control arms
Range Rover	72 to 86	F	Caster kit	CALR1	1	4	8	Suits 38mm wide control arms
Range Rover	86 to 95	F	Caster kit	CALR2	1	4	8	Suits 44mm wide control arms
Defender 110 Long Travel & BP-51 Long Travel excludes Puma Models		R	Bush Kit Trailing Arm Offset Pins	OMESB0068				16mm (Optional)
		R		OMESB0069				20mm (Optional)

1. When remaining stock of OMESB2360 is exhausted, no further product will be available.

cont.

SUSPENSION BUSH KIT SELECTION

MODEL	YEAR	LOC'N	DESCRIPTION	OME P/NO.	BUSHES IN KITS			NOTE
					KITS REQ	DIAGRAM #		
MAZDA								
B2500 & B2600 (B Series 1 Tonne)	3/87 to 98	F	Sway bar - link	OMESB2361	1	4	7	
	87 to 2006	R	Spring bush	OMESB82	2	6	4	
BT-50	11 to 20	R	Spring bush	OMESB117	2	6	4	Suits OE shackle
		R	Spring bush	OMESB118	2	6	4	Suits OME greasable shackle OMEGS20
MITSUBISHI								
Challenger PA Wagon (Rear Leaf Springs)	98 to 5/00	R	Spring bush	OMESB83	2	6	4	
Pajero								
NG	9/89 to 5/91	F	Sway bar - link inner	OMESB2361	1	4	2	Suits V6 & intercooled diesel models
NA, NB, NC, ND, NE, NF & NG	83 to 5/91	F	Sway bar - link inner/outer	¹ OMESB2360	2	4	2	Suits 4 cyl petrol & diesel models not
All Leaf Spring Models	5/91 on	R	Spring bush	OMESB8	2	6	4	
Triton								
Club Cab Model Only		F	Sway bar - link inner/outer	¹ OMESB2360	2	4	2	
		R	Spring bush	OMESB38	2	6	4	
MK Models	10/96 on	R	Spring & shackle bush kit	OMESB38	2	6	4	
NISSAN								
Navara D23 NP300 All	2015 on	R	Spring bush	OMESB114	2	6		Suits OE shackle
				OMESB115				Suits OME greasable shackle OMEGS24
Navara D21 All	9/85 to 97	F	Sway bar - link	OMESB2379	1	8	1	
		R	Spring & shackle bush kit	OMESB81	2	6	4	
Navara D22 All	2/97 on		Sway bar - link upper	OMESB2379	1	8	1	
		R	Spring & shackle bush kit	OMESB81	2	6	4	Suits models to 8/02
		R	Spring & shackle bush kit	OMESB91	2	6	4	Suits models 10/02 on
Pathfinder All	8/86 to 94	F	Sway bar - link	OMESB2379	1	8	1	
Patrol								
MQ (Round Head Lights)	80 to 8/84	F	Spring (front eye) bush kit	OMESB28	2	2	4	Use with OMESB29/OE springs use OMESB3
MQ (Square Head Lights)	8/84 to 87	F	Spring (front eye) bush kit	OMESB31	2	2	4	Use with OMESB29 suits OME springs
MQ All Models	80 to 87	F	Spring (rear eye) bush kit	OMESB29	2	1	4	
		R	Spring & shackle bush kit	OMESB2	2	4	4	Suits OE & OME springs
			Spring bush	OMESB29	2	1	4	Suits OME springs
Y60, GQ	11/87 to 97	F	Body mount - bumper area	¹ OMESB9090	1	4		Suits wagon & hardtops, no kit
		F	Body mount - cab front	¹ OMESB9091	1	4		Suits all wagon to 11/94 & all hardtop models
		F	Body mount - cab centre	OMESB9092	1	4		Suits all wagon & hardtop models
		F	Body mount - cab front & centre	OMESB9092	2	4		Suits pick up & CC models
		F	Caster kit - Control arm	OMECA77B	1	4	8	
		F	Control arm - to axle	OMESB0055	1	8	8	
		F	Control arm - to chassis	OMESB0056	1	4	8	
		F	Spring - eye front/rear & shackle	OMESB1	2	6	4	Suits leaf spring models
		F	Panhard rod - bush	OMESB0054	1	4	8	
		F	Sway bar - link	OMESB2379	1	8	8	Suits coil spring models
		F	Coil Packer - 5mm	OMEGQPF05				
		F	Coil Packer - 10mm	OMEGQPF10				
		R	Body mount - cab rear to axle	OMESB9092	2	4		Suits all wagon models
		R	Body mount - cab rear to axle	OMESB9092	1	4		Suits all hardtop models
		R	Panhard rod - bush	OMESB0054	1	4	9	Not suitable before
		R	Spring - eye front/rear & shackle	OMESB64	2	6	4	Leaf spring models
		R	Sway bar - link	OMESB2379	1	8	9	Suits CC models with coil suspension

1. When remaining stock of OMESB2360, OMESB9090 and OMESB9091 is exhausted, no further product will be available.

cont.

SUSPENSION BUSH KIT SELECTION

MODEL	YEAR	LOC'N	DESCRIPTION	OME P/NO.	KITS REQ	BUSHES IN KITS	DIAGRAM #	NOTES
NISSAN (Continued)								
Patrol - cont.								
Y60, GQ - (cont.)	11/87 to 97	R	Control arm - lower	OMESB0061	1	8	9	
		R	Control arm - upper	OMESB0062	1	8	9	
		R	Coil Packer - 5mm	OMEGQPR05				
		R	Coil Packer - 10mm	OMEGQPR10				
Y61, GU	10/97 on	F	Body mount - bumper area	¹ OMESB9090	1	4		Suits wagon & hardtop, no kit available for CC
		F	Body mount - cab front	¹ OMESB9091	1	4		Suits all wagon & hardtop models
		F	Body mount - cab centre	OMESB9092	1	4		Suits all wagon & hardtop models
		F	Body mount - cab front & centre	OMESB9092	2	4		Suits all CC models
		F	Caster kit - Control arm - to axle	OMECA77B	1	4	8	
		F	Control arm - to axle	OMESB0055	1	8	8	
		F	Control arm - to chassis	OMESB0056	1	4	8	
		F	Panhard rod - bush	OMESB0054	1	4	8	Suits CC all models & wagon to 02/00
		F	Sway bar - link	OMESB2379	1	8	8	Suits coil spring models to 2001
		F	Sway bar - mount 15mm	OMESB2365	1	2	8	Does not suit ZD30
		R	Body mount - cab centre to axle	OMESB9092	2	4		Suits all wagon models
			Body mount - cab centre to axle	OMESB9092	1	4		Suits all hardtop models
		R	Panhard rod - bush	OMESB0054	1	4	9	
		R	Trailing arm - lower	OMESB0061	1	8	9	
		R	Sway bar - link	OMESB2379	1	8	9	Suits CC models with coil suspension.
		R	Trailing arm - upper	OMESB0062	1	8	9	
		R	Coil Packer - 5mm	OMEGQPR05				
			Coil Packer - 10mm	OMEGQPR10				
SUZUKI								
Grand Vitara	To 2005	F	Coil Packer - 10mm	OMESJR10				
Jimny SN413	To 2017	R	Coil Packer - 10mm	OMESJR10				
LJ50	74 to 6/78	F	Spring Bush	OMESB25	2	4		Suits OE & OME springs
	74 to 6/78	R	Spring Bush	OMESB25	2	4		Suits OE & OME springs
LJ80	7/78 to 12/81	F	Spring Bush	OMESB19	2	4		Suits OE & OME springs
		R	Spring Bush	OMESB19	2	4		Suits OE & OME springs
Sierra SJ410 & SJ413	7/81 to 95	F	Spring Bush	OMESB19	2	4		Suits OE & OME springs
		R	Spring Bush	OMESB19	2	4		Suits OE & OME springs
TOYOTA								
4 Runner Leaf Spring Front & Rear								
4 Runner (Surf) LN60, YN60	7/84 to 10/85	F	Spring - bush kit	OMESB5	2	6	4	Suits OE & OME springs
		R	Spring - bush kit	OMESB6	2	6	4	Suits OE & OME springs
4 Runner IFS Front Leaf Spring Rear								
4 Runner (Surf) LN61, YN63	11/85 to 9/89	R	Spring - bush kit	OMESB6	2	6	4	Suits OE & OME springs
HiLux IFS Front & Coil Spring Rear								
4 Runner (Surf) LN130, RN130, VZN130, YN130	10/89 to 6/96	F	Sway bar - mount 25mm	OMESB0049	1	2	12	
		R	Sway bar - link	OMESB2915	1	8	7	Suits LN130, RN130 models
		R	Sway bar - link	OMESB3010	1	4	7	Suits VZN130, YN130 models
HiLux 4WD Leaf Spring Front & Rear								
HiLux (Surf) LN36, 46 RN36, 46	4/79 to 10/83	F	Spring - bush kit	OMESB5	2	6	4	Suits OE & OME springs
		F	Sway bar - link	OMESB2915	1	8	4	
		R	Spring - bush kit	OMESB6	2	6	4	Suits OE & OME springs
HiLux (Surf) LN65, YN 65, 67	11/83 to 9/88	F	Spring - bush kit	OMESB5	2	6	4	Suits OE & OME springs
		R	Spring - bush kit	OMESB6	2	6	4	Suits OE & OME springs

1. When remaining stock of OMESB9090 and OMESB9091 is exhausted, no further product will be available.

cont.

SUSPENSION BUSH KIT SELECTION

MODEL	YEAR	LOC'N	DESCRIPTION	OME P/NO.	KITS REQ	BUSHES IN KITS	DIAGRAM #	NOTES
TOYOTA (continued)								
HiLux 4WD Leaf Spring Front & Rear - (cont.)								
HiLux (Surf) RN105, LN106	10/88 to 11/97	F	Spring - bush kit	OMESB5	2	6	4	Suits OE & OME springs
		F	Sway bar - mount 25mm	OMESB0049	1	2	4	
		R	Spring - spring bush	OMESB6	2	6	4	Suits OE & OME springs
HiLux 4WD IFS Front & Leaf Spring Rear								
HiLux (Surf) LN107, 111, RN106, 110,	10/88 to 12/97	F	Sway bar - mount 25mm	OMESB0049	1	2	1	
		R	Spring - bush kit	OMESB43	2	6	4	Suits OME springs only
LN167, 172, RZN169, 174	11/97 on	F	Sway bar - link	OMESB2915	1	8	1	
		F	Sway bar - mount 25mm	OMESB0049	1	2	1	
		R	Spring - bush kit	OMESB43	2	6	4	Suits OME springs only
KZN165	12/99 on	F	Sway bar - link	OMESB3010	1	4	1	
		F	Sway bar - mount 25mm	OMESB0049	1	2	1	
		R	Spring - bush kit	OMESB43	2	6	4	Suits OME springs only
LandCruiser 40 Series								
BJ40, 42, FJ40, 45, JH45, 47	69 to 12/84	F	Spring - bush kit-to suit 15mm ID	OMESB30	2	6	4	Suits 35mm spring eye
		F	Spring - bush kit-to suit 18mm ID	OMESB1	2	6	4	Suits 35mm spring eye
		R	Spring - bush kit-to suit 15mm ID	OMESB30	2	6	4	Suits 35mm spring eye
		R	Spring - bush kit-to suit 18mm ID	OMESB79	2	6	4	Suits 35mm spring eye & 30mm hanger bracket
		R	Spring - bush kit-to suit 18mm ID	OMESB1	2	6	4	Suits 35mm spring eye
LandCruiser 60 Series								
FJ60, 62, HJ60, 62	11/80 to 8/87	F	Spring - bush kit	OMESB1	2	6	4	
		F	Sway bar - link	OMESB2915	1	8	4	
		R	Spring - bush kit	OMESB1	2	6	4	Suits OE & OME springs
		R	Sway bar - mount 23mm	OMESB2327	1	2	4	
FJ62, HJ60, 61	8/87 to 12/91	F	Spring - bush kit	OMESB1	2	6	4	Suits OE & OME springs
		F	Sway bar - link	OMESB2915	1	8	4	
		F	Sway bar - mount 23mm	OMESB2327	1	2	4	Suits models to 1/90
		R	Spring - bush kit	OMESB1	2	6	4	Suits OE & OME springs
		R	Sway bar - mount 23mm	OMESB2327	1	2	4	
LandCruiser 70 Series								
Bundera (Prado NZ) LJ70, RJ70	1/85 to 12/91	F	Panhard rod - bush	¹ OMESB8133	1	4	10	Suits models to 8/87
		F	Sway bar - link	OMESB2361	2	8	10	
		F	Sway bar - mount 23mm	OMESB2327	1	2	10	Suits models 8/87 -
		F	Sway bar - mount 25mm	OMESB0049	1	2	10	
BJ70, 73, 74	1/85 to 3/90	F	Spring - bush kit	OMESB1	2	6	4	Suit OE & OME springs
		F	Sway bar - link	OMESB2361	2	8	4	
		F	Sway bar - mount 23mm	OMESB2327	1	2	4	Suits models to 5/86
		F	Sway bar - mount 23mm	¹ OMESB0063	1	2	4	Suits models 6/86 on
		R	Spring - bush kit	OMESB1	2	6	4	Suits OE & OME springs
HJ75	1/85 to 3/90	F	Spring - bush kit	OMESB1	2	6	4	Suits OE & OME springs
		F	Sway bar - link	OMESB2361	2	8	4	
		F	Sway bar - mount 23mm	OMESB2327	1	2	4	Suits models to 5/86
		F	Sway bar - mount 23mm	¹ OMESB0063	1	2	4	Suits models 6/86 on
		R	Spring - bush kit	OMESB16	2	6	4	
FJ70, 73, 75	1/85 to 10/92	F	Spring - bush kit	OMESB1	2	6	4	Suits OE & OME springs
		F	Sway bar - link	OMESB2361	2	8	4	
		F	Sway bar - mount 23mm	OMESB2327	1	2	4	Suits models to 5/86
		F	Sway bar - mount 23mm	¹ OMESB0063	1	2	4	Suits models 6/86 on
		F	Sway bar - mount 25mm	OMESB0049	1	2	4	Suits FJ75 models to
		R	Spring - bush kit	OMESB16	2	6	4	Suits FJ70, 73 models
		R	Spring - bush kit	OMESB1	2	6	4	
		R	Sway bar - mount 25mm	OMESB0095	1	2	4	Suits bracket height = 38mm
FZJ70, 75, HZJ70, 73, 75	1/88 to 11/99	F	Spring - bush kit	OMESB1	2	6	4	Suits OE & OME springs

1. When remaining stock of OMESB0063 and OMESB8133 is exhausted, no further product will be available.

cont.

SUSPENSION BUSH KIT SELECTION

MODEL	YEAR	LOC'N	DESCRIPTION	OME P/NO.	KITS REQ	BUSHES IN KITS	DIAGRAM #	NOTES
TOYOTA (continued)								
LandCruiser 70 Series - cont.								
FZ170, 75, HZ170, 73, 75 - (cont.)	1/88 to 11/99	F	Sway bar - link	OMESB2361	2	8	4	
		F	Sway bar - mount 23mm	¹ OMESB0063	1	2	4	Suits HZ175 models to 4/91
		F	Sway bar - mount 25mm	OMESB0049	1	2	4	Suits HZ175 models to 4/91
		F	Sway bar - mount 25mm	OMESB0095	1	2	4	Suits 4/91 on bracket height = 38mm
		R	Spring - bush kit	OMESB16	2	6	4	Suits FJ75 models
		R	Spring - bush kit	OMESB1	2	6	4	Suits HZ170 & 73
		R	Sway bar - mount 25mm	OMESB0095	1	2	4	Suits 4/91 on bracket height = 38mm
PZ170, 73	3/90 to 2/91	F	Spring - bush kit	OMESB1	2	6	4	Suits OE & OME springs
		F	Sway bar - link	OMESB2361	1	8	4	
		R	Spring - bush kit	OMESB1	2	6	4	Suits OE & OME springs
FZ178, 79, HDJ78, 79, HZ178, 79	8/99 on	F	Caster kit	OMECA77B	1	4	10	Caster align offset 3 degree
		F	Control arm - to chassis	OMESB0050	1	4	10	
		F	Sway bar - link outer	OMESB2413	1	2	10	Contains new bolts, nuts & crush tubes
		F	Sway bar - mount 31mm	OMESB2414	1	2	10	
		F	Panhard rod - bush	OMESB0046	1	4	10	
		R	Sway bar - link inner	OMESB3010	1	4	8	
		R	Sway bar - link outer lower	OMESB0052	1	4	4	
		R	Sway bar - link outer upper	OMESB3010	1	4	4	
			Sway bar - mount 25mm	OMESB0095	1	2	4	Suits bracket height = 38mm
			Spring - bush kit	OMESB86	2	6	4	Suits FZ1 / HDJ / HZ178 models with OME
			Spring - bush kit	OMESB84	2	6	4	Suits FZ1 / HDJ / HZ179 models with OME
			Spring - bush kit	OMESB85	2	6	4	Suits all models with OME springs & greasable shackles
LandCruiser 80 Series								
FJ80, FZ180, HDJ80, HZ180	1/90 to 2/98	F	Caster kit	OMECA77B	1	4	10	Caster align offset 3 degree
		F	Control arm - to chassis only	OMESB0050	1	4	10	
		F	Panhard rod - bush	OMESB0046	1	4	10	
		F	Control arm - complete kit	OMESB0045	2	6	10	
		F	Sway bar - link upper	OMESB0051	1	4	10	
		F	Sway bar - link lower	OMESB0044	1	4	10	
		F	Sway bar - mount 24mm	¹ OMESB0063	1	2	10	Suits bracket height = 35mm
		F	Sway bar - mount 26mm	¹ OMESB0094	1	2	10	Suits bracket height = 35mm
		F	Sway bar - mount 26mm	¹ OMESB0091	1	2	10	Suits bracket height = 38mm
		F	Sway bar - mount 29mm	OMESB0092	1	2	10	Suits bracket height = 38mm
		F	Coil Packer - 5mm	OME80PF05			10	
		F	Coil Packer - 10mm	OME80PF10			10	
		R	Panhard rod - bush	OMESB0053	1	4	8	
		R	Sway bar - link lower	OMESB0052	1	4	8	
		R	Sway bar - link upper	OMESB3010	1	4	8	

1. When remaining stock of OMESB0063, OMESB0091 and OMESB0094 is exhausted, no further product will be available.

cont.

SUSPENSION BUSH KIT SELECTION

MODEL	YEAR	LOC'N	DESCRIPTION	OME P/NO.	KITS REQ	BUSHES IN KITS	DIAGRAM #	NOTES
TOYOTA (continued)								
LandCruiser 80 Series - (cont.)								
FJ80, FZJ80, HDJ80, HZJ80 - (cont.)	1/90 to 2/98	R	Sway bar - mount 25mm	OMESB0049	1	2	8	Suits bracket height = 35mm
		R	Sway bar - mount 25mm	OMESB0095	1	2	8	Suits large bracket height = 38mm
		R	Control arm - lower	OMESB0047	1	8	8	
		R	Control arm - upper	OMESB0048	1	8	8	
LandCruiser 100 Series								
FZJ105, HZJ105 Solid Axle	3/98 on	F	Caster kit	OMECA77B	1	4	10	Caster align offset 3 degree
		F	Control arm - complete kit	OMESB0045	2	6	10	STD replacement
		F	Control arm - to chassis only	OMESB0050	1	4	10	
		F	Panhard rod - bush	OMESB0046	1	4	10	
		F	Sway bar - link lower	OMESB0044	1	2	10	
		F	Coil Packer - 5mm	OME80PF05				
		F	Coil Packer - 10mm	OME80PF10				
		F	Sway bar - mount 29mm	OMESB0092	1	2	10	Suits large bracket height = 38mm
		R	Sway bar - link upper	OMESB3010	1	4	8	
		R	Sway bar - link lower	OMESB0052	1	4	8	
		R	Panhard rod - bush	OMESB0053	1	4	9	
		R	Sway bar - mount 25mm	OMESB0095	1	2	8	Suits bracket height = 38mm
		R	Control arm - lower	OMESB0047	1	8	8	
		R	Control arm - upper	OMESB0048	1	8	8	
		R	Coil Packer - 5mm	OME80PR05				
		R	Coil Packer - 10mm	OME80PR10				
LandCruiser Lexus								
HDJ100, UZJ100 (Lexus) IFS	3/98 on	F	Sway bar - link upper	OMESB2361	1	4	7	
		R	Sway bar - link	OMESB2915	1	8	7	
Tacoma								
Tacoma	2016 on	R	Spring - bush kit	OMESB108	2	4	4	
Tacoma V6	2005 to 2015	R	Spring - bush kit	OMESB108	2	4	4	
Tacoma V6 & 4 Cylinder	1998 to 2004	R	Spring bush	OMESB88	2	4	4	Suits OMEGS12 greasable shackles
		R	Spring bush	OMESB89	2	4	4	Suits original shackles only
		R	Spring bush	OMESB121	2	6	4	Suits OE & OMEGS12 greasable shackles
Tundra								
Tundra	2007 on	R	Spring - bush kit	OMESB106	2	6	4	Suits OMEGS122 greasable shackles

cont.

DIAGRAM REFERENCE FOR SUSPENSION BUSH KITS

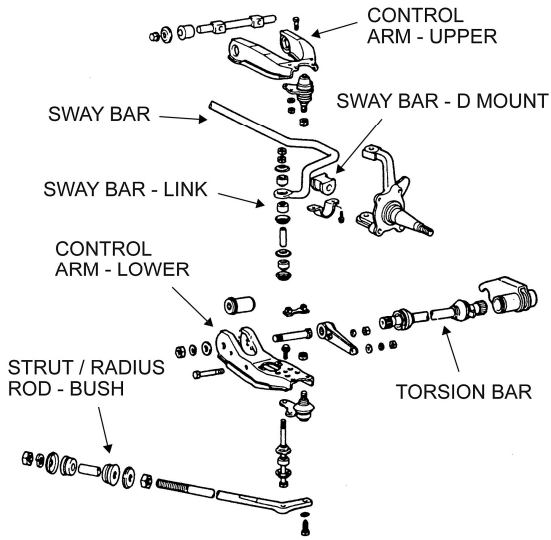

Diagram 1.

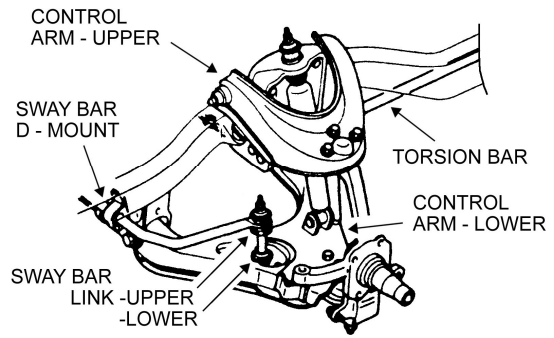

Diagram 2.

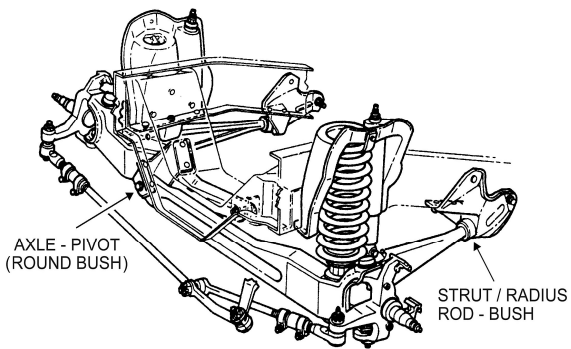

Diagram 3.

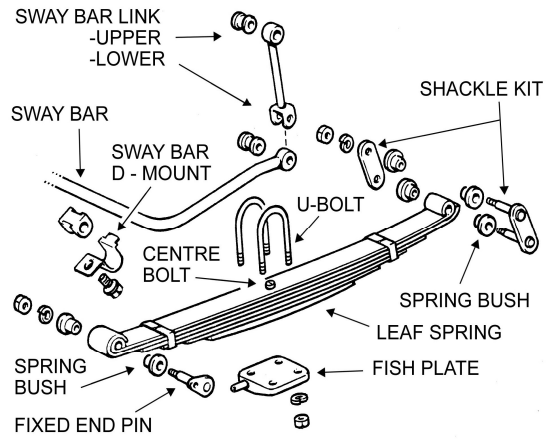

Diagram 4.

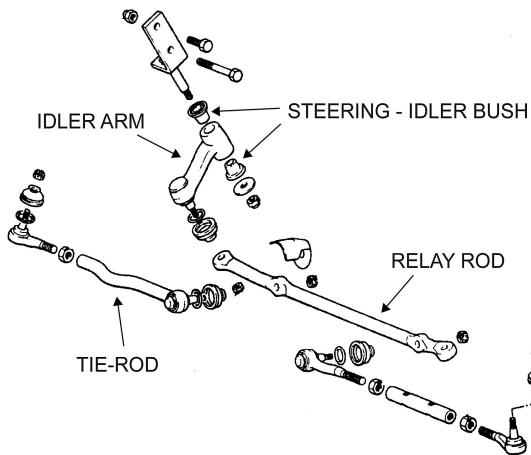

Diagram 5.

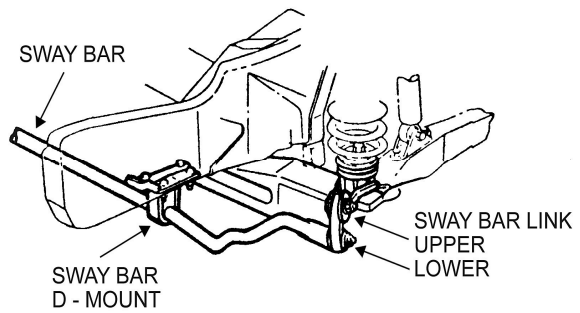

Diagram 6.

DIAGRAM REFERENCE FOR SUSPENSION BUSH KITS

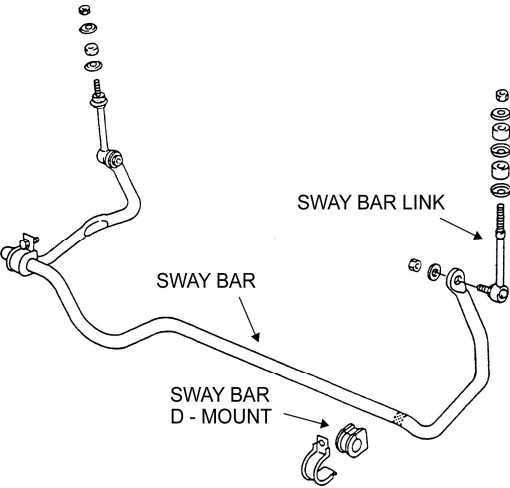

Diagram 7.

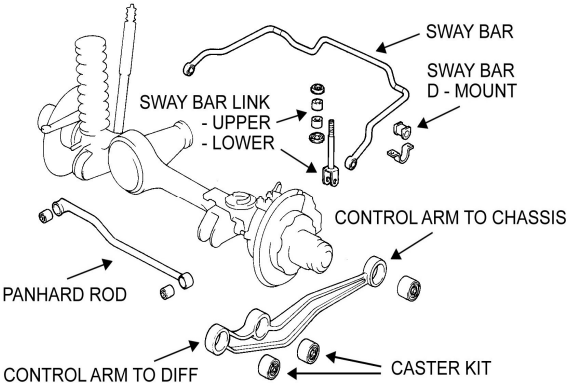

Diagram 8.

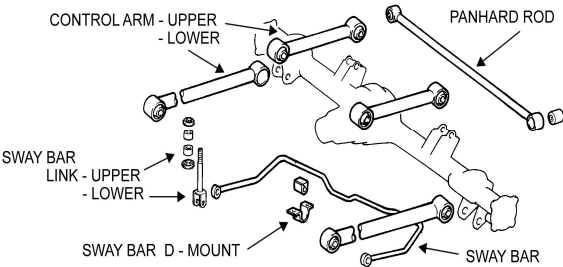

Diagram 9.

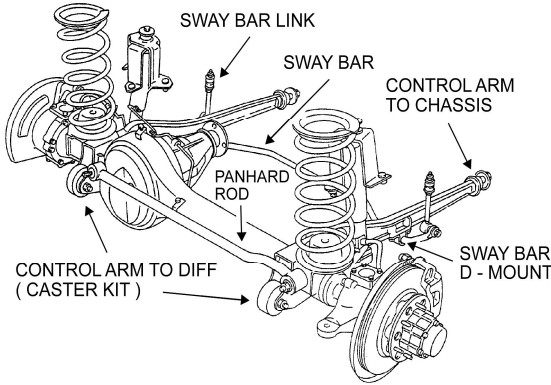

Diagram 10.

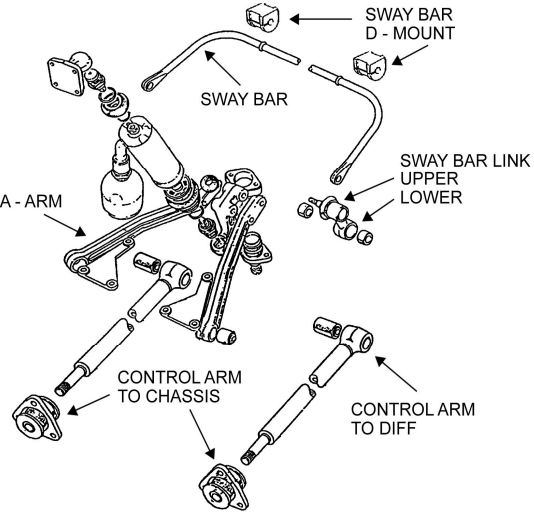

Diagram 11.

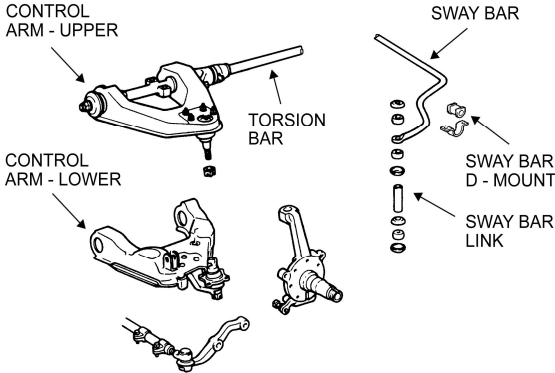

Diagram 12.

APPLICATIONS - SPECIFICATIONS - BUSH KITS

NUMERICAL SPRING & SHOCK / STRUT BUSH

Kit No.	Component Description	Qty	To Fit
OMESB1	spring bush PT260	6	Toyota 35mm spring eye, 18mm pin OE & OME Series F/H/B, J/ZJ: 75, 74, 73, 70, 60, 47, 45, 42, 40 Nissan GQ Patrol leaf spring models OME only
OMESB2	spring bush PT280 spring bush PT281	2 2	Nissan MQ Patrol all models - rear OE spring
OMESB3	spring bush PT282	2	
¹ OMESB4	spring bush PT230 spring bush PT229	4 2	LandCruiser 40 74/5 Series - OBSOLETE
OMESB5	spring bush PT240 spring bush PT231	2 4	Toyota HiLux & 4Runner all leaf spring models pre 1997 (not IFS front)
OMESB6	spring bush PT231	6	Toyota HiLux & 4Runner all leaf spring models pre 1997 (not IFS front, SR5, extra cab rear). 4Runner IFS rear leaf spring models (not pre 1997)
¹ OMESB7	OBSOLETE	6	Toyota FJ55 all models front & rear, 45 Series rear only OE springs 30mm eye
OMESB8	spring bush PT290 spring bush PT291 spring bush PT292	2 2 2	Mitsubishi Pajero to 1991 rear leaf spring models & L200 models
¹ OMEB9	shock bush SP1178 / 19	4	Small eye bush with 19mm bore - OBSOLETE
OMEB10	shock bush SP056 (cotton reel type)	2	Small eye shock mount
OMEB11	shock bush OME066 / 16	4	Converts large eye 19mm bore to a 16mm bore
¹ OMEB12	shock bush kit	4	Pin 12 x 60 replacement bush - OBSOLETE
OMEB13	shock bush SP091	4	Pin 10 x 60 replacement bush
OMEB14	shock bush OME1178 / 16	4	Small eye with 16mm bore
OMEB15	shock bush OME066 / 19	4	Large eye with 19mm bore
OMESB16	spring bush PT270	6	40mm spring eye for Toyota 75 series rear springs
OMEB17	shock bush OME066 / 22 sleeve B17S 22 x 16 x 33	2 2	Large eye tapered bush with sleeve
¹ OMEB18	OBSOLETE	2	Converts small eye bush to suit 19mm bore with sleeves
OMESB19	spring bush PT301 spring bush PT302 sleeve B19S 16 x 13 x 65	2 4 1	Suzuki Sierra all models except LJ50 front & rear springs
OMESB20	spring bush PT229	6	Toyota LandCruiser 40 series 25mm OE spring front & rear. Toyota 45 series OE front spring only 25mm eye.
OMESB25	spring bush PT301 spring bush PT302 spring bush PT303 sleeve 16 x 13 x 65	2 2 2 1	Suzuki LJ50 front & rear
OMEB27	sleeve 16 x 13.2 x 33	2	N41 ¹ & N81 being converted for fitment to CJ Jeep and Cherokee wagon 83 on front bottom mount. Mahindra front & rear bottom mount. 81 on F100 & Bronco.
OMESB28	spring bush PT284	2	Nissan MQ Patrol early model (round headlights) - front spring, front eye (to be fitted with OMESB29)
OMESB29	spring bush PT285 & sleeve	1	Nissan MQ Patrol all models - front spring, rear eye (to be fitted with OMESB28)
OMESB30	spring bush PT261 spring bush PT229	4 2	Toyota LandCruiser 45/47 Series front spring with 35mm spring eye and hanger bracket with 15mm pin hole
OMESB31	spring bush PT283	2	Nissan MQ Patrol late model (square headlights) - front spring, front eye (to be fitted with OMESB29)
OMEB36	shock bush OME066 / 19	2	large eye 19mm bore

1. When remaining stock is exhausted no further product will be available.

cont.

APPLICATIONS - SPECIFICATIONS - BUSH KITS

NUMERICAL SPRING & SHOCK / STRUT BUSH

Kit No.	Component Description	Qty	To Fit
OMESB38	spring bush PT292 spring bush PT291 spring bush PT305 sleeve 19 x 14.2 x 81	2 2 2 1	All Triton to 1997 and L200 - rear - suits OME springs only
OMEB40	shock bush OME 066-19MGQ	2	¹ N101, ¹ N22F & N29 Patrol GQ lower mount - rear shock
OMEB42	shock bush 3051Y	8	pin 14 x 70 replacement
OMESB43	spring bush PT304 spring bush PT309 spring bush PT231 sleeve 19 x 14.1 x 68	2 2 2 1	Toyota HiLux IFS extra cab & SR5 dual cab models being fitted with OME18 ¹ series spring. 1997 to 2004 all models, pre 1997 IFS & rear leaf models
OMESB57	spring bush PT306 spring bush PT307 sleeve 19 x 15 x 73	4 2 1	Jeep Wrangler YJ - front & rear to suit OE shackles Jeep Wrangler YJ - front & rear to suit OE shackles
OMESB64	spring bush PT270 spring bush PT260	4 2	Nissan Patrol GQ leaf spring cab chassis OME spring - rear
¹ OMESB75	spring bush LA118 spring bush LA119 sleeve 19 x 14.3 x 91 sleeve 19 x 15 x 70	2 4 1 2	Land Rover Series III 88" & 109" spring & shackle bushes OE replacement - front OBSOLETE
¹ OMESB76	spring bush kit	6 3	Land Rover series III 88" & 109" spring & shackle bushes OE replacement - rear - OBSOLETE
¹ OMEB77	shock bush kit	4	Land Rover Series III 88" & 109" lower shock bush - rear - OBSOLETE
¹ OMEB78	steering damper bush kit	4	Pin 10 x 60mm steering stabiliser mount - OBSOLETE
OMESB79	spring bush PT308 spring bush PT231A	4 2	LandCruiser F/HJ45, 47 LWB models - OME spring
OMESB80	spring bush PT304 spring bush PT231 sleeve 19 x 14 x 68	2 4 1	Holden / Isuzu Rodeo 1 tonne rear spring to suit OE & OME springs
OMESB81	spring bush PT310 spring bush PT311 sleeve 22 x 18 x 70	4 2 1	Nissan Navara 1 tonne rear spring to suit OE & OME springs
OMESB82	spring bush PT281 spring bush PT314 spring bush PT315 sleeve 22 x 17 x 68	2 2 2 1	Ford Courier 1 Tonne 4x4 1985 To 2005 All Models Mazda B Series 1 Tonne 1987 To 2006 rear spring OME only
OMESB83	spring bush PT291 spring bush PT292 spring bush PT316 sleeve 22 x 16 x 80	2 2 2 1	Mitsubishi Challenger 1998 to 2000 PA LWB leaf spring rear / Montero rear spring to suit OME19 ¹ only
OMESB84	spring bush PT317 spring bush PT318 sleeve 20 x 14 x 86	2 4 2	Toyota LandCruiser 79 Series cab chassis & utility model only suit OME springs only
OMESB85	spring bush PT270 spring bush PT317	4 2	Toyota LandCruiser 78 & 79 Series must be used with OME springs & greasable shackle kit only. Toyota LandCruiser 70 Series Dual Cab.
OMESB86	spring bush PT327 spring bush PT318 spring bush PT319 sleeve 20 x 14 x 86	2 2 2 1	Toyota LandCruiser 76 & 78 Series Rear suit OME springs with OE shackles.
OMESB87	spring bush PT307 spring bush PT320 spring bush PT321 sleeve 19 x 15 x 73	2 2 2 1	Jeep YJ Wrangler front and rear Use only with greasable shackle OMEGS11
OMESB88	spring bush PT322 spring bush PT323	2 2	Toyota Tacoma 98 to 04 rear shackle bushes only Use with

1. When remaining stock is exhausted no further product will be available.

cont.

APPLICATIONS - SPECIFICATIONS - BUSH KITS

NUMERICAL SPRING & SHOCK / STRUT BUSH

Kit No.	Component Description	Qty	To Fit
OMESB89	spring bush PT322 spring bush PT323 sleeve 18 x 14 x 69	2 2 1	Toyota Tacoma 1998 to 2004 rear shackle bushes for OEM shackles
OMESB90	spring bush PT231 spring bush PT282	4 2	Holden/Isuzu Jackaroo Trooper 1982 to 1992 rear OME spring
OMESB91	spring bush PT310 spring bush PT311 spring bush PT326 sleeve 22 x 18 x 70	2 2 2 1	Nissan Navara D22 model - rear spring to suit OE & OME springs
OMESB93	spring bush PT260 spring bush PT317	4 2	Toyota LandCruiser HZJ71 & HZJ74
¹ OMESB95	spring bush PT326 spring bush PT331	2 2	Nissan D40 Navara suits OE shackle kit only OBSOLETE
¹ OMESB96	spring bush PT324 spring bush PT325	2 2	Nissan D40 Navara suits OME greasable shackle kit only - OBSOLETE
OMESB97	spring bush PT281 spring bush PT314 spring bush PT333 sleeve 19 x 14 x 72	2 2 2 1	Ford Ranger 06 to 11 / Mazda BT50 06 To 11
OMESB98	spring bush PT328 spring bush PT329 spring bush PT333 sleeve 19 x 14 x 72	2 2 2 1	Toyota HiLux 2005 on to suit OE & OME springs. Holden Colorado 12 on / Isuzu DMAX 12 to 2020 suits OME Greasable Shackle, OMEGS14.
OMESB99	spring bush PT282 spring bush PT326 spring bush PT331 sleeve 18 x 14 x 69	2 2 2 1	Nissan Navara D40 suits original shackle kit only.
OMESB100	spring bush PT282 spring bush PT324 spring bush PT325 sleeve 18 x 14 x 69	2 2 2 1	Nissan Navara D40 suits OME greasable shackle kit: OMEGS15
OMESB101	spring bush PT319 spring bush PT327 spring bush PT347	2 2 2	Toyota LandCruiser 79 Series suits original shackle & pin from 07/2009 on / 70 Series Dual Cab
OMESB102	spring bush PT310 spring bush PT333 spring bush PT336 sleeve 19 x 14 x 72	2 2 2 1	Ford Ranger PX 2011 to 2022 / Mazda BT-50 2011 to 2020 suits OE shackle
OMESB103	spring bush PT335 spring bush PT333 spring bush PT281 sleeve 19 x 14 x 72	2 2 2 1	Ford Ranger PX 2011 to 2022 / Mazda BT-50 2011 to 2020 suits OME greasable shackle kit OMEGS20
OMESB104	bush leaf spring VW-007 bush leaf spring VW-008	1 1	Volkswagen Amarok
OMESB105	spring bush PT324 spring bush PT311 sleeve 22 x 18 x 70	4 2 1	Nissan Navara D22 suits OME greasable shackle
OMESB106	spring bush PT317 spring bush PT282 spring bush PT333 sleeve 19 x 14 x 72	2 2 2 1	Toyota Tundra 2007 on suits OME greasable shackle OMEGS22
OMESB107	spring bush PT333 spring bush PT337 spring bush PT338 sleeve 19 x 14 x 72	2 2 2 1	Holden Colorado12 on / Isuzu DMAX 12 to 2020 suits OE shackle
OMESB108	spring bush PT333 sleeve 19 x 14 x 72	4 2	Toyota Tacoma 2016 On / Tacoma V6 05 to 15 suits OE shackle

1. When remaining stock is exhausted no further product will be available.

cont.

APPLICATIONS - SPECIFICATIONS - BUSH KITS

NUMERICAL SPRING & SHOCK / STRUT BUSH

Kit No.	Component Description	Qty	To Fit
OMESB109	spring bush PT341	4	Ford F250, F350 2011 to 2017 / F250, F350 2008 To 2010
	sleeve 26 x 20 x 89	1	
	sleeve 26 x 16 x 89	1	
OMESB113	spring bush PT345	2	Mitsubishi Triton MR, MQ suits greasable shackle OMEGS23
	spring bush PT291	2	
	spring bush PT344	2	
	sleeve 19 x 14 x 78	1	
OMESB114	spring bush PT326	4	Nissan Navara NP300 2015 on Series 1, 2, 3, 4 & 5 suits OE shackles
	spring bush PT282	2	
	sleeve 18 x 14 x 69	1	
OMESB115	spring bush PT324	4	Nissan Navara NP300 2015 on Series 1, 2, 3, 4 & 5 suits OME greasable shackle
	spring bush PT282	2	
	Sleeve 18 x 14 x 69	1	
OMESB116	spring bush PT333	2	Chevrolet Colorado 2015 on USA model
	spring bush PT346	2	
	sleeve 19 x 14 x 76	1	
	sleeve 22 x 16 x 76	1	
OMESB117	spring bush PT310	2	Ranger 2022 on (not USA model) Ranger PXIII MY19 2018 to 2022 / Ranger PX 2011 to 2018 / BT-50 2011 to 2020 suits OE shackles
	spring bush PT346	2	
	spring bush PT336	2	
	sleeve 22 x 14 x 73	1	
OMESB118	spring bush PT281	2	Ranger USA model / Ranger 2022 on / Ranger PXIII MY19 2018 to 2022 / Ranger PX 2011 to 2018 / BT-50 2011 to 2020 suits OME greasable shackle
	spring bush PT335	2	
	spring bush PT346	2	
	sleeve 22 x 14 x 73	1	
OMESB119	spring bush PT333	2	Isuzu DMAX 2021 on / Mazda BT-50 2021 on suits greasable shackle OMEGS26
	spring bush PT328	2	
	OME spring bush PT354	2	
	sleeve 19 x 14 x 73	1	
OMESB120	spring bush PT333	2	Isuzu DMAX 2021 on / Mazda BT-50 2021 on suits OE shackle
	spring bush PT337	2	
	OME spring bush PT353	2	
	sleeve 19 x 14 x 73	1	
OMESB121	spring bush PT322	2	Toyota Tacoma V6 & 4 cylinder 1998 To 2004
	spring bush PT282	4	
	sleeve 18 x14 x 69	2	
OME3101	upper bush 3101A	1	Mitsubishi Pajero 2000 to 2006 all SWB & LWB Models
	lower bush 3010B	1	
	crush tube F0043	1	
OME3121	upper bush 67257	1	Mitsubishi Pajero Sport 2015 on / Triton ML / Triton MN / Challenger 2010 to 2015
	lower bush 67258	1	
	washer 5w327	2	
	F1528 16 x 10.2 x 36	1	
OME3125	upper bush 68509A-2	1	Toyota Landcruiser 200 Series
	lower bush 68510-2	1	
	washer 5w327	2	
OME3133	upper bush 68351	1	Toyota HiLux 05 on / Prado 150 not Kakadu or SWB 09 on coil sprung / Prado 120 / FJ Cruiser / Fortuner / 4 Runner 03 on USA models / Tacoma V6 05 to 15 / Tacoma 16 on
	lower bush 68352	1	
	washer 5w327	2	
OME3134	upper bush 68201	1	Holden Trailblazer 2017 on / Colorado 7 2013 to 2016 /Colorado 2012 on / Isuzu DMAX 2012 on / MU-X 2013 on / Mazda BT-50 2021 on
	lower bush 68202	1	
	washer 5w327	2	
OME3135	upper bush 68168	1	Ford Ranger PX 2011 to 2018 / Everest 2015 to 2018 Mazda BT-50 2011 to 2020
	lower bush 68169	1	
	washer 5w327	2	
	crush tube F1281	1	

cont.

NUMERICAL SPRING & SHOCK / STRUT BUSH

Kit No.	Component Description	Qty	To Fit
OME3139	upper bush 67496	1	Nissan Navara D23 NP300 15 to 18 Series 1, 2 & 3 / D40 & USA Frontier 05 on / Pathfinder R51 05 to 2014 not USA model / Xterra 2005 on / Suzuki Equator USA only
	lower bush 67496	1	
	washer 5w327	2	
	crush tube F0055	1	

SPECIFICATIONS - BUSH KITS

OLD MAN EMU POLYURETHANE SPRING BUSH DIMENSIONS

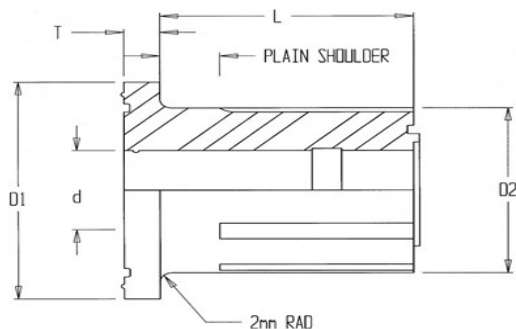

Dimensions					
Part No.	D1	D2	d	T	L
PT229	38.0	25.0	15.0	5.0	33.0
PT230	32.0	25.0	15.0	3.15	33.0
PT231	40.0	30.0	18.0	4.50	28.0
PT240	40.0	30.0	18.0	4.75	45.0
PT260	49.0	35.0	18.0	6.30	33.0
PT261	45.0	35.0	15.0	4.0	33.0
PT270	50.0	40.0	18.0	6.30	33.0
PT280	44.0	32.70	18.0	5.50	40.0
PT281	40.0	32.70	18.0	4.75	28.0
PT282	54.0	40.0	18.0	4.75	28.0
PT283	44.0	32.70	18.0	6.09	28.0
PT285	None	32.90	16.20	None	60.0
PT290	45.0	31.50	18.0	4.62	33.0
PT291	40.0	28.0	16.0	5.25	43.0
PT292	40.0	27.50	16.0	5.25	33.0
PT301	50.0	40.0	16.0	7.90	23.0
PT302	40.0	30.0	13.0	4.20	23.0
PT304	52.0	40.0	19.0	4.75	28.0
PT305	43.0	31.5	19.0	5.80	33.0
PT306	44.0	31.60	18.0	6.0	28.0
PT307	50.0	37.6	19.0	6.0	28.0
PT309	40.0	30.0	18.0	4.20	38.0
PT310	42.0	32.70	20.0	4.50	28.0
PT311	52.0	40.0	22.2	5.25	28.0
PT314	44.0	32.0	18.0	5.3	38.0
PT315	40.0	32.7	22.2	4.20	28.0
PT316	43.0	31.5	22.2	5.25	33.0
PT317	53.0	40.0	18.0	6.30	41.0
PT318	53.0	40.0	20.0	8.40	33.0
PT319	53.0	40.0	18.0	10.50	33.0
PT320	44.0	31.50	18.0	6.85	28.0
PT321	44.0	32.0	18.0	5.25	31.0
PT322	41.0	30.0	18.0	4.20	42.0
PT323	41.0	30.0	18.0	4.75	28.0
PT324	40.0	32.70	19.0	4.20	28.0
PT325	40.0	33.0	19.0	4.20	42.0
PT326	41.0	32.70	20.0	4.20	28.0
PT327	53.0	40.0	18.0	8.40	41.0
PT328	40.0	30.0	19.0	4.20	28.0
PT329	42.0	30.0	19.0	4.20	42.0
¹ PT330	54.0	39.60	19.0	6.30	28.0
PT331	48.0	33.0	20.0	4.20	42.0
PT333	56.0	40.0	19.0	6.85	28.0
PT335	45.0	32.0	18.0	4.75	47.0

1. When remaining stock is exhausted no further product will be available.

cont.

SPECIFICATIONS - BUSH KITS

OLD MAN EMU POLYURETHANE SPRING BUSH DIMENSIONS

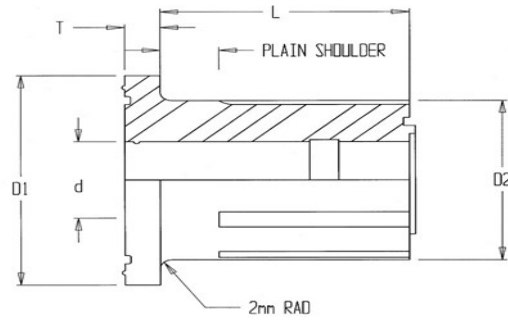

Dimensions					
Part No.	D1	D2	d	T	L
PT336	42.0	32.0	20.0	4.50	47.0
PT337	39.0	30.0	18.0	4.20	28.0
PT338	39.0	30.0	18.0	4.50	42.0
PT341	50.0	42.0	26.0	6.75	36.0
PT342	50.0	40.0	21.20	5.25	28.0
PT343	50.0	42.0	21.20	5.25	28.0
PT344	52.0	40.0	19.0	9.50	28.0
PT345	41.0	27.0	16.0	5.25	28.0
PT346	65.0	50.0	22.20	6.85	28.0
PT347	53.0	40.0	18.0	9.20	33.0
PT353	39.0	30.0	19.0	3.70	50.5
PT354	40.0	30.0	20.0	4.20	50.5

SPECIFICATIONS - FITTING KITS

SUSPENSION FITTING KITS

Part No.	Contains	Vehicle	Position	Refer to:
FK01	16 x Flat Washer	Toyota LC 60 Series	Front	Manual Sec. 4 GFI - Front suspension installation
FK03	2 x Saddle Correction Plate	HiLux Pre 1997 Petrol	Front	Manual Sec. 4 GFI - Front suspension installation
FK0411	4 x Retainer Spacer 11mm	Toyota LC 60 Series	Rear	Manual Sec. 4 GFI
FK0418	4 x Retainer Spacer 18mm	Toyota LC 60 Series	Rear	Manual Sec. 4 GFI
FK0422	4 x Retainer Spacer 22mm	Toyota LC 60 Series	Rear	Manual Sec. 4 GFI - Rear suspension installation
FK047	4 x Retainer Spacer 7mm	Toyota LC 60 Series	Rear	Manual Sec. 4 GFI - Rear suspension installation
FK06	2 x Stabiliser Bar Packer 3mm	Drover / Sierra (SJ413)	Front	Manual Sec. 4 GFI - Front suspension installation
FK08	2 x Anti-Inversion Plate	Toyota LC 60, 75 Series All 40 & 70 Series, Nissan GQ Patrol, Ford Maverick ute & c/c	Front & Rear	Manual Sec. 8 Technical - Shackle Modification
FK09	2 x Anti-Inversion Plate	Toyota HiLux All Models	Rear	Manual Sec. 8 Technical - Shackle Modification
FK10	2 x Short Gussett Plate 2 x Long Gussett Plate	HiLux Pre 97 Petrol & Diesel Used Off Road	Front	Manual Sec. 8 Technical - HiLux Front Springs
FK13	2 x Anti-Inversion Side Plate	Toyota HiLux All Models	Rear	Manual Sec. 4 GFI
FK14	2 x Anti-Inversion Plate	Isuzu 1 Tonne P/Up	Rear	Fitting instructions supplied with kit
FK15	2 x Anti-Inversion Side Plate	HiLux / Tiger 97 to 04	Rear	Fitting instructions supplied with kit
FK16	2 x 20mm Bump Stop Spacer	Jeep Wrangler TJ	Rear	Fitting instructions supplied with kit
FK18	2 x Bracket 3 x Bolt 3 x Washer 3 x Nut	Nissan GU Patrol	Rear Sway Bar	Fitting instructions supplied with kit
FK19	4 x Spacer Plate 4 x 35mm Bolt 4 x Spring Washer	LandCruiser 70S DC, 76S Wagon, 78S & 79S SC Models	Front Sway Bar	Fitting instructions supplied with kit
¹ FK20	6 x Spacer Plate 8 x Bolt M8 x 1.25 x 35mm 8 x Flat Washer	Land Rover Discovery 1999 on Models	Front Cross Member	Fitting instructions supplied with kit
FK21	1 x Bracket 2 x Bolt M8 2 x Flat Washer 2 x Hex Nut	Toyota Tacoma V6 & 4 cylinder 1998 to 2004	Rear Exhaust Bracket	
FK22	2 x Shock Tower Support 2 x Captive Nut 4 x Bolt M10 x 1.5 x 30mm 4 x Flat Washer 4 x Spring Washer	Ford Courier 85 to 05 1 tonne pickup / Ranger PJ 12/06 to 11 / Mazda B Series 87 to 06 / BT-50 12/06 to 11	Front	Fitting instructions
FK23	1 x Strut Adaptor	Toyota RAV 4 1998 to 2000	Front	Fitting instructions
FK24	2 x Bracket 6 x Bolt 11 x Flat Washer 6 x Nut Nyloc	Nissan Y61 Patrol with stabiliser bar release	Rear Sway Bar	Fitting instructions
FK25	2 x Spacer Block 4 x Bolt 4 x Flat Washer 4 x Spring Washer	Nissan Y61 Patrol Oil Pan Kit	Front	Fitting instructions
FK26	2 x Side Plate	Isuzu DMAX & Holden Colorado RC 08 to 11 Holden Rodeo 03 to 11	Rear	Fitting instructions supplied with kit
FK27	2 x Support Bracket	Toyota LandCruiser 100 Series IFS	Torsion Bar Locating Bracket	Fitting instructions supplied with kit
¹ FK28	2 x Spacer 2 x Stud	Suzuki XL7 2001 to 2005	Front	Fitting instructions supplied with kit
FK29	2 x Spacer 2 x Bolt M10 x 1.25 x 35mm 2 x Flat Washer M10 x 25mm 2 x Spring Washer M10 x 1/8	Toyota Fortuner 2015 on Toyota Tacoma 2016 on Toyota Tacoma V6 2005 to 2015	Rear Drive Shaft	Fitting Instructions
FK30	2 x Anti-Inversion Bracket	Triton MK / L200 to 96	Rear	Fitting Instructions
FK31	1 x Bracket 6 x Bolt 4 x Nut x M10 2 x Nut x M10 Caged 3.3 6 x Spring Washer 10 x Flat Washer	Ford F250, F350 1999 to 2004 Dual Cab Models / 2005 to 2008 Crew Cab Models	Rear	Fitting instructions
FK32	1 x 3199908 Bracket 1 x 3199909 Kit 2 x Bolt M8 x 1.25 x 20 2 x Hex Nyloc Nut	Toyota Tundra 2007 on	Front	Fitting instructions

1. When remaining stock is exhausted no further product will be available.

cont.

SPECIFICATIONS - FITTING KITS

SUSPENSION FITTING KITS

Part No.	Contains	Vehicle	Position	Refer to:
FK32 (cont.)	4 x Flat Washer	Toyota Tundra 2007 on	Front	Fitting instructions
FK33	Spring Bush Installation Tool	Volkswagen VK Amarok	Front	Fitting Instructions
FK34	2 x Bracket	Toyota LandCruiser 78 Series	Rear Sway Bar Mounts	Fitting Instructions
FK35	1 x Spacer 2 x Bolt 2 x Nut 2 x Washer	Ford F250, F350 1999 to 2004 / F250, F350 2005 to 2008 Xtra Cab Models	Rear	Fitting Instructions
FK36	4 x Bracket 8 x Bolt M8 x 1.25 x 20 8 x Nut M8 x 1.25 16 x Washer	Ford F250, F350 2005 to 2008 V8 Diesel Coil Spring Models	Front	Fitting instructions supplied with kit
FK37	1 x Bracket 2 x Bump Stop Spacer 1 x Extension Plate 4 x Packer 2 x Bolt M14 x 1.5 2 x Nut M14 x 1.5 8 x Washer 2 x Bolt M12 x 1.25 2 x Nut M12 x 1.25 4 x Bolt M8 x 1.25 x 20 4 x Flanged Nuts M8 x 1.25	Jeep Wrangler JK LHD 2006 to 2017 2 & 4 Door Models	Rear	Fitting instructions supplied with kit
FK38	2 x Anti-Inversion Plate	Toyota LandCruiser 76 Series Wagon	Rear	Fitting instructions supplied with kit
FK39	1 x Bracket 2 x Bump Stop Spacer 1 x Extension Plate 4 x Packer 2 x Bolt M14 x 1.5 2 x Nut M14 x 1.5 8 x Washer 2 x Bolt M12 x 1.25 2 x Nut M12 x 1.25 4 x Bolt M8 x 1.25 x 20 4 x Flanged Nut M8 x 1.25	Jeep Wrangler JK RHD 2006 to 2017 2 & 4 Door Models	Rear	Fitting instructions supplied with kit
FK40	4 x Bump Stop Spacer 2 x Bolt M10 x 1.5 x 75 4 x Bolt M8 x 1.25 x 70 4 x Washer 2 x Flanged Nut 4 x Nut Nyloc	Jeep Wrangler JK Off Road Use	Front & Rear	Fitting instructions supplied with kit
FK41	2 x Bracket Assembly Bump Stop Spacer	Nissan GU Patrol - Leaf Sprung	Rear	Fitting instructions supplied with kit
FK42	2 x Sway Bar Packer 4 x Bolt M10 x 1.25 x 35 4 x Flat Washer M10 4 x Spring Washer M10	Nissan Xterra 2005 on	Rear	Fitting instructions supplied with kit
FK43	4 x Backing Plate 4 x Backing Plate Wear Clip 4 x Bolt M8 x 1.25 4 x Nyloc Hex Lock Nut 4 x Tube Spacer	Nissan Y61 Patrol - Leaf Sprung	Rear	Fitting instructions supplied with kit
FK44	2 x Saddle Bracket 2 x HD Bar Bracket (1 x RH, 1 x LH) 10 x Flat Washer M8 x 17 10 x Bolt M8 x 1.25 x 25 10 x M8 Spring Washer	Toyota LandCruiser 76/78/79 Series	Rear	Fitting instructions supplied with kit
FK45	2 x Axle Mount Bracket (1 x RH, 1 x LH) 1 x OMEU74 U Bolt 1 x OMEU75 U Bolt 2 x Saddle Bracket 1 x Brake Line Bracket 2 x Dropper Bracket (1 x RH, 1 x LH) 3 x Spacer Wing Mount 1 x Grub Screw M10 x 1.25 x 10 1 x M10 Flat Washer 1 x Nut Flange M10 x 1.25 9 x Flat Washer M8 x 17 9 x BZ Bolt M8 x 1.25 x 25	Toyota LandCruiser 76/78/79 Series	Rear	Fitting instructions supplied with kit

cont.

SPECIFICATIONS - FITTING KITS

SUSPENSION FITTING KITS

Part No.	Contains	Vehicle	Position	Refer to:
FK45 (cont.)	9 x Spring Washer M8 x 3/32 x 3/32	Toyota LandCruiser 76/78/79S	Rear	Fitting instructions supplied with kit
FK46	2 x Front Brake Line Bracket (1 x RH, 1 x LH) 2 x Rear Brake Line Bracket (1 x RH, 1 x LH) 1 x Hand Brake Bracket 6 x Bolt M6 x 1.0 x 20 8.8BZ 10 x Washer M6 x 20 16G 5 x Nyloc Nut M6 x 1 2 x Spring Washer M6 x 2.5 x 1.6 2 x Caged Nut M6 1.7 - 2.5	Jeep Wrangler JK Off Road Use	Front Rear	
FK47	1 x Track Bar Bracket 1 x Track Bracket Spacer 2 x U Bolt 1 x Bolt M14 x 1.5PX80 2 x Spacing Washer M14 x 23.5 x 5mm 1 x Nyloc Nut M14 x 1.5	Jeep Wrangler JK LHD Off Road Use	Rear	
FK47RHD	1 x Track Bar Bracket 1 x Track Bar Bracket Spacer 2 x U Bolt 1 x Bolt M14 x 1.5PX80 2 x Spacing Washer M14 x 23.5 x 5mm 1 x Nyloc Nut M14 x 1.5	Jeep Wrangler JK RHD Off Road Use	Rear	
FK48	2 x Front Sway Bar Link 2 x Rear Sway Bar Link 2 x Dis-Connect Pin 2 x Park Pin 2 x Sway Bar Bracket (1 x RH, 1 x LH) 2 x R-Clip 3.0 TZP 2 x Bolt 7/16 x 3 1/2 GR5 4 x Flat Washer 7/16 2 x Spring Washer 7/16 x 5/32 x 3/32 2 x Nut 7/16 2 x Nyloc Nut M12 2 x Nyloc Nut M10 x 1.25 2 x Flat Washer 1/2 x 1 1/8 x 3mm 2 x Flat Washer M10 x 20.6 x 2mm Fitting Grease	Jeep Wrangler JK Off Road Use	Front Rear	
FK49	8 x Driveline Packer 3 x Crossmember Spacer 2 x Flange Bolt M14 x 1.5 x 110 GR10.9 2 x Flange Bolt M14 x 1.5 x 10 GR10.9 4 x Flange Nut Conelock M14 x 1.5 Class 10 3 x Bolt M12 x 1.5 x 50mm 8.8 3 x Flat Washer 1/2 x 1 1/8 x 3mm 3 x Spring Washer 1/2 x 3/16 x 1/8 2 x Cable Tie 4.8 x 200mm	Jeep Wrangler JK Off Road Use	Front Rear	
FK50	1 x Stabiliser Plate 1 x Stabiliser Spacer 1 x Bolt M10 x 1.25 x 25 8.8 1 x Flat Washer M10 x 20.6 x 2mm 1 x Flange Nut M10 x 1.25 FP	Jeep Wrangler JK 2006 to 2017 2 & 4 Door Models	Front	Fitting instructions supplied with kit NB: Mandatory on 06 to 08 LHS models when fitting OMESD48.
FK51	2 x Brake Proportioning Bracket 2 x Flange Nut M8 x 1.25 BZ 2 x Flat Washer M8 x 17 x 1.2 2 x Bolt M8 x 1.25PX20	Toyota LandCruiser pre 08/2016 production 70S DC / 76S Wagon / 78S / 79S SC	Rear	Fitting instructions supplied with kit NB: Check 79S & 70S DC prior to kit selection. Not required for BP-51
FK53	4 x Driveline Packer 2 x Flange Bolt M14 x 1.5 x 110 GR10.9 2 x Flange Nut Conelock M14 x 1.5 Class 10	Jeep Wrangler JK 2006 to 2017 2 & 4 Door Models & Off Road Use	Front	Fitting instructions supplied with kit
FK56	1 x Packer Strut 5mm	Ford Everest 15 to 18 PXII 2015 to 2018 PXI 2011 to 2015 Mazda BT-50 11 to 20	Front	Fitting instructions supplied with kit
FK57	12 x Flat Washer M14 x 25 x 4 2 x Spring Washer M14 x 4mm x 3mm 2 x Female Bolt M10 x 25 x 1.5 8.8	Ford Ranger 11 to 22 Mazda BT-50 11 to 20	Centre Bearing	Fitting instructions supplied with kit
FK58	2 x Brake Proportioning Bracket 2 x Flange Nut M8 x 1.25 BZ 2 x Flat Washer M8 x 17 x 1.2 2 x Bolt M8 x 1.25PX20 4.6 2 x Spring Washer M8 x 3/32 x 3/32	Toyota LandCruiser pre 08/2016 production 70S DC / 76S Wagon / 78S / 79S SC	Rear	Fitting instructions supplied with kit NB: Check 79S & 70S DC prior to kit selection. Not required for BP-51
FK59	1 x Brake Prop. Bracket	Toyota HiLux / Vigo 05 to 15	Rear	Fitting instructions supplied with kit

cont.

SPECIFICATIONS - FITTING KITS

SUSPENSION FITTING KITS

Part No.	Contains	Vehicle	Position	Refer to:
FK59 (cont.)	1 x Bolt M8 x 1.25PX20 8.8 1 x Hex Lock M8 x 1.25 2 x Flat Washer M8 x 17 x 1.6 1 x Spring Washer M8 x 3/32 x 3/32	Toyota HiLux / Vigo 2005 to 2015	Rear	Fitting instructions supplied with kit
FK61	1 x Rear Panhard Bracket 1 x Spacer Bracket 2 x U Bolt 1 x M14 x 1.5 x 80 Bolt 1 x M14 x 1.5 Nyloc Nut 2 x M14 x 23.5 x 5mm Spacing Washer 2 x Bump Spacer Bracket 4 x M8 x 1.25 x 20 Hex Bolt 4 x M8 x 1.25 Nut Flange 4 x M8 x 17 x 1.6 Flat Washer	Jeep Wrangler JK 2" 2006 to 2017 RHD	Rear	Fitting instructions supplied with kit
FK62	2 x Front Bracket 2 x Rear Bracket 4 x M8 x 1.25 Bolt 8 x M8 x 17 Flat Washer 8 x M8 Nut Flange 4 x M8 x 1.25 x 50 Bolt	Land Rover Defender 110 & 130 Long Travel	Front Rear	Fitting instructions supplied with kit
FK63	2 x Front Bracket 2 x Rear Bracket 16 x M8 x 1.25 x 25 Bolt 16 x M8 x 17 Flat Washer 16 x M8 Nut Flange 8 x M10 Screw Hex 8 x M10 Flat Washer 8 x M10 Nut Flange	Land Rover Defender 110 & 130 Long Travel	Front Rear	Fitting instructions supplied with kit
FK64	1 x LH Bracket 1 x RH Bracket	Defender 110 & 130 / 110 & 130 Long Travel Discovery to1998 Land Rover 90 Series Range Rover To 5/1995	Rear	Fitting instructions supplied with kit
FK65	1 x LH Bracket 1 x RH Bracket 2 x M8 Caged Nut 2 x Bolt M8 x 16 x 1.25 2 x Flat Washer M8 x 17 2 x Spring Washer M8	Toyota LandCruiser pre 08/2016 production 70S DC / 76S Wagon / 78S / 79S SC	Front Brakes	Fitting instructions supplied with kit
FK66	2 x Bracket Leaf Cable 2 x Hex HD Bolt M8 x 16 x 1.25 2 x Hex Lock Nut Nyloc M8 x 1.25 4 x Flat Washer M8 x 17 x 1.6 ZP	Isuzu DMAX CC & LSM 2012 on Models	Rear	Fitting instructions supplied with kit
FK68	2 x Front Sway Bar Link 2 x Dis-Connect Pin 2 x Park Pin 1 x RH Sway Bar Bracket 1 x Sway Bar Bracket 2 x R-Clip 3.0 Tzp 2 x Bolt 7/16 x 3 1/2 GR5 4 x Flat Washer 7/16 2 x Spring Washer 7/16 x 5/32 x 3/32 2 x Nut 7/16 2 x Nut Nyloc M12 2 x Nut Nyloc M10 x 1.25 2 x Flat Washer 1/2 x 1 1/8 x 3mm 2 x Flat Washer M10 x 20.6 x 2mm Fitting Grease	Jeep Wrangler JK 2006 to 2017	Front	
FK69	1 x Bracket Panhard Superduty	Ford F250/F350 08 to 17	Front	Fitting instructions supplied with kit
FK70	1 x Bracket RAD ARM GEN3 Superduty R 1 x Bracket RAD ARM GEN3 Superduty L 4 x Bolt Hex M18 2.5 x 130 GR10.9 4 x Nut Nyloc M18 2.5 GR10.9 8 x Washer Flat 3/4 Zinc 2 x Bolt M12 x 1.75 x 35MMZP 2 x M12 1.75 Nyloc 2 x M12 Spring Washer 4 x M12 Flat Washer	Ford F250, F350 2011 to 2017	Front	Fitting instructions supplied with kit
FK71	1 x Bracket Brakeline Superduty R	Ford F250, F350 2008 to 2017	Front	Fitting instructions supplied with kit

cont.

SPECIFICATIONS - FITTING KITS

SUSPENSION FITTING KITS

Part No.	Contains	Vehicle	Position	Refer to:
FK71 (cont.)	1 x Bracket Brakeline Superduty L 2 x Plate ESC Outside Superduty 2 x Plate ESC Inside Superduty 2 x Bracket ESC Top Superduty 4 x Bolt HXHD M6 x 1.0 x 25 GR8.8 BTZP480 4 x Nut Hex Nyloc M6 x 1.0 GR8.8 BTZP480 8 x Washer F M6 x 16 x 1.2 PTZP480 2 x Bolt M8 x 1.25 x 70 CUP SQU BLKZP 2 x Nut Hex Nyloc M8 x 1.25 GR8.8 BTZP480 2 x Nut M10 Caged 1231-B 2 x M10 1.5 x 20 ZP 2 x M10 Spring Washer 2 x M10 Flat Washer	Ford F250, F350 2008 to 2017	Front	Fitting instructions supplied with kit
FK72	2 x Bracket Sway Bar Superduty 4 x Bolt M12 x 1.75 x 35MMZP 4 x M12 x 1.75 Nyloc Nut 4 x Washer Spring 1/2 8 x M12 Flat Washer	Ford F250, F350 2008 to 2017	Front	Fitting instructions supplied with kit
FK73	2 x Spacer Bump Front Superduty 2 x M8 1.25 x 50 GR8.8 2 x M8 Flat Washer 2 x M8 Spring Washer	Ford F250, F350 2008 to 2017	Front	Fitting instructions supplied with kit
FK74	1 x Packer Trim 10mm F Superduty	Ford F250/F350 08 to 17	Front	
FK76	2 x Saddle Bracket 2 x HD Bar Bracket (1 x RH, 1 x LH) 10 x Flat Washer M8 x 17 10 x Bolt M8 x 1.25 x 25 10 x M8 Spring Washer	Toyota LandCruiser 70S DC / 78S / 79S SC Models with OE axle sway bar mount	Rear	Fitting instructions supplied with kit
FK77	2 x Axle Mount Bracket (1 x RH, 1 x LH) 1 x OMEU74 U Bolt 1 x OMEU75 U Bolt 2 x Saddle Bracket 1 x Brake Line Bracket 2 x Dropper Bracket (1 x RH, 1 x LH) 3 x Spacer Wing Mount 1 x Grub Screw M10 x 1.25 x 10 1 x M10 Flat Washer 1 x Nut Flange M10 x 1.25 9 x Flat Washer M8 x 17 9 x BZ Bolt M8 x 1.25 x 25 9 x Spring Washer M8 x 3/32 x 3/32	Toyota LandCruiser 70S DC / 78S / 79S SC Models without OE sway bar provision	Rear	Fitting instructions supplied with kit
FK78	1 x Bracket	Nissan GU Cab Chassis	Rear	Fitting instructions supplied with kit
FK79	1 x Strut Packer	Jeep WK2	Front	
FK80	1 x Bracket RAD ARM GEN3 Superduty R 1 x Bracket RAD ARM GEN3 Superduty L 4 x Bolt Hex M18 2.5 x 130 GR10.9 4 x Nut Nyloc M18 2.5 GR10.9 8 x Washer Flat 3/4 Zinc 2 x Bolt M12 x 1.75 x 35MMZP 2 x M12 1.75 Nyloc 2 x M12 Spring Washer 4 x M12 Flat Washer	Ford F250, F350 2008 to 2010	Front	Fitting instructions supplied with kit
FK81	1 x Caster Plate L 1 x Caster Plate R 4 x M8 x 1.25P x 20 4 x Hex Nut Nylon 8 x M8 Flat Washer 1 x Nylon Nut M18 1 x 3/4 Flat Washer	Ford F250, F350 2008 to 2017	Front	Fitting Instructions
FK82	2 x Brake Line Drop Bracket 2 x M8 x 1.25P x 20 1 x Hex Nut Nylon 3 x Flat Washer M8 x 17 1 x M8 Spring Washer 1 x M8 Caged Nut	Toyota LandCruiser 70S DC / 76S Wagon / 78S / 79S SC 2014 to 08/2016	Rear Brake Line	Fitting Instructions
FK83	2 x Bump Spare Plate	Navara NP300 15 on Series 1, 2, 3, 4 & 5	Rear Leaf Spring	Fitting Instructions
FK84	1 x Plate Packer	Navara NP300 15 on Series 1, 2, 3, 4 & 5	Front Strut	

cont.

SPECIFICATIONS - FITTING KITS

SUSPENSION FITTING KITS

Part No.	Contains	Vehicle	Position	Refer to:
FK85	2 x Sway Bar Brackets 1 x Pot Bracket 2 x M12 x 1.75 x 30 Bolt 4 x Washer M12 x 27 x 4mm 2 x M12 x 1.75 Nyloc Nut 1 x M8 x 1.25 x 20 Bolt 1 x Washer M8 x 17 x 1.6m	Navara NP300 15 on Series 1, 2, 3, 4 & 5	Rear Coil Spring	Fitting Instructions
FK86	1 x Extension Bracket 2 x Bolt M6 x 10 2 x M6 Spring Washer 2 x Washer M6 x 1.6 x 20	Toyota HiLux 2015 on SR5 Model	Rear	Fitting Instructions
FK87	2 x Bolt M8 x 1.25 x 12 HD TZP480 1 x Bracket Colorado Brake Line 1 x Bracket Colorado Brake Line 2 x Nut Hex Lock Nyloc M8 x 1.25 2 x Bolt M8 x 1.25 x 16 Hex HD TZP480 8 x Washer Flat M8 x 20 x 2 Black	Holden Colorado 2016 on	Rear	Fitting instructions supplied with kit
FK89	3 x Spacer Cross Member 3 x Bolt M12 x 1.5 x 50mm Class 8.8 ZP 3 x Washer Flat 1/2 x 1, 1/8 x 3mm ZP 3 x Washer Spring 1/2 x 3 / 16 x 1/8 ZP	Jeep Wrangler JK 2006 to 2017	Cross Member Spacer Kit	Fitting Instructions
FK91	1 x Bolt M16 x 2.0 x 100 10.9 1 x Nut M16 x 2.0 10.9	Chevrolet Colorado 2015 on USA model	Rear Leaf Springs	Fitting Instructions
FK92	2 x Spacer JK Bump Stop Front 2 x Bracket Bump Spacer JL	Jeep Wrangler JL 2018 on	Front	Fitting instructions supplied with kit
¹ FK93	2 x Front Sway Bar Link 2 x Rear Sway Bar Link	Jeep Wrangler JL 2018 on	Front Rear	Fitting Instructions
FK94	1 x Packer 5mm, Strut PXIII	Ford Ranger USA model Ranger PXIII / Everest MY19 2018 to 2021	Front	Fitting instructions supplied with kit
FK95	2 x 14 x 1.5 x 100 10.9 Bolt 2 x 14 x 1.5 Class 10 Nut	Ford Ranger USA model / Ranger 2022 on / Ranger PXIII	Rear	Fitting instructions supplied with kit
FK96	1 x Panhard Bracket 2 x Bump Stops 1 x Fitting Kit 6177431	Suzuki Jimny 2018 on	Rear Axle	Fitting Instructions
FK97	1 x Sensor Bracket	Suzuki Jimny 2018 on	Rear	Fitting Instructions
FK99	1 x Brake Extension Bracket 1 x Locate Plate 3 x Bolt HXHD M6 x 1.0 x 20 PC8.8 TZP480 6 x Flat Washer M6 x 16 x 1.2 HV300 ZP 3 x Nut Hex Nyloc 6 x 1.0 TZP480 2 x Bolt HXHD FL M12 x 1.25 x 150 PC11.9 ZAB1000 4 x Washer Flat M12 x 26 x 4 HV300 TZP480	Suzuki Jimny 2018 on	Rear	Fitting instructions supplied with kit
FK100	4 x Bump Spacer Plate 4 x COHD Bolt M8 x 1.25 x 35 BZP 4 x Nut Hex Nyloc M8 x 1.25 ZNB480 4 x Washer Flat M8 x 16.6 x 1.2 BTZP480	Jeep Wrangler JL 2018 On SWB / LWB 3.6L Petrol Engine & LWB 2.2L Diesel Engine Models	Rear	
FK102	Dodge Rear Shock Folded Steel Tool	Chrysler Dodge RAM 1500 DS	Rear	
FK105	2 x Sway Bar Link Front 2 x Sway Bar Link Rear 1 x Washer 12.1 ID x 40 OD x 4mm 1 x 250µm x 200mm Plastic Tubing OME	Jeep Wrangler JL	Front Rear	Fitting instructions supplied with kit
FK109	1 x Track Bar Rear Assembly Bracket 1 x Bolt HXHD FL M16x2.0x90 1 x nut flange M16x2.0 1 x track bar bracket spacer 1 x Bolt HXHD M14x1.5x40 1 x Bolt HXHD FL M8x1.25x20 1 x Nut Flange M8x1.25 1 x Hardline relocation bracket	Ford Bronco 2021 On (USA)	Rear	Fitting instructions supplied with kit
FK110	4 x front strut plate spacer	Ford Bronco 2021 On (USA)	Front	Fitting instructions supplied with kit
FK111	4 x Plate Spacer 4 x Plate Spacer 6 x nut flange M10x1.5 PC10 ZAS1000	Ford Bronco 2021 On (USA)	Rear	Fitting instructions supplied with kit
FK112	1 x Packer Strut (not USA Ranger model)	Ford Ranger MY22/Everest MY22	Front	Fitting instructions supplied with kit
FK113	2 x Bolt HXHD FL M10 x 1.5 x 75 2 x Washer Flat M10 x 25 x 3 6 x Washer Flat M10 x 30 x 5	Ford Ranger 2022 on (not USA Ranger model)	Rear	Fitting instructions supplied with kit

1. When remaining stock is exhausted no further product will be available.

cont.

SPECIFICATIONS - FITTING KITS

SUSPENSION FITTING KITS

Part No.	Contains	Vehicle	Position	Refer to:
FK113 (cont.)	2 x Spacer Zeon Internal Hawse	Ford Ranger 2022 on (not USA Ranger model)	Rear	Fitting instructions supplied with kit
FK114	1 x Bracket Rear Headlight	Ford Ranger 2022 on (not USA)	Rear	Fitting instructions supplied with kit
FK115	1 x Bump Stop Adapter	Ford Ranger 2022 on (not USA)	Rear	Fitting instructions supplied with kit
FK116	1 x Fitting hose barb 8mm to 8mm 1 x hose 8id x 1.5mm wall x 150mm	Ford Ranger 2022 on (not USA)	Rear	Fitting instructions supplied with kit
FK119	1 x Reverse Light Assembly RHS 1 x Reverse Light Assembly LHS	Toyota Landcruiser 300 Series	Rear	Fitting instructions supplied with kit
FKWTJ01	1 x 45mm Panhard Rod Extention Bracket 2 x Spacer Washer Flat 12 x 36 x 4 ZTY120 3 x Bolt HXHD M12 x 1.25 x 30 PC8.8 ZP 6 x Washer Flat 1/2 x 1 1/8 x 3mm ZP 3 x Spring Washer 1/2 x 3/16 x 1/8 ZP 3 x Nut Hex M12 x 1.25 TZP480	Jeep Wrangler TJ RHD	Rear	Fitting instructions supplied with kit
FKWTJ02	1 x Extention Bracket 1 x Sleeve Panhard Rod Extention 1 x Bolt HXHD M12 x 1.25 x 25 ZP 1 x Bolt HXHD M12 x 1.25 x 65 PC8.8 ZP 1 x Bolt HXHD M10 x 1.25 x 25 PC8.8 ZP 2 x Nut Hex M12 x 1.25 TZP480 1 x Nut Hex M10 x 1.25 TZP480 4 x Nut Hex M10 x 1.25 TZP480 2 x Washer Spring 1/2 x 3/16 x 1/8 ZP 2 x Washer Flat M10 x 25 x 3 TZP480 1 x Washer Spring M10 x 1/8 x 1/8 TZP480	Jeep Wrangler TJ & TJ Unlimited 1997 to 2006 LHD	Rear	Fitting instructions supplied with kit
GQGK01	4 x Spacer Plate 8 x Hex. Bolt 8 x Flat Washer 8 x Spring Washer	Nissan GQ Y61 Patrol Off Road Use, GQ Y60 SWB, LWB & CC coil spring / Ford Maverick	Gearbox Cross Member	Manual Sec. 4 GFI Patrol Gearbox Spacer Kit
GQGK02	4 x Spacer Plate 9 x Spacer 12mm 8 x Bolt M12 x 1.25 x 70mm 17 x Spring Washer 17 x Flat Washer 6 x Bolt M8 x 1.25 x 40mm 3 x Bolts M8 x 1.25 x 35mm	Nissan GU Y61 Patrol SWB Model	Gearbox	Fitting instructions
JWKG01	6 x Spacer Plate 6 x Bolt Spacer 6 x 2" Bolt	Jeep Wrangler TJ & TJ Unlimited to 2003 / YJ 1986 to 1996	Gearbox	Fitting instructions supplied with kit
JWKG02	6 x Spacer Plate 6 x Bolt 17 x Flat Washer 17 x Spring Washer	Jeep Wrangler TJ & TJ Unlimited 2003 to 2006 Manual Models	Gearbox	Fitting instructions
JWKG03	8 x Spacer Plate 8 x Bolt 8 x Flat Washer 8 x Spring Washer	Jeep Wrangler TJ & TJ Unlimited 2003 to 2006 Auto Models	Gearbox	Fitting instructions
OMETH001	1 x Bearing Plate 1 x Rubber Isolator 2 x Loose Rubber Bushes 1 x Dome Washer 1 x Cupped Washer 1 x Crush Tube 3 x Mounting Nuts M10 x 1.25 Dirt Shield Included	Mitsubishi Pajero Sport 15 on / Challenger 10 to 15 / Triton MQ / MN / ML	Front One side only on ML	
OMETH002	1 x Bearing Plate With Bonded Lower Bush 1 x Rubber Isolator 2 x Bonded Rubber Bushes (One On Washer One On Bearing Plate) 1 x Loose Washer 1 x Bonded Washer (One On Rubber Bush) 3 x Mounting Nuts M10 x 1.25	Toyota 4 Runner (USA) 03 on / FJ Cruiser 06 on / Fortuner 04 on / HiLux 05 on / Prado 150 Series / Prado 120 Series / Tacoma V6 05 to 15 / Tacoma 16 on	Front One side only on HiLux 05 On	
OMETH003	1 x Bearing Plate With Bonded Lower Bush 1 x Rubber Isolator 2 x Bonded Rubber Bushes (One On Washer One On Bearing Plate) 1 x Loose Washer 1 x Bonded Washer (One On Rubber Bush) 4 x Mounting Nuts M10 x 1.25	Toyota LandCruiser 200 Series & 200 Series Armoured	Front One side only 200 Series	

cont.

SPECIFICATIONS - FITTING KITS

SUSPENSION FITTING KITS

Part No.	Contains	Vehicle	Position	Refer to:
OMETH004	1 x Bearing Plate With Bonded Lower Bush 1 x Rubber Isolator 2 x Bonded Rubber Bushes (One On Washer One On Bearing Plate) 1 x Loose Washer 1 x Bonded Washer (One On Rubber Bush) 3 x Mounting Nuts M10 x 1.50	Holden Trailblazer 2017 on / Colorado 7 2013 to 2016 / Colorado 2012 on Isuzu DMAX 2012 on / MU-X 2013 on / Mazda BT-50 20 on	Front One side only	
OMETH005	1 x Bearing Plate 1 x Rubber Isolator & Bush Combined 1 x Loose Rubber Bush 2 x Cupped Washers Sized Differently 1 x Crush Tube 3 x Mounting Nuts M10 x 1.50	Navara D23 NP300 15 on Series 1, 2, 3, 4 & 5 / D40 05 on / Pathfinder R51 05 to 14 / Xterra 05 on Suzuki Equator USA only	Front One side only D40	
OMETH006	1 x Bearing Plate 1 x Rubber Isolator 2 x Loose Rubber Bushes 2 x Cupped Washers 1 x Crush Tube 3 x Mounting Nuts M12 x 1.75	Ford Everest 15 to 18 / Ford Ranger 11 to 22 / Mazda BT-50 11 to 20	Front One side only One side only	
OMETH007	1 x Bearing Plate 1 x Rubber Isolator 2 x Loose Rubber Bushes 1 x Dome Washer 1 x Cupped Washer 1 x Crush Tube 3 x Mounting Nuts M10 x 1.25	Mitsubishi SWB Pajero 2000 on / Montero 2000 on / LWB Pajero 2000 to 2006 / Montero 2000 to 2006 / Pajero 2007 on All LWB	Front One side only	
XJGK01	4 x 10mm Packer 2 x 6mm Packer 4 x M10 x 1.5 x 50 8.8 Bolt 4 x 3/8 x 3/4 Flat Washer 4 x M10 Spring Washer 1 x 25mm Spacer 1 x M8 x 1.25 x 40 8.8 Bolt 1 x M8 x 17 Flat Washer 1 x M8 Spring Washer	Jeep Cherokee XJ Wagon 1984 to 2001	Gearbox	Fitting instructions supplied with kit

SPECIFICATIONS - LEAF SPRINGS

LEAF SPRING SERVICE PARTS

Spring Part Number	Replacement Centre Bolt	Interleaf Liner		Clip Liner		Trim Packer (EA)	Leaf Spacers (5PK)	Extra Leaf	Extra Leaf Spacer Kit	Extra Leaf / Trim Packer Centre Bolt
		SRBC60A	SRBC60B	Part No.	Qty.					
CS001F	UCB8	0	8	CLK13	1	ELSK06	ELSK04	D3XL	N/A	UCB8
CS001R	UCB8	0	6	CLK14	1	ELSK06	ELSK04	D4XL	N/A	UCB8
CS002F	UCB8	0	8	CLK13	1	ELSK06	ELSK04	D3XL	N/A	UCB8
CS002R	UCB8	0	6	CLK14	1	ELSK06	ELSK04	D4XL	N/A	UCB8
CS003F	UCB3	0	4	CLK11	1	ELSK06	ELSK04	D1XL	N/A	UCB3
CS003R	UCB4	0	6	CLK201	1	ELSK06	ELSK04	D8XL	N/A	UCB4
CS004F	UCB3	0	6	CLK11	1	ELSK06	ELSK04	D1XL	N/A	UCB3
CS004RA	UCB2	0	6	CLK113A	1	ELSK06	ELSK04	D2XL	N/A	UCB2
CS004RB	UCB2	0	6	CLK113B	1	ELSK06	ELSK04	D2XL	N/A	UCB2
CS005F	UCB3	0	6	CLK11	1	ELSK06	ELSK04	N/A	N/A	N/A
CS005RA	UCB2	0	6	CLK113A	1	ELSK06	ELSK04	D2XL	N/A	UCB2
CS005RB	UCB2	0	6	CLK113B	1	ELSK06	ELSK04	D2XL	N/A	UCB2
CS006F	UCB5	0	7	CLK57	1	ELSK06	ELSK04	D16XL	N/A	UCB5
CS006R	UCB4	0	6	CLK39	1	ELSK06	ELSK04	D25XL	N/A	UCB4
CS007F	UCB5	0	7	CLK57	1	ELSK06	ELSK04	N/A	N/A	N/A
CS007R	UCB4	0	6	CLK39	1	ELSK06	ELSK04	D25XL	N/A	UCB4
CS008FA	UCB7	0	6	CLK9	1	ELSK05	ELSK10	D17XL	N/A	UCB7
CS008FB	UCB7	0	4	CLK9	1	ELSK05	ELSK10	D17XL	N/A	UCB7
CS008R	UCB4	0	6	CLK39	1	ELSK06	ELSK04	D25XL	N/A	UCB4
CS009FA	UCB7	0	4	CLK9	1	ELSK05	ELSK10	D17XL	N/A	UCB7
CS009FB	UCB7	0	4	CLK9	1	ELSK05	ELSK10	D17XL	N/A	UCB7
CS009R	UCB6	0	3	CLK17	1	ELSK05	ELSK10	D5XL	N/A	UCB6
CS010FA	UCB5	0	6	CLK3	1	ELSK05	ELSK10	D11XL	N/A	UCB5
CS010FB	UCB5	0	6	CLK3	1	ELSK05	ELSK10	D11XL	N/A	UCB5
CS010R	UCB6	0	3	CLK17	1	ELSK06	ELSK04	D5XL	N/A	UCB6
CS011FA	UCB5	0	6	CLK3	1	ELSK05	ELSK10	N/A	N/A	N/A
CS011FB	UCB5	0	6	CLK3	1	ELSK05	ELSK10	N/A	N/A	N/A
CS011R	UCB1	0	10	CLK4	1	ELSK05	ELSK10	D12XL	N/A	UCB1
CS012FA	UCB7	0	2	CLKJ1	1	N/A	N/A	D20XL	N/A	UCB7
CS012FB	UCB7	0	2	CLKJ1	1	N/A	N/A	D20XL	N/A	UCB7
CS012R	UCB1	0	10	CLK4	1	ELSK05	ELSK10	D12XL	N/A	UCB1
CS013FA	UCB7	0	2	CLK13D	1	N/A	N/A	D20XL	N/A	UCB7
CS013FB	UCB7	0	2	CLK13D	1	N/A	N/A	D20XL	N/A	UCB7
CS013R ¹	UCB17	0	4	CLK15D	1	ELSK06	ELSK04	D14XL	N/A	UCB17
CS014F	UCB09	0	4	CLK13D	1	ELSK05	ELSK10	D23XL	N/A	UCB09
CS014R ¹	UCB17	0	4	CLK15D	1	ELSK06	ELSK04	D14XL	N/A	UCB17
CS015F ¹	UCB18	0	4	CLK6	1	N/A	N/A	N/A	N/A	N/A
CS015R ¹	UCB17	0	4	CLK15D	1	ELSK06	ELSK04	D14XL	N/A	UCB17
CS016F	UCB17	0	8	CLK39	1	ELSK05	ELSK10	D30XL	N/A	UCB17
CS016RA	UCB11	0	4	CLK6	1	ELSK06	ELSK04	D15XL	N/A	UCB11
CS016RB	UCB11	0	4	CLK6	1	ELSK06	ELSK04	D15XL	N/A	UCB11
CS017RA	UCB2	0	8	CLK221	1	ELSK06	ELSK04	D2XL	N/A	UCB2
CS017RB	UCB2	0	8	CLK221	1	ELSK06	ELSK04	D2XL	N/A	UCB2
CS018F	UCB18	0	10	CLK39	1	N/A	N/A	N/A	N/A	N/A
CS018R	UCB6	0	2	CLK18	1	ELSK05	ELSK10	N/A	N/A	N/A
CS019R	UCB6	0	2	CLK18	1	ELSK05	ELSK10	D6XL	N/A	UCB6
CS020R	UCB6	0	2	CLK18	1	ELSK05	ELSK10	D6XL	N/A	UCB6
CS021R	UCB6	0	2	CLK58D	1	ELSK05	ELSK10	D6XL	N/A	UCB6
CS022R	UCB5	0	6	CLK22	1	ELSK06	ELSK04	D32XL	N/A	UCB10
CS023R	UCB5	0	6	CLK22	1	ELSK06	ELSK04	N/A	N/A	N/A
CS024R	UCB15	0	4	CLKROD	1	ELSK05	ELSK10	N/A	N/A	N/A
CS026R	UCB17	0	4	CLK26D	1	ELSK05	ELSK10	D9XL	N/A	UCB17

1. When remaining stock of is exhausted no further product will be available.

cont.

SPECIFICATIONS - LEAF SPRINGS

LEAF SPRING SERVICE PARTS

Spring Part Number	Replacement Centre Bolt	Interleaf Liner		Clip Liner		Trim Packer (EA)	Leaf Spacers (5PK)	Extra Leaf	Extra Leaf Spacer Kit	Extra Leaf / Trim Packer Centre Bolt
		SRBC60A	SRBC60B	Part No.	Qty.					
CS027R	UCB17	0	4	CLK26D	1	ELSK05	ELSK10	D9XL	N/A	UCB17
CS028R	UCB12	0	4	CLK17	1	ELSK05	ELSK10	D19XL	N/A	UCB16
CS029R	UCB16	0	2	CLK17	1	ELSK05	ELSK10	D19XL	N/A	UCB16
CS030R	UCB13	0	2	CLKNN	1	ELSK05	ELSK10	D18XL	N/A	UCB14
CS031R	UCB13	0	2	CLKNN	1	ELSK05	ELSK10	D18XL	N/A	UCB14
CS032R	UCB13	0	2	CLKNN	1	ELSK05	ELSK10	D18XL	N/A	UCB14
CS033RA	UCB8	0	6	CLK33D	1	ELSK05	ELSK10	D22XL	N/A	UCB8
CS033RB	UCB8	0	6	CLK33D	1	ELSK05	ELSK10	D22XL	N/A	UCB8
CS034RA	UCB8	0	6	CLK3	1	ELSK05	ELSK10	D22XL	N/A	UCB8
CS034RB	UCB8	0	6	CLK3	1	ELSK05	ELSK10	D22XL	N/A	UCB8
CS035RA	UCB8	0	6	CLKJ2	1	ELSK05	ELSK10	D22XL	N/A	UCB8
CS035RB	UCB8	0	6	CLKJ2	1	ELSK05	ELSK10	D22XL	N/A	UCB8
CS036R	UCB09	0	4	CLKJ1	1	ELSK05	ELSK10	D24XL	N/A	UCB09
CS037R	UCB09	0	4	CLK4	1	N/A	N/A	D24XL	N/A	UCB09
CS038R	UCB7	0	4	CLK38D	1	N/A	N/A	D21XL	N/A	UCB7
CS039R	UCB7	0	4	CLK38D	1	N/A	N/A	D21XL	N/A	UCB7
CS040R	UCB5	0	2	CLK40D	1	ELSK06	ELSK04	D7XL	N/A	UCB5
CS041R	UCB5	0	2	CLK40D	1	ELSK06	ELSK04	D7XL	N/A	UCB5
CS042R	UCB5	0	4	CLK6	1	N/A	N/A	D10XL	N/A	UCB5
CS043R ¹	UCB14	0	4	CLK43D	1	ELSK05	ELSK10	D13XL	N/A	UCB14
CS043R-15	UCB14	0	4	CLK43D	1	ELSK05	ELSK10	D13XL	N/A	UCB14
CS044R ¹	UCB14	0	4	CLK43D	1	ELSK05	ELSK10	D13XL	N/A	UCB14
CS045R ¹	UCB14	0	4	CLK43D	1	ELSK05	ELSK10	D13XL	N/A	UCB14
CS046RA	UCB14	0	6	CLK6	1	ELSK05	ELSK10	N/A	N/A	N/A
CS046RB	UCB14	0	6	CLK6	1	ELSK05	ELSK10	N/A	N/A	N/A
CS047R ¹	UCB17	0	4	CLK6	1	ELSK05	ELSK10	D29XL	N/A	UCB17
CS048R	UCB10	0	2	CLK48D	1	N/A	N/A	D27XL	N/A	UCB10
CS049R ¹	UCB19	0	4	CLK4	1	ELSK05	ELSK10	D34XL	N/A	UCB19
CS053R	UCB5	0	2	CLK17	1	ELSK06	ELSK04	D32XL	N/A	UCB10
CS054R	UCB5	0	2	CLK17	1	ELSK06	ELSK04	D32XL	N/A	UCB10
CS055R		0	4	CLK55D	1	ELSK05	ELSK10	D28XL	N/A	N/A
CS056R	UCB19	0	4	CLK4	1	ELSK05	ELSK10	D34XL	N/A	UCB19
CS057R	UCB17	0	4	CLK57D	1	ELSK06	ELSK04	D35XL	N/A	UCB17
CS058R	UCB17	0	4	CLK58D	1	ELSK06	ELSK04	D35XL	N/A	UCB17
CS059R	UCB5	0	6	CLK4	1	N/A	N/A	D36XL	N/A	N/A
CS060R	UCB19	0	8	CLK15D	1	ELSK05	ELSK10	D34XL	N/A	UCB19
CS061R	UCB5	0	4	CLK4	1	ELSK05	ELSK10	D37XL	N/A	N/A
CS062R	UCB15	0	4	CLKROD	1	ELSK05	ELSK10	D26XL	N/A	UCB15
CS063R	UCB15	0	4	CLKROD	1	ELSK05	ELSK10	D26XL	N/A	UCB15
CS064R	UCB17	0	4	CLK15D	1	ELSK06	ELSK04	D38XL	N/A	UCB17
CS065R	UCB17	0	4	CLK15D	1	ELSK06	ELSK04	D38XL	N/A	UCB17
CS066R ¹	UCB17	0	10	CLK15D	1	ELSK06	ELSK04	D14XL	N/A	UCB4
CS068R ¹	UCB19	0	8	CLK39	1	ELSK05	ELSK10	D34XL	N/A	UCB19
CS069R ¹	UCB19	0	10	CLK15D	1	ELSK05	ELSK10	D34XL	N/A	UCB19
CS070R	UCB17	0	8	CLK58D	1	ELSK06	ELSK04	N/A	N/A	UCB17
CS071R ¹	UCB14	0	6	CLK43D	1	ELSK05	ELSK10	D13XL	N/A	UCB14
CS150R	UCB19	0	6	CLK33D	1	ELSK05	ELSK10	D31XL	N/A	UCB19
CS151R	UCB19	0	6	CLK33D	1	ELSK05	ELSK10	D31XL	N/A	UCB19
EL013R ¹	UCB19	2	2	ELSK01	1	ELSK06	ELSK04	EL14XL	ELSK13	N/A
EL014R ¹	UCB19	2	2	ELSK01	1	ELSK06	ELSK04	EL14XL	ELSK13	N/A
EL015R ¹	UCB19	2	2	ELSK01	1	ELSK06	ELSK04	EL14XL	ELSK13	N/A
EL043R	UCB19	2	4	ELSK01	1	ELSK05	ELSK10	EL13XL	ELSK12	N/A
EL044R	UCB19	4	2	ELSK01	1	ELSK05	ELSK10	EL13XL	ELSK12	N/A

1. When remaining stock is exhausted no further product will be available.

cont.

SPECIFICATIONS - LEAF SPRINGS

LEAF SPRING SERVICE PARTS

Spring Part Number	Replacement Centre Bolt	Interleaf Liner		Clip Liner		Trim Packer (EA)	Leaf Spacers (5PK)	Extra Leaf	Extra Leaf Spacer Kit	Extra Leaf / Trim Packer Centre Bolt
		SRBC60A	SRBC60B	Part No.	Qty.					
EL045R	UCB19	4	4	ELSK01	1	ELSK05	ELSK10	EL13XL	ELSK12	UCB19
EL049R	UCB19	4	2	ELSK01	1	ELSK05	ELSK10	EL34XL	ELSK12	N/A
EL066R ¹	UCB19	12	2	ELSK01	1	ELSK06	ELSK04	EL14XL	ELSK12	UCB10
EL068R ¹	UCB19	6	2	ELSK01	1	ELSK05	ELSK10	EL34XL	ELSK12	UCB19
EL069R ¹	UCB19	6	4	ELSK01	1	ELSK05	ELSK10	EL34XL	ELSK12	UCB4
EL071R	UCB19	6	4	ELSK01	1	ELSK05	ELSK10	EL13XL	ELSK12	UCB19
EL072R ¹	UCB19	2	2	ELSK01	1	ELSK05	ELSK10	EL39XL	ELSK12	N/A
EL073R ¹	UCB19	4	2	ELSK01	1	ELSK05	ELSK10	EL39XL	ELSK12	N/A
EL074R ¹	UCB19	4	4	ELSK01	1	ELSK05	ELSK10	EL39XL	ELSK12	N/A
EL077R	UCB21	12	0	ELSK01	1	N/A	N/A	EL40XL	N/A	UCB21
EL079R ¹	UCB19	4	4	ELSK01	1	ELSK06	ELSK04	EL14XL	N/A	N/A
EL080R ¹	UCB19	4	4	ELSK01	1	ELSK06	ELSK04	EL14XL	N/A	N/A
EL081R ¹	UCB10	4	6	ELSK01	1	ELSK06	ELSK04	EL14XL	N/A	N/A
EL082R ¹	UCB10	12	2	ELSK01	1	ELSK06	ELSK04	EL14XL	N/A	UCB10
EL083R ¹	UCB19	4	4	ELSK01	1	ELSK05	ELSK10	EL43XL	ELSK12	UCB19
EL084R ¹	UCB10	8	4	ELSK01	1	ELSK05	ELSK10	EL43XL	ELSK12	UCB10
EL085R ¹	UCB10	8	4	ELSK01	1	ELSK05	ELSK10	EL43XL	ELSK12	UCB4
EL086R ¹	UCB19	4	4	ELSK01	1	ELSK05	ELSK10	EL44XL	ELSK12	UCB19
EL087R ¹	UCB19	4	6	ELSK01	1	ELSK05	ELSK10	EL44XL	ELSK12	UCB19
EL088R ¹	UCB19	4	4	ELSK01	1	ELSK05	ELSK10	EL44XL	ELSK12	UCB19
EL089R ¹	UCB19	0	6	ELSK01	1	ELSK05	ELSK10	EL45XL	ELSK12	UCB19
EL090R ¹	UCB19	2	6	ELSK01	1	ELSK05	ELSK10	EL45XL	ELSK12	UCB19
EL091R ¹	UCB19	2	6	ELSK01	1	ELSK05	ELSK10	EL45XL	ELSK12	UCB19
EL092R	UCB19	4	4	ELSK01	1	ELSK05	ELSK10	EL43XL	ELSK12	UCB19
EL093R	UCB10	8	4	ELSK01	1	ELSK05	ELSK10	EL43XL	ELSK12	UCB10
EL094R	UCB10	8	4	ELSK01	1	ELSK05	ELSK10	EL43XL	ELSK12	UCB4
EL095R ¹	UCB17	2	4	ELSK01	1	ELSK05	ELSK10	EL46XL	ELSK12	N/A
EL096R ¹	UCB17	4	4	ELSK01	1	ELSK05	ELSK10	EL46XL	ELSK12	UCB17
EL100R	UCB5	2	2	CLS308240	4	ELSK05	ELSK10	EL47XL	ELSK12	UCB5
EL101R	UCB17	4	2	CLS308255	4	ELSK05	ELSK10	EL47XL	ELSK12	UCB17
EL102R ¹	UCB19	4	2	CLS308255	4	ELSK05	ELSK10	EL34XL	ELSK12	UCB19
				CLS308265	2					
EL103R ¹	UCB19	6	2	CLS308265	2	ELSK05	ELSK10	EL34XL	ELSK12	UCB19
				CLS308270	6					
EL104R ¹	UCB19	8	2	CLS308265	2	ELSK05	ELSK10	EL34XL	ELSK12	UCB4
				CLS308285	4					
EL105R	UCB19	4	2	CLS308245	2	ELSK05	ELSK10	EL45XL	ELSK12	UCB19
				CLS308255	4					
EL106R	UCB19	4	4	CLS308245	2	ELSK05	ELSK10	EL45XL	ELSK12	UCB19
				CLS308260	4					
EL107R	UCB19	4	4	CLS308245	2	ELSK05	ELSK10	EL45XL	ELSK12	UCB4
				CLS308285	4					
EL108R	UCB19	2	2	CLS308240	2	ELSK05	ELSK10	EL39XL	ELSK12	UCB19
				CLS308265	2					
EL109R	UCB19	4	2	CLS308255	4	ELSK05	ELSK10	EL39XL	ELSK12	UCB19
				CLS308265	2					
EL110R	UCB19	5	3	CLS308270	4	ELSK05	ELSK10	EL39XL	ELSK12	UCB19
				CLS308285	2					
EL111R	UCB19	4	2	CLS308250	4	ELSK05	ELSK10	EL46XL	ELSK12	UCB19
				CLS308265	2					
				CLS308295	2					
EL112R	UCB19	6	2	CLS308250	4	ELSK05	ELSK10	EL46XL	ELSK12	UCB4
				CLS308265	2					
				CLS3082100	2					

1. When remaining stock is exhausted no further product will be available.

cont.

SPECIFICATIONS - LEAF SPRINGS

LEAF SPRING SERVICE PARTS

Spring Part Number	Replacement Centre Bolt	Interleaf Liner		Clip Liner		Trim Packer (EA)	Leaf Spacers (5PK)	Extra Leaf	Extra Leaf Spacer Kit	Extra Leaf / Trim Packer Centre Bolt
		SRBC60A	SRBC60B	Part No.	Qty.					
EL113R	UCB19	4	4	CLS308260	4	ELSK06	N/A	EL14XL	ELSK13	N/A
				CLS308295	2					
EL114R	UCB19	4	4	CLS308260	4	ELSK06	N/A	EL14XL	ELSK13	N/A
				CLS308295	2					
EL115R	UCB10	4	6	CLS308265	4	ELSK06	N/A	EL14XL	ELSK13	N/A
				CLS3082105	2					
EL116R	UCB10	12	2	CLS3082100	4	ELSK06	N/A	EL14XL	ELSK13	UCB10
				CLS3082105	2					
EL117R	UCB19	6	2	CLS308255	4	ELSK05	ELSK10	EL44XL	ELSK12	UCB19
				CLS308260	2					
EL118R	UCB19	6	4	CLS308255	4	ELSK05	ELSK10	EL44XL	ELSK12	UCB4
				CLS308260	2					
EL119R	UCB19	6	2	CLS308260	6	ELSK05	ELSK10	EL44XL	ELSK12	UCB4
EL120R	UCB5	2	2	CLS308265	2	ELSK05	ELSK10	EL34XL	ELSK12	UCB5
				CLS308255	4					
EL121R	UCB5	4	2	CLS308265	2	ELSK05	ELSK10	EL34XL	ELSK12	UCB6
				CLS308255	4					
EL122RA	UCB19	6	0	CLS308245	4	ELSK05	ELSK10	D43XL	ELSK12	UCB19
				CLS308295	2					
EL122RB	UCB19	6	0	CLS308245	4	ELSK05	ELSK10	D43XL	ELSK12	UCB19
				CLS308295	2					
EL123R	UCB19	4	2	CLS308255	4	ELSK05	ELSK10	EL39XL	ELSK12	UCB19
				CLS308265	2					
EL124R	UCB19	6	2	CLS308265	2	ELSK05	ELSK10	EL39XL	ELSK12	UCB19
				CLS308270	6					
EL125R	UCB19	8	2	CLS308265	2	ELSK05	ELSK10	EL39XL	ELSK12	UCB4
				CLS308285	4					
EL126R	UCB19	2	2	CLS308240	2	ELSK05	ELSK10	EL34XL	ELSK12	UCB19
				CLS308265	2					
EL127R	UCB19	4	2	CLS308255	4	ELSK05	ELSK10	EL34XL	ELSK12	UCB19
				CLS308265	2					
EL128R	UCB19	5	3	CLS308270	4	ELSK05	ELSK10	EL34XL	ELSK12	UCB4
				CLS308285	2					
EL130R	UCB19	4	2	CLS308265	2	ELSK14	ELSK10	EL48XL	ELSK15	UCB19
				CLS308245	4					
EL131R	UCB19	4	4	CLS308265	2	ELSK14	ELSK10	EL48XL	ELSK15	UCB19
				CLS308255	4					
EL132R	UCB19	6	4	CLS308270	4	ELSK14	ELSK10	EL48XL	ELSK15	UCB4
				CLS308265	2					
PB007R	UCB5	0	2	TBA		N/A	ELSK10	N/A	N/A	N/A
PB008R	UCB5	0	2	TBA		N/A	ELSK10	N/A	N/A	N/A
PB009R	UCB5	0	4	TBA		N/A	ELSK10	N/A	N/A	N/A
PB010R	UCB5	0	4	TBA		N/A	ELSK10	N/A	N/A	N/A

SPECIFICATIONS - LEAF SPRINGS

LEAF SPRING SERVICE PARTS

SPRING EYE SLEEVES			
PART NUMBER	ID (MM)	OD (MM)	LENGTH (MM)
CBH154028	15	40	28
CBH27532569	27.5	32.5	69
CBH303549	30	35	49
CBH303559	30	35	59
CBH31536559	31.5	36.5	59
CBH31536569	31.5	36.5	69
CBH32737759	32.7	37.7	59
CBH354069	35	40	69
CBH37542559	37.5	42.5	59
CBH39544559	39.5	44.5	59
CBH404549	40	45	49
CBH404559	40	45	59
CBH404569	40	45	69

SPRING CLIPS			
PART NUMBER	LEAF WIDTH (MM)	CLIP WIDTH (MM)	CLIP LENGTH (MM)
2512074	70	25	120
2516474	70	25	164

RIVETS		
PART NUMBER	SIZE	LENGTH (MM)
3822	3/8	22
3824	3/8	24

EL SERVICE KITS	
PART NUMBER	DESCRIPTION
TB1001	TRU BLU NLGI2.9 Grease 450gm
TB1002	TRU BLU NLGI2.9 Grease 2.5kg
TB1003	TRU BLU NLGI2.9 Grease 20kg
OMECW2	2° Caster Wedge
ELSK01	Leaf Spring Clip Liner Kit
ELSK05	Leaf Trim Packer 10mm 60 Wide
ELSK06	Leaf Trim Packer 10mm 70 Wide
ELSK04	Leaf Spacers 1.6mm 70 Wide (5 pack)
ELSK10	Leaf Spacers 3mm 60 Wide (5 pack)
ELSK12	Extra Leaf Spacer Kit 60 Wide
ELSK13	Extra Leaf Spacer Kit 70 Wide
ELSK14	Leaf Spring Trim Packer
ELSK15	Extra Leaf Spacer Kit

LEAF SPRING TRIM PACKERS (Mild Steel 5mm Thick)				
PART NO.	WIDTH	LENGTH	HOLE DIA.	APPLICATIONS
TP01	70mm	140mm	10.3mm	TOYOTA 60, 75, NISSAN GQ / FORD MAVERICK CAB CHASSIS & NISSAN GQ UTE
TP02	70mm	140mm	8.7mm	TOYOTA 40, 42, 45, 47
TP03	60mm	140mm	10.3mm	NISSAN MQ, MITSUBISHI PAJERO, TRITON, L200
TP04	60mm	140mm	8.7mm	TOYOTA HILUX, 4RUNNER
TP05	50mm	120mm	8.7mm	SUZUKI SIERRA, SAMURAI (SJ413), SANTANA SAMURAI, HOLDEN DROVER

To be used to correct left to right trim problems. Maximum 2 plates (10mm). Order centre bolt separately. Refer Manual for Instructions.

BONDED RUBBER BUSHES			
PART NUMBER	ID (MM)	OD (MM)	LENGTH (MM)
CBH14405970	14	40	59/70
CBH14406073	14	40	60/73
CBH145357889	14.5	35	78/89
CBH148517689	14.8	51	76/89
CBH16455689	16	45	56/89
CBH185396489	18.5	39	64/89
CBH18544489	18	54	44/89

LEAF LINER KITS	
PART NUMBER	DESCRIPTION
IL01YE (Round)	Inter Leaf Liners x 6 Pieces
SLK60 (60mm Wide)	Noise - Service Liners x 4 Pieces
SLK70 (70mm Wide)	Noise - Service Liners x 4 Pieces
¹ SLO0530413	Inter Leaf Liners Large 4mm Thick
SRBC60A	Inter Leaf Linder HDPE Long
SRBC60B	Inter Leaf Linder HDPE Short

1. When remaining stock is exhausted no further product will be available.

LEAF SPRING CENTRE BOLT SLEEVES				
PART NO.	LENGTH	OD	ID	APPLICATIONS
CBS01	15mm	25mm	15mm	LC 60 series rear
CBS02	10mm	19mm	16.8mm	GQ Patrol CC front

SPECIFICATIONS - LEAF SPRINGS

REPLACEMENT MAIN & SECOND LEAF

PART NUMBER	OME SPRING PART NUMBER	MAIN LEAF PART NUMBER	SECOND LEAF PART NUMBER
FRONT SPRINGS			
CS001F, CS002F	¹ 40 SERIES - OME13, OME131	SL1F/1	SL1F/2
CS003F, CS004F, CS005F	¹ 60 SERIES - OME110, OME111, OME111	SL3F/1	SL3F/2
CS006F, CS007F	¹ 75 SERIES - OME67, OME671	SL6F/1	SL6F/2
CS008FA	¹ HILUX - OME99A	SL8FA/1	SL8FA/2
CS008FB	¹ HILUX - OME99B	SL8FB/1	SL8FB/2
CS009FA	¹ HILUX - OME91A	SL9FA/1	SL9FA/2
CS009FB	¹ HILUX - OME91B	SL9FB/1	SL9FB/2
CS010FA, CS011FA	¹ PATROL M60 - OME3A, OME31A	SL10FA/1	SL10FA/2
CS010FB, CS011FB	¹ PATROL M60 - OME3B, OME31B	SL10FB/1	SL10FB/2
CS012FA, CS013FA	¹ SUZUKI SIERRA - OMES1A	SL12FA/1	SL12FA/2
CS012FB, CS013FB	¹ SUZUKI SIERRA - OMES1B	SL12FB/1	SL12FB/2
CS014F	¹ JEEP YJ - OMEJ1F	SL14F/1	SL14F/2
REAR SPRINGS			
CS001R, CS002R	¹ 40 SERIES - OME14, OME141	SL1R/1	SL1R/2
CS003R	¹ 45 SERIES - OME201	SL3R/1	SL3R/2
CS004RA, CS005RA	¹ 60 SERIES - OME113A, OME1131A	SL4RA/1	SL4RA/2
CS004RB, CS005RB	¹ 60 SERIES - OME113B, OME1131B	SL4RB/1	SL4RB/2
CS006R, CS007R, CS008R	¹ 75 SERIES - OME39, OME391, OME3911, OME39111	SL6R/1	SL6R/2
CS009R, CS010R	¹ HILUX - OME17, OME171, OME1711	SL9R/1	SL9R/2
CS011R, CS012R	¹ PATROL M60 - OME4, OME41	SL11R/1	SL11R/2
¹ CS013R, ¹ CS014R, ¹ CS015R	¹ 78/79 SERIES - OME49, OME491, OME492, OME493	SL13R/1	SL13R/2
CS016RA	¹ PATROL Y60, Y61 CAB CHASSIS - OME61A, OME611A	SL16RA/1	SL16RA/2
CS016RB	¹ PATROL Y60, Y61 CAB CHASSIS - OME61B, OME611B	SL16RB/1	SL16RB/2
CS017RA	¹ HJ60 - OME221A	SL17RA/1	SL17RA/2
CS017RB	¹ HJ60 - OME221B	SL17RB/1	SL17RB/2
CS018R, CS019R, CS020R, CS021R	¹ HILUX - OME180, OME18, OME181, OME1811	SL18R/1	SL18R/2
CS022R, CS023R	¹ TRITON / PAJERO - OME22, OME222	SL22R/1	SL22R/2
CS062R, CS063R	¹ ISUZU / RODEO 2003 - OMEROD4, OMEROD5	SL24R/1	SL24R/2
CS026R, CS027R	¹ MAZDA / FORD UTE - OME26, OME261	SL26R/1	SL26R/2
CS028R, CS029R	¹ ISUZU / RODEO - OMEROD1, OMEROD11, OMEROD111	SL28R/1	SL28R/2
CS030R, CS031R, CS032R	¹ NAVARA D21, D22 - OMENN1, OMENN11, OMENN2	SL30R/1	SL30R/2
CS033RA	JEEP XJ - 75mm	SL33RA/1	D22XL
CS033RB	JEEP XJ - 75mm	SL33RB/1	D22XL
CS034RA, CS035RA	¹ JEEP XJ - OMEJC1A, OMEJC2A	SL34RA/1	SL34RA/2
CS034RB, CS035RB	¹ JEEP XJ - OMEJC1B, OMEJC2B	SL34RB/1	SL34RB/2
CS036R, CS037R	¹ JEEP YJ - OMEJ1R, OMEJ2R	SL36R/1	SL36R/2
CS038R, CS039R	¹ SUZUKI SIERRA - OMES2, OMES21	SL38R/1	SL38R/2
¹ CS043R, ¹ CS044R, ¹ CS045R, ¹ CS071R	HILUX 2005 TO 2015	SL43R/1	SL43R/2
¹ CS049R, CS056R, CS060R	RANGER / BT-50 12/2006 TO 2011	SL49R/1	SL49R/2
CS053R, CS054R	TRITON ML & MN 2006 TO 2015	SL22R/1	SL53R/2
CS062R	COLORADO, DMAX 2008 TO 2011, RODEO 2003 TO 2008	SL62R/1	SL62R/2
CS063R	COLORADO, DMAX 2008 TO 2011, RODEO 2003 TO 2008	SL62R/1	SL63R/2
CS064R, CS065R	AMAROK 2010 ON	SL64R/1	SL64R/2
¹ CS066R	78/79 SERIES	SL13R/1	SL66R/2
¹ CS068R, ¹ CS069R	RANGER 2011 TO MID 2022 / BT-50 2011 TO 2020	SL49R/1	SL49R/2
CS150R, CS151R	NAVARA D40 / EQUATOR (US Market Only)	SL150R/1	D31XL

1. When remaining stock is exhausted no further product will be available.

SPECIFICATIONS - LEAF SPRINGS

U BOLTS

OE spring stack height must be compared to OME spring before final

U Bolt selection as OE spring stack heights may vary from model to model.

PART NO.	A LEG LENGTH mm	B LEG CENTRE mm	C THREAD DIA mm	D THREAD LENGTH mm	THREAD PITCH	E TOP TYPE	REC. TORQUE Lbs.ft.	REC. TORQUE Nm
OMEU51	210	85	14	70	1.5	SQUARE	93	126
OMEU52	200	76	14	75	1.5	FLAT	93	126
OMEU53	168	75	14	70	1.5	SQUARE	93	126
OMEU53A	185	75	14	65	1.5	SQUARE	93	126
OMEU53B	200	75	14	70	1.5	SQUARE	93	126
OMEU54	175	85	12	70	1.25	ROUND	58	79
OMEU55	218	97	14	70	1.5	SQUARE	93	126
OMEU56	100	75	12	50	1.25	SQUARE	58	79
OMEU57	190	88	12	70	1.25	ROUND	58	79
OMEU58	210	110	14	75	1.5	ROUND	93	126
OMEU58B	242	110	14	75	1.5	ROUND	93	126
OMEU59A	197	97	14	75	1.5	ROUND	93	126
OMEU59B	225	97	14	75	1.5	ROUND	93	126
OMEU59C	240	97	14	75	1.5	ROUND	93	126
OMEU59D	197	97	14	90	1.5	ROUND	93	126
OMEU60	150	81	11	70	1.27	ROUND	45	61
OMEU61	147	87	10	60	1.25	ROUND	34	45
OMEU61B	160	87	10	70	1.25	ROUND	34	45
OMEU62	145	73	10	70	1.25	ROUND	34	45
OMEU63	190	74	12	50	1.25	SQUARE	58	79
OMEU64	260	125	14	90	1.5	ROUND	93	126
OMEU65	215	97	14	75	1.5	ROUND	93	126
OMEU66	190	103	14	60	1.5	ROUND	93	126
OMEU66A	210	103	14	60	1.5	ROUND	93	126
OMEU66B	230	102	14	60	1.5	ROUND	93	126
OMEU67	350	107	16	75	2.0	ROUND	145	197
OMEU68	275	107	16	75	2.0	ROUND	145	197
OMEU69	235	95	14	65	2.0	ROUND	93	126
OMEU69A	260	95	14	65	2.0	ROUND	93	126
OMEU70	205	95	14	55	2.0	SQUARE	93	126
OMEU70A	230	95	14	55	2.0	SQUARE	93	126
OMEU71	150	82	12	60	1.5	SQUARE	58	79
OMEU72	200	97	14	90	1.5	ROUND	93	126
OMEU73	125	91	10	40	1.25	ROUND	34	79
OMEU76	170	84	12	50	1.5	SQUARE	58	197
OMEU77	325	97	16	110	2.0	SEMI ROUND	145	197
OMEU78	410	97	16	110	2.0	SEMI ROUND	145	197
OMEU79	295	107	16	110	2.0	ROUND	145	197
OMEU80	380	107	16	110	2.0	ROUND	145	126
OMEU81	180	80	14	50	1.5	SQUARE	93	126
OMEU82	200	80	14	50	1.5	SQUARE	93	126
OMEU83	220	80	14	50	1.5	SQUARE	93	126

U BOLTS

OE spring stack height must be compared to OME spring before final U Bolt selection as OE spring stack heights may vary from model to model.

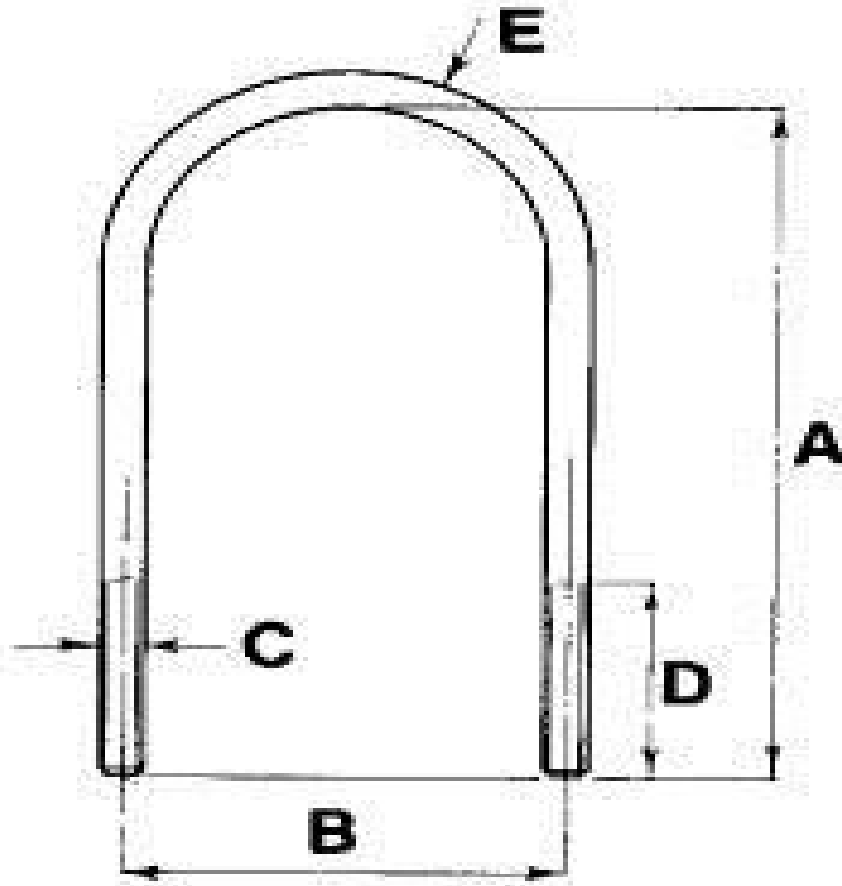

SPECIFICATIONS - LEAF SPRINGS

REPLACEMENT CENTRE BOLTS

Centre Bolt Part No.	Dimension Details						Spring Part No.
	Head Diameter A	Head Depth B	Shank Length C	Shank Diameter D	Thread Length E	Thread	
UCB1	17	10	90	9.5	50	3/8 UNF	CS011R, 12R
UCB2	15	15	90	9.5	50	3/8 UNF	CS004RA/B, 17RA/B
UCB3	14	11	70	9.5	50	3/8 UNF	CS003F, 4F, 5F
UCB4	14	8	110	9.5	50	3/8 UNF	CS003R, 6R, 7R, 8R
UCB5	14	8	70	9.5	50	3/8 UNF	CS006F, 07F, 10FA/B, 11FA/B, 22R, 23R, 40R, 41R, 42R, 53R, 54R, 100R
UCB6	14	8	80	7.9	50	5/16 UNF	CS009R, 10R, 18R, 19R, 20R, 21R
UCB7	14	5	55	7.9	35	5/16 UNF	CS008FA/B, 9FA/B, 12FA/B, 13FA/B, 38R, 39R
UCB8	12	9	75	7.9	50	5/16 UNF	CS001F, 2F, 1R, 2R, 33RA/B, 34RA/B, 35RA/B
UCB09	13	10	55	7.9	40	5/16 UNF	CS014F, 36R, 37R
UCB10	14	8	120	9.5	40	3/8 UNF	CS008R, 48R, ¹ EL081R, ¹ 82R, ¹ 84R, ¹ 85R, 93R, 94R, 115R, 116R
UCB11	17	10	115	9.5	40	3/8 UNF	CS016RA/B
UCB12	11	8	70	7.9	40	5/16 UNF	CS028R
UCB13	14	6	70	9.5	40	3/8 UNF	CS030R, 31R, 32R
UCB14	14	6	80	9.5	40	3/8 UNF	CS030R, 31R, 32R, ¹ 43R, 43R-15, ¹ 44R, ¹ 45R, 46RA/B, ¹ 71R
UCB15	11.5	9	72	7.9	30	5/16 UNF	¹ CS024R, ¹ 25R, 62R, 63R
UCB16	11	8	80	7.9	40	5/16 UNF	CS028R, 29R
UCB17	14	8	90	9.5	50	3/8 UNF	¹ CS013R, ¹ 14R, ¹ 15R, 26R, 27R, ¹ 47R, 57R, 58R, 64R, 65R, ¹ EL095R, ¹ 96R, 101R
UCB18	16	8	50	10	30	M10	¹ CS015F, 18F
UCB19	14	8	95	10	45	M10	CS018R, ¹ 49R, ¹ 50R, ¹ 51R, 56R, 60R, 150R, 151R, ¹ EL013R, ¹ 14R, ¹ 15R, 43R, 44R, 45R, ¹ 49R, ¹ 66R, ¹ 68R, ¹ 69R, 71R, ¹ 72R, ¹ 73R, ¹ 74R, ¹ 79R, ¹ 80R, ¹ 83R, ¹ 86R, ¹ 87R, ¹ 88R, ¹ 89R, ¹ 90R, ¹ 91R, 92R, ¹ 102R, ¹ 103R, ¹ 104R, 105R, 106R, 107R, 108R, 109R, 110R, 113R, 114R, 117R, 118R, 119R, 123R, 124R, 125R, 126R, 127R, 128R
UCB20	16	8	62	10	45	M10	CS018F
UCB21	14	8	180	10	50	M10	EL077R With Overload Leaf

1. When remaining stock is exhausted no further product will be available.

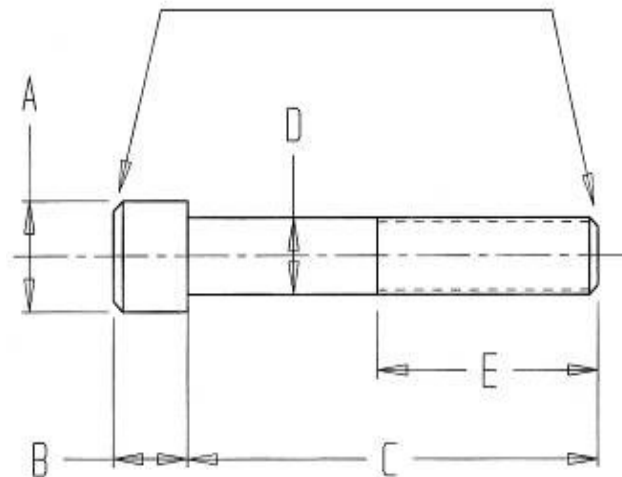

SPECIFICATIONS - LEAF SPRINGS

LEAF SPRINGS

Part No.	OME Part No.	Stack Height (mm)	No. of Leaves	Eye Dia. mm		Weight (kg)	Primary Free Camber mm	Spring Rate	
				Front	Rear			lbf / in	N / mm
CS001F	¹ OME13	48.0	8	35.0	35.0	23.0	165	350	61.3
CS001R	¹ OME14	43.0	5 + 1	35.0	35.0	21.5	225	300 / 450	52.5 / 79
CS002F	¹ OME131	54.0	9	35.0	35.0	27.0	165	398	69.8
CS002R	¹ OME141	49.0	6 + 1	35.0	35.0	25.6	225	357 / 496	62.5 / 87
CS003F	¹ OME110	30.0	5	35.0	35.0	15.5	200	220	38.5
CS003R	¹ OME201	81.0	6 + 3	35.0	35.0	45.4	235	510 / 710	90 / 125
CS004F	¹ OME11	36.0	6	35.0	35.0	17.7	196	257	45
CS004RA	¹ OME113A	58.0	6 + 2	35.0	35.0	31.6	250	268 / 570	47.0 / 100
CS004RB	¹ OME113B	58.0	6 + 2	35.0	35.0	31.6	230	268 / 570	47.0 / 100
CS005F	¹ OME111	42.0	7	35.0	35.0	21.5	196	305	53.5
CS005RA	¹ OME1131A	64.0	7 + 2	35.0	35.0	36.0	250	314 / 617	55 / 108
CS005RB	¹ OME1131B	64.0	7 + 2	35.0	35.0	36.0	230	314 / 617	55 / 108
CS006F	¹ OME67	43.0	7	35.0	35.0	21.6	220	302	53
CS006R	¹ OME391	82.0	7 + 3	40.0	40.0	46.8	240	388 / 610	68 / 107
CS007F	¹ OME671	49.0	8	35.0	35.0	25.5	220	348	61
CS007R	¹ OME3911	89.0	8 + 3	40.0	40.0	52.2	240	455 / 600	80 / 105
CS008FA	¹ OME99A	32.5	5	30.0	30.0	14.8	170	208	36.5
CS008FB	¹ OME99B	32.5	5	30.0	30.0	14.8	150	208	36.5
CS008R	¹ OME39111	96.0	9 + 3	40.0	40.0	59.5	240	500 / 656	88 / 115
CS009FA	¹ OME91A	39.0	6	30.0	30.0	18.4	170	254	44.5
CS009FB	¹ OME91B	39.0	6	30.0	30.0	18.4	150	254	44.5
CS009R	¹ OME17	48.0	4 + 2	30.0	30.0	20.0	230	217 / 388	38.0 / 68.0
CS010FA	¹ OME3A	43.0	7	32.5	32.5	18.9	215	283	49.6
CS010FB	¹ OME3B	43.0	7	32.5	32.5	18.9	200	283	49.6
CS010R	¹ OME171	54.5	5 + 2	30.0	30.0	24.2	230	285 / 445	50.0 / 78.0
CS011FA	¹ OME31A	49.0	8	32.5	32.5	22.3	215	343	60
CS011FB	¹ OME31B	49.0	8	32.5	32.5	22.3	200	343	60
CS011R	¹ OME4	56.0	8	32.5	32.5	26.8	275	211	37
CS012FA	¹ OMES1A	24.4	4	30.0	40.0	8.1	125	207	36.3
CS012FB	¹ OMES1B	24.4	4	30.0	40.0	8.1	110	207	36.3
CS012R	¹ OME41	63.0	9	32.5	32.5	30.2	275	240	42
CS013FA	N/A	30.0	5	30.0	40.0	10.4	125	247	27.9
CS013FB	N/A	30.0	5	30.0	40.0	10.4	110	247	27.9
¹ CS013R	¹ OME491	68.0	5 + 2	40.0	40.0	47.9	268	279 / 548	52 / 96
CS014F	¹ OMEJ1F	26.0	4	31.4	37.6	11.0	210	148	26
¹ +CS014R	¹ +OME492	68.0	5 + 2	40.0	40.0	47.9	268	279 / 548	52 / 96
¹ CS015F	N/A	52.0	6	52.0	42.0	33.0	190	369	65
¹ +CS015R	¹ +OME493	76.0	6 + 2	40.0	40.0	51.5	268	325 / 680	57 / 119
CS016F	N/A	56.0	8	32.7	40.0	27.0	229	337	59
CS016RA	¹ OME611A	82.0	7 + 3	40.0	40.0	50.8	250	325 / 585	57 / 103
CS016RB	¹ OME611B	82.0	7 + 3	40.0	40.0	50.8	235	325 / 585	57 / 103
CS017RA	¹ OME221A	48.0	8	35.0	35.0	25.5	250	255	44.7
CS017RB	¹ OME221B	48.0	8	35.0	35.0	25.5	230	255	44.7
CS018F	N/A	58.0	7	51.5	41.5	37.7	202	431	75.5
*CS018R	¹ *OME180	52.5	3 + 3	39.0	30.0	25.0	215	125 / 485	22 / 85
CS019R	¹ OME18	52.5	3 + 3	39.0	30.0	27.3	235	125 / 485	22 / 85
CS020R	¹ OME181	59.0	4 + 3	39.5	30.0	30.6	235	160 / 540	28 / 95

Free Camber is measured from top of eye (not centre line) to main leaf at centre bolt. Allow 3mm tolerance either side.

Where two spring rates are listed for one part number the spring is progressive.

* These springs have a 20mm lower 2nd Stage than other springs in the series.

+ These springs have a 20mm higher 2nd stage than other springs in this series.

1. When remaining stock is exhausted no further product will be available.

cont.

SPECIFICATIONS - LEAF SPRINGS

LEAF SPRINGS

Part No.	OME Part No.	Stack Height (mm)	No. of Leaves	Eye Dia. mm		Weight (kg)	Primary Free Camber mm	Spring Rate	
				Front	Rear			lbf / in	N / mm
CS021R	¹ OME1811	65.5	5 + 3	39.0	30.0	31.0	235	274 / 571	48 / 100
CS022R	¹ OME22	41.0	5 + 1	31.5	27.5	22.0	195	194 / 388	34.0 / 68.0
+CS023R	¹ +OME222	58.0	6 + 2	31.5	27.5	29.5	195	230 / 570	41 / 100
¹ CS024R	¹ OMEROD4	54.0	4 + 2	39.0	30.0	22.0	181	205 / 450	36 / 79
CS026R	¹ OME26	59.0	4 + 3	32.7	32.7	26.3	164	177 / 616	31 / 108
CS027R	¹ OME261	65.5	5 + 3	32.7	32.7	30.1	164	217 / 662	38 / 116
CS028R	¹ OMEROD11	48.0	4 + 2	39.0	30.0	22.5	250	170 / 457	30 / 80
+CS029R	¹ +OMEROD111	60.5	4 + 3	39.0	30.0	25.4	250	216 / 616	38 / 108
CS030R	¹ OMENN1	52.5	3 + 3	40.0	32.5	22.1	170	126 / 531	22 / 93
CS031R	¹ OMENN11	59.0	4 + 3	40.0	32.5	25.5	170	165 / 571	29 / 100
*CS032R	¹ *OMENN2	52.5	3 + 3	40.0	32.5	22.1	170	126 / 411	22 / 72
CS033RA	N/A	43.5	5 + 1	62.0	43.5	22.4	263	168 / 256	29.4 / 44.9
CS033RB	N/A	43.5	5 + 1	62.0	43.5	224.0	243	168 / 256	29.4 / 44.9
CS034RA	¹ OMEJC1A	32.5	5	62.0	43.5	18.2	230	148	26
CS034RB	¹ OMEJC1B	32.5	5	62.0	43.5	18.2	205	148	26
CS035RA	¹ OMEJC2A	37.0	4 + 1	62.0	43.5	20.9	235	137 / 257	24 / 45
CS035RB	¹ OMEJC2B	37.0	4 + 1	62.0	43.5	20.9	210	137 / 257	24 / 45
CS036R	¹ OMEJ1R	32.5	5	37.5	31.5	13.7	205	188	33
CS037R	¹ OMEJ2R	32.5	5	37.5	31.5	13.8	185	188	33
CS038R	¹ OMES2	36.0	3 + 2	40.0	30.0	9.8	175	171 / 291	30 / 51
CS039R	¹ OMES21	42.0	4 + 2	40.0	30.0	12.3	175	228 / 348	40 / 61
CS040R	¹ OME19	29.0	3 + 1	31.5	27.5	16.4	211	148 / 245	26 / 43
CS041R	¹ OME191	35.0	4 + 1	31.5	27.5	16.4	211	200 / 296	35 / 52
CS042R	¹ OME36	45.0	4 + 1	46.8	31.0	28.0	210	228 / 310	40 / 55
¹ CS043R	N/A	50.0	4 + 2	40.0	30.0	24.0	194	170 / 340	30 / 60
CS043R-15	N/A	50.0	4 + 2	40.0	30.0	24.0	179	170 / 340	30 / 60
¹ CS044R	N/A	50.0	4 + 2	40.0	30.0	24.0	204	170 / 340	30 / 60
¹ +CS045R	N/A	57.0	5 + 2	40.0	30.0	27.5	204	204 / 361	35.8 / 63.8
CS046RA	¹ OME15A	52.0	5 + 2	40.5	30.0	26.7	222	114 / 194	20 / 34
CS046RB	¹ OME15B	52.0	5 + 2	40.5	30.0	26.7	209	114 / 194	20 / 34
¹ CS047R	N/A	57.0	5 + 2	40.0	40.0	32.4	207	182 / 392	32 / 69
CS048R	N/A	50.0	3 + 2	40.0	40.0	32.5	275	225 / 416	39 / 73
¹ CS049R	N/A	45.0	4 + 1	40.0	32.7	25.0	173	212 / 450	37 / 79
¹ CS051R	N/A	67.0	5 + 2	40.0	33.4	36.25	177	244 / 535	43 / 94
CS053R	N/A	35.0	4 + 1	31.5	27.5	20.3	193	166 / 321	29 / 56
CS054R	N/A	41.0	5 + 1	30.0	27.5	24.3	193	209 / 365	37 / 64
CS055R	N/A	65.0	4 + 2	40.0	40.0	36.5	190	205 / 330	36 / 58
CS056R	N/A	37.0	3 + 1	40.0	32.7	20.0	173	147 / 371	26 / 65
CS057R	N/A	59.0	4 + 2	40.0	40.0	36.6	225	234 / 627	41 / 110
CS058R	N/A	66.0	5 + 2	40.0	40.0	42.8	260	300 / 694	53 / 122
CS059R	N/A	55.0	4 + 1	51.0	43.0	22.9	265	242 / 338	43 / 59
CS060R	N/A	70.0	5 + 2	40.0	32.7	33.12	138	277 / 608	49 / 107
CS061R	N/A	58.0	4 + 2	40.0	32.7	24.90	208	186 / 352	32.7 / 61.7
CS062R	N/A	60.0	5 + 2	39.0	30.0	26.0	223	215 / 459	38 / 80
CS063R	N/A	64.0	5 + 2	39.0	30.0	28.0	226	294 / 610	52 / 107
CS064R	N/A	58.0	4 + 2	60.0	46.0	39.2	266	169 / 445	30 / 78
CS065R	N/A	69.0	5 + 2	60.0	46.0	48.2	266	267 / 582	47 / 102
¹ CS066R	N/A	92.0	8 + 2	40.0	40.0	59.6	266	412 / 679	72 / 119

Free Camber is measured from top of eye (not centre line) to main leaf at centre bolt. Allow 3mm tolerance either side.

Where two spring rates are listed for one part number the spring is progressive.

* These springs have a 20mm lower 2nd Stage than other springs in the series.

+ These springs have a 20mm higher 2nd stage than other springs in this series.

1. When remaining stock is exhausted no further product will be available.

cont.

SPECIFICATIONS - LEAF SPRINGS

LEAF SPRINGS

Part No.	OME Part No.	Stack Height (mm)	No. of Leaves	Eye Dia. mm		Weight (kg)	Primary Free Camber mm	Spring Rate	
				Front	Rear			lbf / in	N / mm
¹ CS068R	N/A	66.0	5 + 2	40.0	32.7	33.1	163	277 / 608	49 / 107
¹ CS069R	N/A	80.0	6 + 2	40.0	32.7	37.0	148	338 / 707	59 / 124
CS070R	N/A	83.0	7 + 2	40.0	40.0	50.0	253	408 / 684	71 / 120
¹ CS071R	N/A	64.0	6 + 2	40.0	30.0	31.1	199	258 / 434	42 / 76
CS150R	N/A	59.0	4 + 2	40.0	33.4	30.9	177	192 / 481	34 / 84
CS151R	N/A	67.0	5 + 2	40.0	33.4	36.25	177	244 / 535	43 / 94
¹ EL013R	¹ CS013R	68.0	5 + 2	40.0	40.0	47.2	253	245 / 510	43 / 90
¹ EL014R	¹ CS014R	68.0	5 + 2	40.0	40.0	47.2	280	245 / 510	43 / 90
¹ EL015R	¹ CS015R	76.0	6 + 2	40.0	40.0	53.9	272	294 / 542	52 / 95
EL043R	¹ *CS043R	50.0	4 + 2	40.0	30.0	22.6	175	170 / 340	30 / 60
EL044R	¹ CS044R	50.0	4 + 2	40.0	30.0	22.6	186	170 / 340	30 / 60
EL045R	¹ CS045R	57.0	5 + 2	40.0	30.0	26.9	206	204 / 361	36 / 63
¹ EL049R	¹ CS049R	44.0	4 + 1	40.0	32.7	24.1	161	218 / 403	38 / 71
¹ EL066R	¹ CS066R	92.0	8 + 2	40.0	40.0	58.2	263	412 / 680	72 / 119
¹ EL068R	¹ CS068R	66.0	5 + 2	40.0	32.7	32.2	155	227 / 608	49 / 107
¹ EL069R	¹ CS069R	74.0	6 + 2	40.0	32.7	36.0	147	338 / 707	59 / 124
EL071R	¹ CS071R	64.0	6 + 2	40.0	30.0	30.5	200	258 / 434	45 / 76
¹ EL072R	N/A	53.0	3 + 2	40.0	30.0	27.8	199	193 / 432	34 / 76
¹ EL073R	N/A	61.0	4 + 2	40.0	30.0	32.7	203	250 / 515	44 / 90
¹ EL074R	N/A	69.0	5 + 2	40.0	30.0	37.5	202	307 / 544	54 / 101
EL077R	N/A	82.3	7 + 1	42.0	42.0	59.6	271	301 / 643	53 / 113
¹ EL079R	N/A	68.0	5 + 2	40.0	40.0	47.2	243	245 / 510	43 / 89
¹ EL080R	N/A	68.0	5 + 2	40.0	40.0	47.2	255	245 / 510	43 / 89
¹ EL081R	N/A	76.0	6 + 2	40.0	40.0	54.0	255	325 / 689	57 / 121
¹ EL082R	N/A	92.0	8 + 2	40.0	40.0	58.2	247	412 / 678	72 / 119
¹ EL083R	N/A	63.0	5 + 2	40.0	32.7	28.1	207	209 / 626	36 / 109
¹ EL084R	N/A	77.0	7 + 2	40.0	32.7	34.5	212	292 / 686	51 / 120
¹ EL085R	N/A	84.0	7 + 2	40.0	32.7	39.2	196	416 / 829	73 / 145
¹ EL086R	N/A	56.0	5 + 2	40.0	27.0	28.2	172	198 / 368	35 / 65
¹ EL087R	N/A	63.0	6 + 2	40.0	27.0	32.5	184	241 / 398	42 / 70
¹ EL088R	N/A	66.0	5 + 2	40.0	27.0	33.3	154	373 / 558	65 / 98
¹ EL089R	N/A	52.0	4 + 2	40.0	30.0	26.0	195	169 / 300	30 / 53
¹ EL090R	N/A	62.0	5 + 2	40.0	30.0	31.9	188	220 / 389	39 / 68
¹ EL091R	N/A	68.0	5 + 2	40.0	30.0	35.5	174	217 / 489	56 / 86
EL092R	N/A	51.0	5+1	40.0	32.7	25.0	207	209 / 505	36.6 / 88.5
EL093R	N/A	65.0	7+1	40.0	32.7	31.1	212	292 / 565	51.2 / 99.0
EL094R	N/A	70.0	7+1	40.0	32.7	35.8	196	416 / 590	72.8 / 103.4
¹ EL095R	N/A	57.0	4+2	40.0	40.0	27.4	210	149 / 482	26.1 / 84.5
¹ EL096R	N/A	64.0	5+2	40.0	40.0	31.9	210	182 / 506	31.9 / 88.6
EL100R	N/A	38.0	3+1	50.0	40.0	20.1	170	167 / 589	29.2 / 68.1
EL101R	N/A	46.0	4+1	50.0	40.0	26.5	182	230 / 430	40.2 / 75.3
¹ EL102R	N/A	56.0	4+1	50.0	32.7	23.7	166	213 / 558	37.4 / 97.8
¹ EL103R	N/A	67.0	5+1	50.0	32.7	28.8	167	277 / 601	48.6 / 105.4
¹ EL104R	N/A	79.0	6+1	50.0	32.7	32.8	165	338 / 722	59.3 / 126.5
EL105R	N/A	53.0	4+1	40.0	30.0	23.6	217	169 / 305	29.6 / 53.5
EL106R	N/A	65.0	5+1	40.0	30.0	29.2	221	220 / 384	38.5 / 67.2
EL107R	N/A	71.0	5+1	40.0	30.0	32.8	202	317 / 501	55.5 / 87.8
EL108R	N/A	48.0	3+1	40.0	30.0	22.7	204	193 / 499	33.8 / 87.5
EL109R	N/A	59.0	4+1	40.0	30.0	27.0	205	250 / 538	43.8 / 94.3

Free Camber is measured from top of eye (not centre line) to main leaf at centre bolt. Allow 3mm tolerance either side.

Where two spring rates are listed for one part number the spring is progressive.

* These springs have a 20mm lower 2nd Stage than other springs in the series.

1. When remaining stock is exhausted no further product will be available.

cont.

SPECIFICATIONS - LEAF SPRINGS

LEAF SPRINGS

Part No.	OME Part No.	Stack Height (mm)	No. of Leaves	Eye Dia. mm		Weight (kg)	Primary Free Camber mm	Spring Rate	
				Front	Rear			lbf / in	N / mm
EL110R	N/A	70.0	5+1	40.0	30.0	31.9	201	307 / 576	53.9 / 100.9
EL111R	N/A	66.0	4+2	40.0	40.0	27.4	175	157 / 482	27.6 / 84.5
EL112R	N/A	76.0	5+2	40.0	40.0	32.0	202	193 / 506	33.7 / 88.6
EL113R	N/A	68.0	5 + 2	40.0	40.0	47.2	243	245 / 510	43 / 89
EL114R	N/A	68.0	5 + 2	40.0	40.0	47.2	255	245 / 510	43 / 89
EL115R	N/A	76.0	6 + 2	40.0	40.0	54.0	255	325 / 689	57 / 121
EL116R	N/A	92.0	8 + 2	40.0	40.0	58.2	247	412 / 678	72 / 119
EL117R	N/A	60.0	5+1	40.0	27.0	25.4	157	198 / 375	34.6 / 65.7
EL118R	N/A	70.0	6+1	40.0	27.0	29.7	166	241 / 405	42.2 / 70.9
EL119R	N/A	69.0	5+1	40.0	27.0	30.2	152	373 / 606	65.3 / 106.2
EL120R	N/A	45.0	3+1	50.0	32.7	19.3	241	150 / 515	26.2 / 90.3
EL121R	N/A	56.0	4+1	50.0	32.7	23.7	231	213 / 558	37.4 / 97.8
EL122RA	N/A	64.0	5+2	40.0	40.0	26.2	204	120 / 283	21.1 / 49.6
EL122RB	N/A	64.0	5+2	40.0	40.0	26.2	189	120 / 283	21.1 / 49.6
EL123R	N/A	48.0	3+1	40.0	30.0	22.7	184	193 / 499	33.8 / 87.5
EL124R	N/A	59.0	4+1	40.0	30.0	27.0	184	250 / 538	43.8 / 94.3
EL125R	N/A	70.0	5+1	40.0	30.0	31.9	180	307 / 576	53.9 / 100.9
EL126R	N/A	56.0	4+1	50.0	32.7	23.7	179	213 / 558	37.4 / 97.8
EL127R	N/A	67.0	5+1	50.0	32.7	28.8	179	277 / 601	48.6 / 105.4
EL128R	N/A	79.0	6+1	50.0	32.7	32.8	173	338 / 722	59.3 / 126.5
EL129R	N/A	53	4+1	40	30	23.7	175	169 / 305	29.6 / 53.5
EL130R	N/A	56	4+1	50	32.7	23.8	192	213 / 558	37.4 / 97.8
EL131R	N/A	67	5+1	50	32.7	28.8	188	277 / 601	48.6 / 105.4
EL132R	N/A	79	6+1	50	32.7	32.8	181	338 / 722	59.3 / 126.5
PB007R	N/A	26	2	40	40	20.1	286	248	43.5
PB008R	N/A	28	2	40	40	21.4	277	327	57.3
PB009R	N/A	39	3	40	40	29.6	268	414	72.6
PB010R	N/A	45	3	40	40	32.6	247	620	108.6

Free Camber is measured from top of eye (not centre line) to main leaf at centre bolt. Allow 3mm tolerance either side.
Where two spring rates are listed for one part number the spring is progressive.

SPECIFICATIONS - COIL SPRINGS

COIL SPRINGS

Spring Number	X5K Steel	Bar Dia. mm	Free Height mm		Number of Turns	Coil weight Kg	Spring Rate		OE Spring Rate Lbs
			A	B			lbf / in	N / mm	
2105 ¹	X	19	475	485	9.0	8.5	350	61	160
2106 ¹	X	21	460	470	8.3	11.3	400 / 440	70 / 77	170
2412	X	17	460	445	8.0	6.1	250	44	200
2413	X	17	485	470	8.0	6.1	250	44	200
2414	X	18	510	495	9.5	8.3	250	44	200
2415	X	19	510	495	7.7	8.5	290	51	180
2416	X	19	535	520	7.7	8.5	290	51	180
2417	X	19.5	560	545	8.3	9.9	290	51	180
2418	X	18	505	515	9.0	7.5	300	52	160
2419	X	18	530	540	9.0	7.5	300	52	160
2420	X	19	555	565	10.75	10.0	300	52	160
2421	X	19	480	490	7.7	8.5	280	49	170
2422	X	19	505	515	7.7	8.5	280	49	170
2423	X	19.5	530	540	8.3	9.9	280	49	170
2500 ¹	X	14.5	385	385	5.4	3.4	155	27	130
2501 ¹	X	15	350	350	7.3	4.3	175	31	130
2502 ¹	X	16	350	350	6.0	4.3	245	43	130
2503 ¹	X	15	342	342	7.0	4.1	185	32	130
2504 ¹	X	14.5	355	355	5.4	3.4	155	27	130
2505 ¹	X	15	330	330	7.3	4.3	175	31	130
2506 ¹	X	15	330	330	5.1	3.4	180	32	130
2507 ¹	X	15	338	338	5.1	3.5	180	32	160
2508 ¹	X	15	315	315	5.6	3.6	180	32	160
2509 ¹	X	17	360	360	5.4	4.7	250	44	200
2510 ¹	X	15	360	360	7.15	4.1	180	32	140
2511 ¹	X	13.5	345	345	6.6	2.8	190	33	160
2512 ¹	X	17.5	305	305	6.25	4.1	500	88	420
2513 ¹	X	14.5	345	345	6.63	3.3	250	44	200
2516 ¹	X	16	270	270	4.7	3.5	260	46	200
2517 ¹	X	16	280	280	4.7	3.5	260	46	200
2518 ¹	X	14.5	325	325	8.6	3.4	340	60	280
2519 ¹	X	15.5	355	355	5.7	4.1	190	33	140
2520 ¹	X	15	360	360	6.6	3.9	180	32	150
2523 ¹	X	16	300	300	8.0	4.1	500	88	440
2524 ¹	X	15	255	255	5.7	2.8	200	35	160
2525 ¹	X	15	340	340	5.75	3.8	215	38	160
2526 ¹	X	14.5	385	385	6.25	3.5	190	33	150
2527 ¹	X	19	385	385	5.0	6.5	240	42	180
2528 ¹	X	16	310	310	5.5	3.5	310	54	180
2529 ¹	X	14.5	375	375	7.51	3.6	230	40	300
2530 ¹	X	16	335	335	7.25	4.2	350	61	190
2531 ¹	X	14	315	315	6.5	3.0	230	40	100
2532 ¹	X	12	310	310	7.75	2.4	140	25	260
2533 ¹	X	16	450	450	11.0	5.3	355	62	280
2534 ¹	X	17	360	360	7.4	5.1	330	58	160
2535 ¹	X	14	370	370	7.5	3.3	200	35	450
2536	X	17	265	260	6.5	3.9	650	114	450
2538	X	17	265	260	6.5	3.9	650	114	150
2539 ¹	X	13.5	345	345	5.9	2.7	180	32	350
2540 ¹	X	16	300	300	7.0	3.7	420	74	540
2601 ¹	X	18	350	350	8.35	5.5	650	114	150
2602 ¹	X	16	392	392	8.22	5.6	180	32	140
2603	X	17	410	410	7.0	6.4	188	33	140
2604	X	17	400	400	6.0	5.5	227	38	680
2605	X	18	315	315	7.75	5.1	730	128	680

1. When remaining stock is exhausted no further product will be available.

cont.

SPECIFICATIONS - COIL SPRINGS

COIL SPRINGS

Spring Number	X5K Steel	Bar Dia. mm	Free Height mm		Number of Turns	Coil weight Kg	Spring Rate		OE Spring Rate Lbs
			A	B			lbf / in	N / mm	
2606	X	18	320	320	7.75	5.1	730	128	680
2607	X	16.5	370	370	9.5	5.3	480	84	450
2608	X	16.5	380	380	9.5	5.3	480	84	450
2609	X	19	440	440	8.0	7.8	390	68	330
2610	X	20	430	430	8.0	8.7	460	81	330
2611	X	18	310	310	7.75	5.1	730	128	680
2612	X	20	415	415	10.99	8.9	740	130	680
2613	X	20	435	435	10.99	8.9	740	130	680
2614	X	20	425	425	10.99	8.9	740	130	680
2615	X	13	510	510	10.0	3.7	120	21	120
2616	X	14	490	490	10.5	4.6	135	24	120
2617	X	15	430	430	7.0	4.1	160	28	100
2618	X	16	435	435	7.75	5.3	175	31	100
2619	X	14	515	515	10.5	4.6	135	24	120
2620	X	15	450	450	9.0	4.5	200	35	120
2621	X	14	520	520	9.55	4.1	150	26	120
2622	X	14.5	375	375	7.0	3.6	210	37	160
2623	X	15	375	375	6.1	3.8	200	35	160
2624	X	15	365	365	6.1	3.8	200	35	160
2625 (12/19 On)	X	16	540	540	9.5	4.3	540	95	460
2625 (To 11/19)	X	17	345	345	8.5	4.8	540	95	460
2626	X	13	500	500	10.0	3.7	120	21	120
2627	X	14	475	475	10.5	4.6	135	24	120
2628	X	14	505	505	10.5	4.6	135	24	120
2629	X	14	505	505	9.55	4.1	150	26	120
2630	X	15	405	405	7.0	4.1	160	28	100
2631	X	17.5	375	375	9.9	5.9	580	102	88
2640 ¹	X	17.5	305	305	7.4	4.5	730	128	670
2641 ¹	X	18	310	310	7.4	4.8	790	139	670
2642	X	14	540	540	10.5	4.6	135	24	120
2643	X	14.5	460	460	9.0	4.2	175	31	100
2700	X	18	420	420	8.75	5.7	625	109	500
2701	X	19	425	425	9.48	6.9	720	126	500
2702	X	18.5	430	430	9.48	6.6	625	109	500
2703	X	19	435	435	9.48	6.9	720	126	500
2704	X	18	410	410	8.8	6.6	625	109	500
2705	X	19	415	415	9.5	6.9	720	126	500
2720	X	18.5	420	410	8.42	8.8	270 / 350	47 / 61	170
2721	X	18.5	440	430	8.42	8.8	270 / 350	47 / 61	170
2722	X	19	440	430	7.2	8.0	275	48	170
2723	X	20	450	440	7.2	8.9	340	59	170
2724	X	21	445	435	7.2	9.8	400	70	170
2725	X	22	445	435	7.71	11.6	440	77	170
2730	X	15.5	315	315	5.4	3.5	240	42	200
2731	X	15.5	300	300	5.0	3.1	280	49	200
2743	X	21	360	360	8.6	8.7	800	140	600
2744	X	18	400	400	9.7	6.5	530	93	480
2745	X	19	390	390	9.7	7.2	670	117	480
2746	X	20	370	370	8.6	7.9	680	119	600
2751	X	15	390	380	6.57	3.9	225	39	200
2752	X	17	440	440	9.0	7.7	175 / 200	31 / 35	200
2754	X	20	435	435	6.9	8.3	420	74	240
2755	X	18	435	435	6.8	6.5	300	52	240
2760	X	15	395	385	9.0	5.2	180 / 250	32 / 44	160
2761	X	15	400	390	7.5	4.4	200	35	160

1. When remaining stock is exhausted no further product will be available.

cont.

SPECIFICATIONS - COIL SPRINGS

COIL SPRINGS

Spring Number	X5K Steel	Bar Dia. mm	Free Height mm		Number of Turns	Coil weight Kg	Spring Rate		OE Spring Rate Lbs
			A	B			lbf / in	N / mm	
2762	X	17.5	420	410	8.6	7.0	300 / 340	52 / 60	170
2763	X	18	420	410	7.8	6.7	360	63	200
2764	X	16	430	420	8.0	5.4	220	39	200
2765 ¹	X	22	410	410	8.0	11.7	540	95	240
2766	X	16	420	420	7.52	5.0	250	44	220
2767	X	16	385	375	6.66	4.5	285	50	200
2768	X	20	560	560	11.0	10.3	450	79	220
2770 ¹	X	16	480	470	10.0	6.5	260	45	160
2776	X	14	410	390	7.0	3.6	160	28	150
2777	X	14.5	395	375	7.24	4.0	180	32	150
2779	X	15.5	385	375	7.29	4.6	225	39	150
2780 ¹	X	18.5	470	460	8.68	9.0	250 / 340	43 / 59	160
2781	X	17	425	415	7.7	5.9	290	51	160
2789	X	16	280	280	7.25	3.9	410	72	380
2790	X	17	378	378	9.35	5.2	500	87	400
2791	X	16	280	280	7.25	3.9	410	72	380
2792	X	14	435	435	9.3	4.1	155	27	130
2793	X	15	350	350	5.2	3.7	165	29	120
2794	X	16	260	255	7.25	4.2	420	73	330
2795	X	16	285	285	6.0	4.0	360	63	330
2796 ¹	X	16	255	250	7.25	4.2	420	73	330
2797	X	13	350	350	10.0	2.7	340	59	300
2798	X	13	400	400	10.2	3.2	210	36	180
2799 ¹	X	16	353	353	5.5	4.5	200	35	150
2802	X	16	445	445	11.31	5.9	320	56	205
2803	X	16	465	465	10.7	5.5	340	59	205
2838	X	18	420	410	7.5	7.7	205 / 290	36 / 51	160
2850	X	16.5	495	505	9.0	6.2	220	38	160
2850J	X	17	515	525	9.9	7.3	220	38	160
2851	X	16	475	485	8.18	5.3	220	38	160
2853	X	16.5	485	485	10.13	6.2	275	48	160
2856	X	16	465	465	10.0	5.3	230	40	210
2859	X	16	470	470	9.25	5.3	275	48	210
2860	X	17	480	490	6.88	6.0	220	38	170
2861	X	16	480	490	10.4	6.8	170 / 250	30 / 44	160
2862	X	17	460	470	9.0	7.8	170 / 260	30 / 46	160
2863	X	18	480	490	7.0	6.9	250	43	170
2863J	X	18.5	505	515	7.7	9.2	265	46	170
2864	X	19	480	490	7.2	7.8	320	56	170
2865	X	17	460	460	6.88	6.0	220	38	170
2866	X	18	465	465	9.0	8.8	240 / 300	42 / 52	170
2868	X	20	480	490	7.15	8.8	360	63	170
2869	X	16.5	380	380	9.8	4.7	590	103	500
2870	X	14	370	355	8.5	3.6	220	38	160
2871	X	16	410	400	7.25	4.9	220	38	160
2872	X	14	400	400	9.0	3.9	190	33	160
2873	X	16	455	455	8.25	5.6	200	35	160
2874	X	15	408	408	9.0	4.5	220	38	160
2875	X	17	440	440	8.3	6.4	240	42	170
2876	X	14	390	375	8.5	3.6	200	35	160
2880	X	16	365	365	10.2	4.7	500	87	490
2881	X	16	375	375	10.2	4.7	500	87	490
2882	X	16.5	395	395	11.1	5.3	500	87	490
2883	X	16.5	375	375	9.75	4.7	590	103	500
2884	X	16.5	390	390	9.75	4.7	590	103	500

1. When remaining stock is exhausted no further product will be available.

cont.

SPECIFICATIONS - COIL SPRINGS

COIL SPRINGS

Spring Number	X5K Steel	Bar Dia. mm	Free Height mm		Number of Turns	Coil weight Kg	Spring Rate		OE Spring Rate Lbs
			A	B			lbf / in	N / mm	
2885 (01/09 On)	X	17	395	395	10.75	4.7	590	103	500
2885	X	16.5	395	395	9.75	4.7	590	103	500
2886	X	17.5	402	402	10.6	5.9	660	115	590
2887 (01/09 On)	X	17	400	400	10.75	4.7	590	103	500
2887	X	16.5	400	400	9.75	4.7	590	103	500
2888 (01/09 On)	X	17	405	405	10.75	4.7	590	103	500
2888	X	16.5	405	405	9.75	4.7	590	103	500
2889	X	16.5	400	400	6.21	4.6	260	45	150
2890	X	14.5	440	430	9.7	5.0	190	33	150
2891	X	15.5	425	415	9.5	5.6	210	37	150
2892	X	17	400	390	8.9	6.4	260 / 380	67	150
2895	X	16.5	390	390	6.21	4.6	260	45	150
2895E	X	17	375	375	6.75	5.4	260	45	150
2896	X	18	390	390	6.75	6.1	318	56	150
2897	X	19	390	390	6.75	6.9	387	68	150
2898	X	18	400	400	6.75	6.1	318	56	150
2899	X	19	400	400	6.75	6.9	387	68	150
2900	X	15	405	395	6.36	4.1	180	32	140
2901	X	16	395	385	6.25	4.6	220	38	140
2902	X	18	340	340	8.35	5.5	650	114	560
2903	X	16	380	380	7.3	5.0	210	37	160
2904	X	15	410	410	6.8	4.2	170	30	140
2905	X	17	313	313	6.0	4.6	360	63	300
2906	X	15	390	380	9.0	5.0	220	38	160
2907 ¹	X	17	370	370	5.25	5.0	213	37	160
2908 ¹	X	16	295	295	7.25	4.2	368	64	300
2910	X	17	400	390	7.5	6.9	150 / 260	26 / 45	160
2911	X	16	400	390	7.5	6.0	140 / 230	24 / 40	160
2912	X	15	420	420	10.8	5.7	180 / 300	31 / 52	160
2913	X	15	390	390	9.3	4.9	180 / 300	31 / 52	160
2914	X	18	330	330	8.1	5.5	650	114	580
2915	X	18	345	345	8.1	5.5	650	114	580
2917	X	21	345	335	7.25	8.4	700 / 900	112 / 158	650
2918	X	22	338	328	7.25	9.3	860 / 1000	151 / 175	650
2919	X	15	430	430	10.8	5.7	200 / 280	35 / 49	160
2920	X	14	430	430	8.0	3.7	190	33	160
2921	X	16	385	385	6.8	5.2	200	35	150
2922	X	14	360	360	6.1	3.3	140	25	120
2923	X	16	395	395	6.8	5.2	200	35	150
2924	X	19	340	340	8.1	6.2	790	138	580
2925	X	16	385	385	10.77	5.2	375	66	320
2926	X	16	392	392	10.77	5.2	375	66	320
2927	X	16	394	394	10.3	5.0	400	70	320
2928	X	16	410	410	6.8	5.3	200	35	150
2929	X	16	420	420	10.8	6.5	240 / 300	42 / 53	180
2930	X	14	475	465	9.8	4.2	162	28	140
2931	X	14	510	500	11.9	5.1	140	25	140
2932	X	14	480	470	11.2	4.8	140	25	140
2933	X	14	495	485	11.2	4.8	140	25	140
2934	X	14	510	500	10.0	4.3	160	28	140
2935	X	14	420	410	9.8	4.1	180	32	140
2936	X	15	420	410	10.0	4.8	220	39	170
2937	X	15	400	400	7.25	4.1	220	39	170
2938	X	18	400	390	7.5	7.7	205 / 290	36 / 51	160
2940	X	14	380	370	8.6	3.7	190	33	140

1. When remaining stock is exhausted no further product will be available.

cont.

SPECIFICATIONS - COIL SPRINGS

COIL SPRINGS

Spring Number	X5K Steel	Bar Dia. mm	Free Height mm		Number of Turns	Coil weight Kg	Spring Rate		OE Spring Rate Lbs
			A	B			lbf / in	N / mm	
2941	X	15	390	375	7.2	4.4	140	25	140
2942	X	15.5	380	365	6.58	4.2	160	28	140
2943	X	15	370	360	8.6	4.3	230	40	150
2944	X	15	395	385	8.0	4.4	190	33	165
2945	X	16	350	340	7.5	4.7	240	42	170
2947	X	16	340	340	5.8	4.4	170	30	150
2948	X	16	340	340	5.56	4.2	200	35	150
2949	X	17	370	355	7.1	5.6	216	38	160
2950	X	16	300	300	8.5	4.0	540	95	420
2951	X	15	290	290	8.5	3.5	440	77	420
2952	X	11	345	345	8.3	1.8	142	25	120
2953	X	16	285	285	8.5	4.1	540	95	420
2954	X	12	340	340	8.5	2.2	180	32	140
2955	X	13	350	350	10.0	3.0	200	35	140
2956	X	16	330	330	8.5	4.2	500	88	420
2959	X	16	310	310	8.5	4.0	540	95	440
2960	X	15	300	300	8.5	3.5	440	77	410
2961	X	13	340	340	10.0	3.0	200	35	150
2962	X	16	320	320	8.5	4.0	540	95	440
2963	X	11.5	350	350	10.0	2.4	146	26	120
2965	X	11.5	365	365	10.0	2.4	146	26	120
2966	X	12	335	315	10.0	2.5	176	31	120
2967	X	12	325	325	9.0	2.4	176	31	120
2968	X	14	370	370	9.35	3.7	210	37	120
2969	X	12	360	360	9.5	2.5	170	30	150
2970	X	17	395	385	6.7	5.2	320	56	160
2971	X	17	405	395	6.66	4.5	320	56	160
2972	X	16	400	385	6.55	4.5	250	44	160
2972E	X	16	404	404	6.55	4.5	250	44	160
2973	X	16	415	400	6.55	4.5	250	44	160
2974	X	16	385	370	6.55	4.5	250	44	160
2974E	X	16	385	385	6.55	4.5	250	44	160
2975	X	16	425	410	7.45	5.0	220	39	160
2976	X	16	440	425	7.2	4.9	220	39	160
2977	X	20	370	370	7.6	7.1	730	128	650
2978	X	20.5	370	370	7.6	7.6	790	138.5	650
2979	X	20.5	375	375	7.6	7.6	790	138.5	650
2980	X	19	490	470	9.0	10.0	250	44	200
2981	X	21	480	460	9.0	12.3	300	53	200
2982	X	19	470	450	9.0	10.0	250	44	200
2983	X	20	480	455	9.0	11.1	300 / 400	44 / 70	200
2984	X	21	480	455	9.0	12.3	360 / 450	63 / 79	200
2985	X	21	480	460	7.0	9.8	470	82	200
2986	X	21	500	500	8.2	10.0	540	94.7	380
2987	X	22	500	500	8.1	11.0	610	107	380
2988	X	22.4	500	500	8.2	11.5	680	119	380
2990	X	18	370	370	8.9	6.3	530	93	440
2991	X	19	365	365	8.9	7.1	630	110	440
2992	X	17	355	345	7.15	5.8	240	42	190
2993	X	18	345	335	6.6	6.0	280	49	190
2994	X	21	335	325	7.25	8.4	700 / 900	123 / 158	600
2995	X	22	350	340	7.25	9.3	860 / 1000	151 / 175	600
2996	X	17.5	370	355	7.1	6.0	250	44	200
2997	X	18	360	360	8.72	5.5	800	140	700
2998	X	18	365	365	8.72	5.5	800	140	700
2999	X	18.5	365	365	8.72	5.8	840	147	700

cont.

SPECIFICATIONS - COIL SPRINGS

COIL SPRINGS

Spring Number	X5K Steel	Bar Dia. mm	Free Height mm		Number of Turns	Coil weight Kg	Spring Rate		OE Spring Rate Lbs
			A	B			lbf / in	N / mm	
3027	X	18.5	325	325	7.6	5.4	800	140	680
3028	X	17	430	420	8.5	6.1	330	58	250
3029	X	17	440	430	8.5	6.1	330	58	250
3030	X	20	435	425	7.5	9.0	270 / 330	47 / 58	190 / 280
3033	X	18	430	420	8.0	7.0	320	56	N/A
3034	X	21	505	485	9.0	12.4	300	52	N/A
3035	X	22	505	485	8.1	12.4	470	82	N/A
3036	X	18	455	445	8.0	7.0	320	56	N/A
3037	X	21	530	510	9.0	12.4	300	52	N/A
3038	X	22	530	510	8.1	12.4	470	82	N/A
3039	X	17	520	530	9.9	7.3	220	38.5	N/A
3040	X	19	505	515	8.3	9.2	250	44	N/A
3043	X	19	530	540	8.3	9.2	250	44	N/A
3046	X	15.5	490	490	9.81	5.4	200	35	N/A
3047	X	14.5	545	545	10.74	5.2	150	26	N/A
3048	X	18	350	350	8.72	5.5	800	140	N/A
3049	X	20	505	515	8.3	10.3	320	56	N/A
3051	X	17	545	555	9.9	7.3	220	38.5	N/A
3052	X	20	530	540	8.3	10.3	320	56	N/A
3056 ¹	X	16.5	360	360	9.75	4.7	590	103	580
3057	X	16.5	365	365	9.75	4.7	590	103	580
3058	X	16.5	370	370	9.75	4.7	590	103	580
3059 ¹	X	15.5	480	480	9.5	5.0	250	44	220
3060	XT	21	360	360	8.0	7.9	880	154	750
3061	X	16.5	450	450	9.85	6.2	250 / 300	44 / 52.5	N/A
3062	X	15.5	450	440	9.5	6.0	200	35	N/A
3063	X	16	450	440	9.5	6.5	225	39.4	N/A
3064	X	17	520	520	9.53	8.1	175 / 200	30.6 / 35	N/A
3065	X	19	515	515	9.3	10.0	270 / 330	47 / 58	N/A
3066	X	21	500	500	9.66	12.9	370 / 430	65 / 75	N/A
3067	X	22.4	470	460	8.30	13.4	350 / 650	61 / 114	N/A
3070 ¹	X	15.5	445	445	9.50	5.0	250	44	220
3071 ¹	X	15.5	485	485	9.50	5.0	250	44	220
3072 ¹	X	15.5	495	495	9.50	5.0	250	44	220
3073 ¹	X	15.5	460	460	9.50	5.0	250	44	220
3074	XT	20	385	385	8.00	7.0	750	131	750
3075	XT	21.5	580	580	11.95	13.1	520	91	N/A
3076	XT	21.5	605	605	11.95	13.1	520	91	N/A
3077 ¹	X	17	400	390	8.50	6.1	330	58	N/A
3078 ¹	XT	20	405	395	7.50	8.5	270 / 330	47 / 58	N/A
3079	X	17.5	310	310	7.75	4.7	690	121	N/A
3080	X	18	315	315	7.75	5.0	745	130	N/A
3085 ¹	X	15.5	515	510	10.75	6.0	250	44	220
3086 ¹	X	16	505	500	10.75	6.0	250	44	220
3087	X	15	420	420	8.50	4.5	220	38.5	220
3088	X	15.5	440	440	10.25	5.9	200 / 260	35 / 46	200
3089	X	16	445	445	10.25	6.3	240 / 300	42 / 53	200
3090	X	16.5	450	450	10.25	6.7	260 / 330	46 / 58	200
3091	X	15	435	435	8.18	4.1	220	38.5	220
3092	X	15.5	425	425	8.18	4.4	260	46	220
3093	X	16.5	430	430	8.13	5.0	320	56	220
3094	X	18	330	330	8.72	5.5	800	140	700
3095	X	16	445	445	8.50	5.8	180/260	32/46	210
3096	X	17	440	440	8.50	6.5	220/320	39/56	210
3097	X	18	440	440	8.50	7.4	280/380	49/67	210

1. When remaining stock is exhausted no further product will be available.

cont.

SPECIFICATIONS - COIL SPRINGS

COIL SPRINGS

Spring Number	X5K Steel	Bar Dia. mm	Free Height mm		Number of Turns	Coil weight Kg	Spring Rate		OE Spring Rate Lbs
			A	B			lbf / in	N / mm	
3098	X	19	440	440	8.50	8.3	350/450	61/84	210
3099	X	16.75	390	390	10.00	5.4	500	87.5	440
3100	X	16.75	395	395	10.00	5.4	500	87.5	440
3101	X	16.75	400	400	10.00	5.4	500	87.5	440
3102	X	18.5	305	305	7.75	5.4	800	140	760
3103	X	18.5	310	310	7.75	5.4	800	140	760
3104	X	18.5	315	315	7.75	5.4	800	140	760
3105	X	18.5	320	320	7.75	5.4	800	140	760
3106	X	18	470	470	8.75	8.1	240-330	42-58	180-220
3107	X	18.5	490	490	8.75	8.6	260-350	46-61	180-220
3108	X	18	320	320	8.1	5.5	650	114	N/A
3109	X	18	340	340	8.1	5.5	650	114	N/A
3110	X	19.5	400	400	8.0	7.8	562-740	98-129	N/A
3111	X	20.3	410	410	8.0	8.5	700-840	122-147	N/A
3112	X	22.5	380	380	6.93	9.1	975	170	N/A
3113	X	17.5	435	435	9.85	7.0	300-400	52-70	N/A
3114	X	16.5	385	385	9.75	4.7	590	103	500
3115	X	18	325	325	7.75	5.0	745	130	N/A
3116	X	18	330	330	7.75	5.0	745	130	N/A
3118	X	15.5	430	430	10.5	5.0	325	57	N/A
3119	X	15.5	440	440	10.5	5.0	325	57	N/A
3120	X	15.5	450	450	10.5	5.0	325	57	N/A
3121	X	15.5	460	460	10.5	5.0	325	57	N/A
3132	X	18	325	325	7.75	5.1	730	128	680
3133	X	14	470	460	10.5	4.7	140	24.5	N/A
3134	X	14	490	480	10.5	4.7	140	24.5	N/A
3135	X	14	515	505	10.5	4.7	140	24.5	N/A
3136	X	15	425	415	7.9	4.5	160	28	N/A
3137	X	15.5	430	420	7.8	4.8	175	31	N/A
3138	X	16.5	430	420	8.0	5.6	225	39	N/A
3139	X	17	430	420	7.8	5.8	260	45.5	N/A
3140	X	17.5	375	375	10.0	5.8	605	106	N/A
3141	X	17.5	390	390	10.0	5.8	605	106	N/A
3142	X	17.5	400	400	10.0	5.8	605	106	N/A
3143	X	17.5	405	405	10.0	5.8	605	106	N/A
3144	X	12	370	370	9.46	2.6	146	25.5	N/A
3145	X	12	380	380	9.46	2.6	146	25.5	N/A
3146	X	11	350	340	8.7	2.0	125	22	N/A
3153	X	13.5	450	440	9.32	4.7	140	24.5	N/A
3154	X	14	475	465	10.5	4.7	140	24.5	N/A
3155	X	14	485	475	10.5	4.7	140	24.5	N/A
3156	X	14	51	500	10.50	4.7	140	24.5	N/A
3157	X	15	390	380	7.09	4.0	175	30.7	N/A
3158	X	16	390	380	7.24	4.7	225	39.4	N/A
3159	X	16.5	390	380	7.08	4.9	260	45.5	N/A
3160	X	13.5	430	420	9.32	3.9	140	24.5	N/A
3161	X	14.5	385	375	7.11	3.8	160	28.0	N/A
3162	X	14.75	515	505	10.50	5.2	170	30.0	N/A
3163	X	18	415	415	10.47	6.5	600	105.0	N/A
3164	X	18	425	425	10.47	6.5	600	105.0	N/A
3165	X	18	430	430	10.47	6.5	600	105.0	N/A
3167	X	16.5	515	505	10.22	6.8	220	38.5	N/A
3168	X	17.5	515	505	9.83	7.4	280	49.0	N/A
3169	X	18.5	515	505	9.83	8.2	340	59.5	N/A
3175	X	14.5	515	505	10.50	5.0	160	28.0	N/A

cont.

SPECIFICATIONS - COIL SPRINGS

COIL SPRINGS

Spring Number	X5K Steel	Bar Dia. mm	Free Height mm		Number of Turns	Coil weight Kg	Spring Rate		OE Spring Rate Lbs
			A	B			lbf / in	N / mm	
3176	X	17.5	385	385	9.35	5.0	660	115.5	N/A
3177	X	17.5	395	395	10.18	5.8	660	115.5	N/A
3178 ¹	X	17.5	400	400	10.18	5.8	660	115.5	N/A
3179 ¹	X	17.5	405	405	10.18	5.8	660	115.5	N/A
3181	X	17	405	405	9.0	5.5	460	80.5	N/A
3182	X	15.5	450	450	9.0	5.1	215	38.0	N/A
3183	X	15.75	480	480	9.49	5.6	215	38.0	N/A
3185	X	19	450	420	7.20	8.0	275	48.0	N/A
3186	X	20	460	430	7.20	9.0	340	59.5	N/A
3187	X	21	455	425	7.20	9.9	400	70.0	N/A
3188	X	21	455	425	6.72	9.0	440	77.0	N/A
3189	X	11.5	370	370	9.55	2.4	122	21.0	N/A
3190	X	17.5	390	390	9.35	5.0	660	115.5	N/A
3191	X	16.5	465	465	9.37	6.8	180 / 260	32.46	N/A
3192	X	17.5	460	460	9.37	7.7	220 / 320	39 / 56	N/A
3193	X	18.5	460	460	9.37	8.7	280 / 380	49 / 67	N/A
3194	X	19.5	460	460	9.37	9.7	350 / 480	61 / 84	N/A
3195	X	14.5	400	400	6.79	4.5	110 / 230	19 / 40	N/A
3196	X	16.5	310	310	7.75	4.0	560 / 710	98 / 124	N/A
3198	X	15.75	452	452	10.50	5.2	332 / 400	58 / 70	N/A
3199	X	16.25	450	450	10.30	5.6	363 / 435	64 / 76	N/A
3200	X	16.5	447	447	10.00	5.5	393 / 472	69 / 83	N/A
3204	X	14.25	525	525	16.00	6.5	239 / 287	42 / 50	N/A
3205	X	14.75	530	530	15.80	7.4	288 / 345	50 / 60	N/A
3206	X	15.25	535	535	15.80	8.2	336 / 403	59 / 71	N/A
3207	X	18.5	415	415	9.29	6.6	605	106	N/A
3208	X	18.5	425	425	9.29	6.6	605	106	N/A
3209	X	18.5	430	430	9.29	6.6	605	106	N/A
3210	X	18.5	435	435	9.29	6.6	605	106	N/A
3211	X	18.5	405	405	9.29	6.4	605	106	N/A
3212	X	17.5	500	500	8.75	7.5	210 / 300	37 / 53	N/A
3213	X	18	490	190	8.75	8.0	240 / 330	42 / 58	N/A
3214	X	18.5	505	505	8.75	8.5	260 / 350	46 / 61	N/A
3215	X	18	406	406	9.30	5.9	625	109.5	N/A
3216	X	18.5	410	410	10.00	6.8	625	109.5	N/A
3217	X	18	415	415	10.00	6.4	625	109.5	N/A
3218	X	18	420	420	10.00	6.5	625	109.5	N/A
3219	X	17.5	495	495	9.00	8.4	175 / 220	30.7 / 38.5	N/A
3220	X	20	450	450	7.20	9.6	340	59.6	N/A
3221	X	21	445	445	7.20	9.6	400	70.1	N/A
3222	X	21	445	445	6.72	8.9	440	77.1	N/A
3224	X	18	400	400	9.30	5.9	630	110.4	N/A
4000	X	17	385	385	9.00	5.0	588	103	N/A
4001	X	17	370	370	9.00	5.0	588	103	N/A
4002	X	17	390	390	9.00	5.0	588	103	N/A
4003	X	16	370	370	8.50	4.2	497	87	N/A
4004	X	17	395	395	9.00	5.0	588	103	N/A
4005	X	17	375	375	9.00	5.0	588	103	N/A
4006	X	16	360	360	8.50	4.2	497	87	N/A
4007	X	17	380	380	9.00	5.0	588	103	N/A
4008	X	18.5	425	425	9.70	6.9	622	109	N/A

1. When remaining stock is exhausted no further product will be available.

cont.

SPECIFICATIONS - COIL SPRINGS

COIL SPRINGS

Spring Number	X5K Steel	Bar Dia. mm	Free Height mm		Number of Turns	Coil weight Kg	Spring Rate		OE Spring Rate Lbs
			A	B			lbf / in	N / mm	
4009	X	17	385	385	8.75	4.9	605	106	N/A
4010	X	18.5	415	415	9.70	6.9	622	109	N/A
4011	X	16.5	375	375	9.00	4.8	479	84	N/A
4013	X	18	355	355	8.45	5.3	799	140	N/A
4014	X	20	365	365	8.20	7.5	731	128	N/A
4015	X	17	370	370	8.80	4.8	605	106	N/A
4016	X	16.5	385	385	8.70	4.7	499	87.5	N/A
4017	X	19	410	410	9.45	7.1	742	130	N/A
4018	X	17	360	360	9.00	5.0	588	103	N/A
4019	X	18.5	405	405	9.70	6.9	622	109	N/A
4022	X	18.5	385	385	9.70	6.9	622	109	N/A
4023	X	18.5	390	390	9.70	6.9	622	109	N/A
4024	X	18	410	410	8.81	6.0	605	106	N/A
4025	X	18	345	345	8.45	5.3	799	140	N/A
4026	X	17	365	365	9.00	5.0	588	103	N/A
4028	X	18	400	400	8.80	6.0	605	106	N/A
4029	X	15.5	425	425	10.30	5.0	325	57	N/A
4030	X	15.5	435	435	10.30	5.0	325	57	N/A
4031	X	16.5	370	370	9.00	4.8	479	84	N/A
4032	X	16	365	365	9.00	4.8	479	84	N/A
4033	X	18	315	315	7.80	5.2	742	130	N/A
4034	X	17.5	310	310	7.63	4.8	691	121	N/A
4035	X	18	415	415	10.20	6.6	599	105	N/A
4036	X	15.75	400	400	9.40	4.5	400	70	N/A
2GQ02A	X	18	465	465	9.0	9.0	200	35.0	180
2GQ02AM	X	18	505	490	8.7	8.7	220 / 240	39 / 42	180
2GQ02B	X	19	445	445	9.0	10.0	250 / 280	44 / 49	180
2GQ02C	X	18	480	465	9.0	9.0	200	35	180
2GQ02CM	X	17	485	470	9.0	7.9	170 / 190	30 / 33	180
2GQ02D	X	18	480	480	9.0	9.0	200	35	180
2GQ02G	X	19	475	460	9.0	10.0	220 / 350	39 / 61	180
2GQ02J	X	20	480	465	9.0	11.1	280 / 310	49 / 54	180
2GQ02LP	X	19	475	445	9.0	10.0	250 / 280	44 / 49	180

X5K MICRO-ALLOYED SPRING STEEL is a new generation high strength spring steel grade designed to withstand higher operating stresses with superior resistance to sag and improved toughness and corrosion fatigue properties. These properties are enhanced by with lower Carbon than conventional spring steel grades. additions of Silicon, Chromium, Vanadium Nickel along with lower Carbon than conventional spring steel grades.

Where two spring rates are listed for one part number the spring is progressive.

SPECIFICATIONS - SHOCK ABSORBERS

BP-51 - SPECS / PRELOAD & DAMPER SETTINGS

Part Number	Open Length (mm)	Closed Length (mm)	Adjuster settings:		Adjuster settings:		Adjuster settings:		Strut Preload: Bar, Winch & Accessories	Strut Preload: Bar Only	Strut Preload: No accessories
			Front: Bar & Winch		Front: Bar Only		Front: No Accessories				
			Rear: 400kg+		Rear: 200kg - 400kg		Rear: 0kg - 200kg				
			Comp	Rebound	Comp	Rebound	Comp	Rebound			
D=DIESEL / P=PETROL in mm											
BP5160001L	593mm	373mm	6-10	6-10	4-8	4-8	2-6	2-6	-	-	-
BP5160001R	593mm	373mm	6-10	6-10	4-8	4-8	2-6	2-6	-	-	-
BP5160002	607.5mm	385mm	4-8	6-10	2-6	6-10	0-4	4-8	-	-	-
BP5160003	606mm	388mm	4-8	6-10	2-6	6-10	0-4	4-8	-	-	-
BP5160004L	623mm	392mm	6-10	6-10	3-6	3-6	0-3	0-3	-	-	-
BP5160004R	623mm	392mm	6-10	6-10	3-6	3-6	0-3	0-3	-	-	-
BP5160005	484mm	300mm	6-8	7-9	5-7	6-8	0-4	4-8	-	-	-
BP5160006	651mm	405mm	6-10	6-10	3-6	3-6	0-3	0-3	-	-	-
BP5160007	544mm	330mm	6-8	7-9	5-7	6-8	0-4	4-8	-	-	-
BP5160008	711mm	435mm	6-10	6-10	3-6	3-6	0-3	0-3	-	-	-
BP5160009	516mm	319mm	4-8	6-10	2-6	5-9	0-4	4-8	-	-	-
BP5160010	645mm	400mm	4-8	6-10	2-6	2-6	0-4	0-4	-	-	-
BP5160011L	625mm	390mm	4-8	6-10	2-6	6-10	0-4	4-8	-	-	-
BP5160011R	625mm	390mm	4-8	6-10	2-6	6-10	0-4	4-8	-	-	-
BP5160012	606mm	364mm	4-8	6-10	2-6	5-9	0-4	4-8	-	-	-
BP5160013	611mm	388mm	4-8	6-10	2-6	4-8	4-8	6-10	-	-	-
BP5160014	656mm	389mm	4-8	6-10	2-6	5-9	0-4	4-8	-	-	-
BP5160015	661mm	413mm	4-8	6-10	2-6	4-8	4-8	6-10	-	-	-
BP5160016	558mm	362mm	6-10	6-10	3-6	3-6	0-3	0-3	-	-	-
BP5160017	685mm	420mm	4-8	6-10	2-6	2-6	0-4	0-4	-	-	-
BP5160018L	645mm	400mm	4-8	6-10	2-6	0-6	0-4	0-4	-	-	-
BP5160018R	645mm	400mm	4-8	6-10	2-6	0-6	0-4	0-4	-	-	-
BP5160019	554mm	358mm	4-8	6-10	2-6	2-6	0-4	0-4	-	-	-
BP5160020L	651mm	405mm	4-8	6-10	2-6	6-10	0-4	4-8	-	-	-
BP5160020R	651mm	405mm	4-8	6-10	2-6	6-10	0-4	4-8	-	-	-
BP5160021	628mm	395mm	4-8	4-8	2-6	2-6	0-4	0-4	-	-	-
BP5160022	678mm	420mm	4-8	4-8	2-6	2-6	0-4	0-4	-	-	-
BP5160023	686mm	428mm	4-8	6-10	2-6	4-8	0-4	2-6	-	-	-
BP5160024L	593mm	373mm	6-10	6-10	4-8	4-8	2-6	2-6	-	-	-
BP5160024R	593mm	373mm	6-10	6-10	4-8	4-8	2-6	2-6	-	-	-
BP5160025	607.5mm	385mm	4-8	6-10	2-6	6-10	0-4	4-8	-	-	-
BP5160026	606mm	388mm	4-8	6-10	2-6	6-10	0-4	4-8	-	-	-
BP5160027L	623mm	392mm	6-10	6-10	3-6	3-6	0-3	0-3	-	-	-
BP5160027R	623mm	392mm	6-10	6-10	3-6	3-6	0-3	0-3	-	-	-
BP5160028	645mm	400mm	4-8	6-10	2-6	2-6	0-4	0-4	-	-	-
BP5160029	685mm	420mm	4-8	6-10	2-6	2-6	0-4	0-4	-	-	-
BP5160030	686mm	428mm	4-8	6-10	2-6	4-8	0-4	2-6	-	-	-
BP5160031	578mm	370mm	4-8	4-8	2-6	2-6	0-4	0-4	-	-	-
BP5160032	616mm	393mm	4-8	6-10	2-6	4-8	0-4	2-6	-	-	-
BP5160033	649mm	416mm	4-8	6-10	2-6	5-9	0-4	4-8	-	-	-
BP5160034L	686mm	428mm	4-8	6-10	2-6	4-8	0-4	2-6	-	-	-
BP5160034R	686mm	428mm	4-8	6-10	2-6	4-8	0-4	2-6	-	-	-
BP5160035	606mm	364mm	4-8	6-10	2-6	5-9	0-4	4-8	-	-	-
BP5160036	600mm	364mm	4-8	6-10	2-6	4-8	0-4	0-4	-	-	-
BP5160037L	623mm	392mm	6-10	6-10	3-6	3-6	0-3	0-3	-	-	-
BP5160037R	623mm	392mm	6-10	6-10	3-6	3-6	0-3	0-3	-	-	-
BP5160038	484mm	300mm	6-8	7-9	5-7	6-8	0-4	4-8	-	-	-
BP5160039	651mm	405mm	6-10	6-10	3-6	3-6	0-3	0-3	-	-	-
BP5160040	544mm	330mm	6-8	7-9	5-7	6-8	0-4	4-8	-	-	-
BP5160041	711mm	435mm	6-10	6-10	3-6	3-6	0-3	0-3	-	-	-
BP5160042	516mm	319mm	4-8	6-10	2-6	5-9	0-4	4-8	-	-	-
BP5160043	606mm	364mm	4-8	6-10	2-6	5-9	0-4	4-8	-	-	-
BP5160044	656mm	389mm	4-8	6-10	2-6	5-9	0-4	4-8	-	-	-
BP5160045	606mm	364mm	4-8	6-10	2-6	5-9	0-4	4-8	-	-	-
BP5160048	558mm	362mm	6-10	6-10	3-6	3-6	0-3	0-3	-	-	-
BP5160049L	631mm	400mm	6-10	6-10	3-6	3-6	0-3	0-3	-	-	-

Note: BP-51 Parts Matrix available on ARB Online under resources tab

SPECIFICATIONS - SHOCK ABSORBERS

BP-51 - SPECS / PRELOAD & DAMPER SETTINGS

Part Number	Open Length (mm)	Closed Length (mm)	Adjuster settings:		Adjuster settings:		Adjuster settings:		Strut Preload: Bar, Winch & Accessories	Strut Preload: Bar Only	Strut Preload: No accessories		
			Front: Bar & Winch		Front: Bar Only		Front: No Accessories						
			Rear: 400kg+		Rear: 200-400kg		Rear: 0-200kg		D=DIESEL / P=PETROL in mm				
			Comp	Rebound	Comp	Rebound	Comp	Rebound					
BP5160049R	631mm	400mm	6-10	6-10	3-6	3-6	0-3	0-3	-	-	-		
BP5160050	618mm	393mm	6-10	6-10	3-6	3-6	0-3	0-3	-	-	-		
BP5160051L	645mm	400mm	4-8	6-10	2-6	0-6	0-4	0-4	-	-	-		
BP5160051R	645mm	400mm	4-8	6-10	2-6	0-6	0-4	0-4	-	-	-		
BP5160052	685mm	420mm	4-8	6-10	2-6	2-6	0-4	0-4	-	-	-		
BP5160053	606mm	388mm	4-8	6-10	2-6	6-10	0-4	4-8	-	-	-		
BP5160055L	663mm	413mm	6-10	6-10	3-6	3-6	0-3	0-3	-	-	-		
BP5160055R	663mm	413mm	6-10	6-10	3-6	3-6	0-3	0-3	-	-	-		
BP5160056	609mm	391mm	6-10	6-10	3-6	3-6	0-3	0-3	-	-	-		
BP5160057	645mm	400mm	4-8	6-10	2-6	2-6	0-4	0-4	-	-	-		
BP5160058	554mm	358mm	4-8	6-10	2-6	2-6	-	-	-	-	-		
BP5160061	664mm	416mm	7-10	6-10	3-7	4-8	0-4	2-6	-	-	-		
BP5160062	664mm	416mm	7-10	6-10	5-8	6-10	-	-	-	-	-		
BP5160064L	583mm	399mm	6-10	6-10	3-6	3-6	0-3	0-3	-	-	-		
BP5160064R	583mm	399mm	6-10	6-10	3-6	3-6	0-3	0-3	-	-	-		
BP5190001L	545mm	439mm	4-8	6-10	2-6	5-9	0-4	4-8	D-20 P-15	D-15 P-10	D-10 P-5		
BP5190001R	545mm	439mm	4-8	6-10	2-6	5-9	0-4	4-8	D-20 P-15	D-15 P-10	D-10 P-5		
BP5190002L	545mm	439mm	4-8	6-10	2-6	5-9	0-4	4-8	20	15	10		
BP5190002R	545mm	439mm	4-8	6-10	2-6	5-9	0-4	4-8	20	15	10		
BP5190003L	605mm	449mm	4-8	7-10	2-6	6-10	0-4	6-10	D-20 P-10	D-15 P-5	D-10 P-0		
BP5190003R	605mm	449mm	4-8	7-10	2-6	6-10	0-4	6-10	D-20 P-10	D-15 P-5	D-10 P-0		
BP5190004L	545mm	439mm	4-8	6-10	2-6	5-9	0-4	4-8	20	15	10		
BP5190004R	545mm	439mm	4-8	6-10	2-6	5-9	0-4	4-8	20	15	10		
BP5190005L	505mm	339mm	4-8	6-10	2-6	5-9	0-4	4-8	25	20	15		
BP5190005R	505mm	339mm	4-8	6-10	2-6	5-9	0-4	4-8	25	20	15		
BP5190006L	545mm	439mm	4-8	6-10	2-6	5-9	0-4	4-8	20	15	10		
BP5190006R	545mm	439mm	4-8	6-10	2-6	5-9	0-4	4-8	20	15	10		
BP5190007L	540mm	439mm	4-8	6-10	2-6	5-9	0-4	4-8	D-20 P-15	D-15 P-10	D-10 P-5		
BP5190007R	540mm	439mm	4-8	6-10	2-6	5-9	0-4	4-8	D-20 P-15	D-15 P-10	D-10 P-5		
BP5190008L	470mm	339mm	4-8	7-10	4-8	6-10	2-6	4-8	20	15	5		
BP5190008R	470mm	339mm	4-8	7-10	4-8	6-10	2-6	4-8	20	15	5		
BP5190009L	516.5mm	411mm	4-8	6-10	2-6	5-9	0-4	4-8	25-20	15	5		
BP5190009R	516.5mm	411mm	4-8	6-10	2-6	5-9	0-4	4-8	25-20	15	5		
BP5190010L	625mm	397.5mm	4-8	7-10	2-6	6-10	0-4	6-10	25	20	10		
BP5190010R	625mm	397.5mm	4-8	7-10	2-6	6-10	0-4	6-10	25	20	10		
BP5190011L	509mm	403mm	4-8	6-10	2-6	5-9	0-4	4-8	25-20	15	10		
BP5190011R	509mm	403mm	4-8	6-10	2-6	5-9	0-4	4-8	25-20	15	10		
BP5190012L	498mm	392mm	4-8	6-10	2-6	5-9	0-4	4-8	25-20	15	5		
BP5190012R	498mm	392mm	4-8	6-10	2-6	5-9	0-4	4-8	25-20	15	5		
BP5190013L	503mm	402mm	4-8	6-10	2-6	5-9	0-4	4-8	15	10-5	5-0		
BP5190013R	503mm	402mm	4-8	6-10	2-6	5-9	0-4	4-8	15	10-5	5-0		
BP5190014L	521mm	415mm	4-8	6-10	2-6	5-9	0-4	4-8	20-15	10	5		
BP5190014R	521mm	415mm	4-8	6-10	2-6	5-9	0-4	4-8	20-15	10	5		
BP5190015L	569mm	437mm	4-8	6-10	2-6	5-9	0-4	4-8	20-25	15	5		
BP5190015R	569mm	437mm	4-8	6-10	2-6	5-9	0-4	4-8	20-25	15	5		
BP5190016L	429.5mm	334mm	4-8	6-10	2-6	5-9	0-4	4-8	20-10	10-5	5-0		
BP5190016R	429.5mm	334mm	4-8	6-10	2-6	5-9	0-4	4-8	20-10	10-5	5-0		
BP5190019L	615mm	469mm	0-6	4-7	2-8	6-10	5-10	7-10	D-25 P-20	D-15 P-10	D-5 P-0		
BP5190019R	615mm	469mm	0-6	4-7	2-8	6-10	5-10	7-10	D-25 P-20	D-15 P-10	D-5 P-0		

Note: BP-51 Parts Matrix available on ARB Online under resources tab

SPECIFICATIONS - SHOCK ABSORBERS

BP-51 - SPARE PARTS

Part Number	Upper Mount Replacement Kit	Lower Mount Replacement Kit	Stone Guard	Stone Guard Mounting Kit	Damper Mounting Kit	Valve Cap
BP5160001L	VM50010014SP	VM50010015SP	VD31020240SP	VD31000003SP	VM80010002	VD30020003SP
BP5160001R	VM50010014SP	VM50010015SP	VD31010240SP	VD31000003SP	VM80010002	VD30020003SP
BP5160002	VM50010005SP	VM50010016SP	VD31010240SP	VD31000003SP	VM80010010	VD30020003SP
BP5160003	VM50010006SP	VM50010016SP	VD31010260SP	VD31000003SP	VM80010004/5	VD30020003SP
BP5160004L	VM50010017SP	VM50010010SP	VD31020260SP	VD31000003SP	VM80010012	VD30020003SP
BP5160004R	VM50010017SP	VM50010010SP	VD31010260SP	VD31000003SP	VM80010012	VD30020003SP
BP5160005	VM50010011SP	VM50010011SP	-	-	VM80010022	VD30020003SP
BP5160006	VM50010018SP	VM50010019SP	VD31020260SP	VD31000003SP	VM80010023	VD30020003SP
BP5160007	VM50010011SP	VM50010011SP	-	-	VM80010022	VD30020003SP
BP5160008	VM50010018SP	VM50010019SP	VD31020280SP	VD31000003SP	VM80010023	VD30020003SP
BP5160009	VM50010005SP	VM50010005SP	-	-	VM80010006	VD30020003SP
BP5160010	VM50010020SP	VM50010015SP	VD31020260SP	VD31000003SP	VD80010007	VD30020003SP
BP5160011L	VM50010005SP	VM50010010SP	VD31020260SP	VD31000003SP	VM80010017	VD30020003SP
BP5160011R	VM50010005SP	VM50010010SP	VD31010260SP	VD31000003SP	VM80010017	VD30020003SP
BP5160012	VM50010005SP	VM50010005SP	-	-	VM80010025	VD30020003SP
BP5160013	VM50010005SP	VM50010021SP	VD31010240SP	VD31000003SP	VM80010026	VD30020003SP
BP5160014	VM50010005SP	VM50010005SP	-	-	VM80010025	VD30020003SP
BP5160015	VM50010005SP	VM50010021SP	VD31010260SP	VD31000003SP	VM80010026	VD30020003SP
BP5160016	VD50020002SP	VD50020002SP	VD31020220SP	VD31000003SP	VM80010031	VD30020003SP
BP5160017	VM50010020SP	VM50010015SP	VD31020280SP	VD31000003SP	VD80010007	VD30020003SP
BP5160018L	VM50010014SP	VM50010022SP	VD31020260SP	VD31000003SP	VM80010019	VD30020003SP
BP5160018R	VM50010014SP	VM50010022SP	VD31010260SP	VD31000003SP	VM80010019	VD30020003SP
BP5160019	VM50010012SP	VM50010013SP	VD31020220SP	VD31000003SP	VM80010021	VD30020003SP
BP5160020L	VM50010006SP	VM50010010SP	VD31010260SP	VD31000003SP	VM80010035	VD30020003SP
BP5160020R	VM50010006SP	VM50010010SP	VD31020260SP	VD31000003SP	VM80010035	VD30020003SP
BP5160021	VM50010008SP	VM50010010SP	-	-	VM80010014	VD30020003SP
BP5160022	VM50010008SP	VM50010010SP	-	-	VM80010014	VD30020003SP
BP5160023	VM50010009SP	VM50010010SP	VD31030280SP	VD31000004SP/ 5SP	VM80010015	VD30020003SP
BP5160024L	VM50010014SP	VM50010015SP	VD31020240SP	VD31000003SP	VM80010002	VD30020003SP
BP5160024R	VM50010014SP	VM50010015SP	VD31010240SP	VD31000003SP	VM80010002	VD30020003SP
BP5160025	VM50010005SP	VM50010016SP	VD31010240SP	VD31000003SP	VM80010010	VD30020003SP
BP5160026	VM50010006SP	VM50010016SP	VD31010260SP	VD31000003SP	VM80010004/5	VD30020003SP
BP5160027L	VM50010017SP	VM50010010SP	VD31020260SP	VD31000003SP	VM80010012	VD30020003SP
BP5160027R	VM50010017SP	VM50010010SP	VD31010260SP	VD31000003SP	VM80010012	VD30020003SP
BP5160028	VM50010020SP	VM50010015SP	VD31020260SP	VD31000003SP	VM80010007	VD30020003SP
BP5160029	VM50010020SP	VM50010015SP	VD31020280SP	VD31000003SP	VM80010007	VD30020003SP
BP5160030	VM50010009SP	VM50010010SP	VD31030280SP	VD31000004SP/ 5SP	VM800010015	VD30020003SP
BP5160031	VM50010008SP	VM50010010SP	-	-	VM80010014	VD30020003SP
BP5160032	VM50010009SP	VM50010010SP	VD31030240SP	VD31000004SP/ 5SP	VM80010024	VD30020003SP
BP5160033	VM50010025SP	VM50010010SP	-	-	VM80010038	VD30020003SP
BP5160034L	VM50010025SP	VM50010010SP	VD31020280SP	VD31000005SP	VM80010039	VD30020003SP
BP5160034R	VM50010025SP	VM50010010SP	VD31020280SP	VD31000004SP	VM80010039	VD30020003SP
BP5160035	VM50010005SP	VM50010023SP	-	-	VM80010036	VD30020003SP
BP5160036	VM50010005SP	VM50010024SP	VD31010260SP	VD31000003SP	VM80010037	VD30020003SP
BP5160037L	VM50010017SP	VM50010010SP	VD31020260SP	VD31000003SP	VM80010012	VD30020003SP
BP5160037R	VM50010017SP	VM50010010SP	VD31020260SP	VD31000003SP	VM80010012	VD30020003SP
BP5160038	VM50010011SP	VM50010011SP	-	-	VM80010022	VD30020003SP
BP5160039	VM50010018SP	VM50010019SP	VD31020260SP	VD31000003SP	VM80010041	VD30020003SP
BP5160040	VM50010011SP	VM50010011SP	-	-	VM80010022	VD30020003SP
BP5160041	VM50010018SP	VM50010019SP	VD31020280SP	VD31000003SP	VM80010041	VD30020003SP
BP5160042	VM50010005SP	VM50010005SP	-	-	VM80010006	VD30020003SP
BP5160043	VM50010005SP	VM50010005SP	-	-	VM80010025	VD30020003SP
BP5160044	VM50010005SP	VM50010005SP	-	-	VM80010025	VD30020003SP
BP5160045	VM50010005SP	VM50010023SP	-	-	VM80010036	VD30020003SP
BP5160048	VD50020002SP	VD50020002SP	VD31020220SP	VD31000003SP	VM80010031	VD30020003SP

Note: BP-51 Parts Matrix available on ARB Online under resources tab

SPECIFICATIONS - SHOCK ABSORBERS

BP-51 - SPARE PARTS

BP-51	Upper Mount Replacement Kit	Lower Mount Replacement Kit	Stone Guard	Stone Guard Mounting Kit	Damper Mounting Kit	Valve Cap
BP5160049L	VM50010010SP	VM50010010SP	VD31020260SP	VD31000003SP	VM80010042	VD30020003SP
BP5160049R	VM50010010SP	VM50010010SP	VD31010260SP	VD31000003SP	VM80010042	VD30020003SP
BP5160050	VD50020002SP	VD50020002SP	VD31020240SP	VD31000003SP	VM80010045	VD30020003SP
BP5160051L	VD50010032SP	VD50010045SP	VD31020260SP	VD31000003SP	VM90010019	VD30020003SP
BP5160051R	VD50010032SP	VD50010045SP	VD31010260SP	VD31000003SP	VM90010019	VD30020003SP
BP5160052	VD50010032SP	VD50010045SP	VD31020280SP	VD31000003SP	VM80010007	VD30020003SP
BP5160053	VM50010006SP	VD50010045SP	VD31010240SP	VD31000003SP	VM80010005	VD30020003SP
BP5160055L	VD50020001SP	VD50020001SP	VD31020260SP	VD31000003SP	VM80010052	VD30020003SP
BP5160055R	VD50020001SP	VD50020001SP	VD31020260SP	VD31000003SP	VM80010052	VD30020003SP
BP5160056	VD50010040SP	VD50010040SP	VD31010220SP	VD31000003SP	VM80010048	VD30020003SP
BP5160057	VD50010032SP	VD50010045SP	VD31020260SP	VD31000003SP	VM80010007	VD30020003SP
BP5160058	VM50010012SP	VD50010045SP	VD31020220SP	VD31000003SP	VM80010021	VD30020003SP
BP5160061	VM50010006SP	VD50010045SP	VD31010260SP	VD31000003SP	VM80010055	VD30020003SP
BP5160062	VM50010006SP	VD50010045SP	VD31010260SP	VD31000003SP	VM80010055	VD30020003SP
BP5160064L	VD50050003SP	VD50050003SP	VD31010240SP	VD31000003SP	VM90010065	VD30020003SP
BP5160064R	VD50050003SP	VD50050003SP	VD31010240SP	VD31000003SP	VM90010065	VD30020003SP
BP5190001L	VD10010019SP	VD10010019SP	-	-	VM80010001	VD30020003SP
BP5190001R	VD10010019SP	VD10010019SP	-	-	VM80010001	VD30020003SP
BP5190002L	VD10010019SP	VD10010019SP	-	-	VM80010008/ 9	VD30020003SP
BP5190002R	VD10010019SP	VD10010019SP	-	-	VM80010008/ 9	VD30020003SP
BP5190003L	VD10010019SP	VD10010019SP	-	-	VM80010003	VD30020003SP
BP5190003R	VD10010019SP	VD10010019SP	-	-	VM80010003	VD30020003SP
BP5190004L	VD10010019SP	VD10010019SP	-	-	VM80010009	VD30020003SP
BP5190004R	VD10010019SP	VD10010019SP	-	-	VM80010009	VD30020003SP
BP5190005L	VD10010019SP	VD10010019SP	-	-	VM80010011	VD30020003SP
BP5190005R	VD10010019SP	VD10010019SP	-	-	VM80010011	VD30020003SP
BP5190006L	VD10010019SP	VD10010019SP	-	-	VM80010016	VD30020003SP
BP5190006R	VD10010019SP	VD10010019SP	-	-	VM80010016	VD30020003SP
BP5190007L	VD10010019SP	VD10010019SP	-	-	VM80010018	VD30020003SP
BP5190007R	VD10010019SP	VD10010019SP	-	-	VM80010018	VD30020003SP
BP5190008L	VD10010019SP	VD10010019SP	-	-	VM80010020	VD30020003SP
BP5190008R	VD10010019SP	VD10010019SP	-	-	VM80010020	VD30020003SP
BP5190009L	VD10010019SP	VD10010019SP	-	-	VM80010030	VD30020003SP
BP5190009R	VD10010019SP	VD10010019SP	-	-	VM80010030	VD30020003SP
BP5190010L	VD10010019SP	VD10010022SP	-	-	VM80010034	VD30020003SP
BP5190010R	VD10010019SP	VD10010022SP	-	-	VM80010034	VD30020003SP
BP5190011L	VD10010019SP	VD10010022SP	-	-	VM80010027	VD30020003SP
BP5190011R	VD10010019SP	VD10010022SP	-	-	VM80010027	VD30020003SP
BP5190012L	VD10010019SP	VD10010022SP	-	-	VM80010040	VD30020003SP
BP5190012R	VD10010019SP	VD10010022SP	-	-	VM80010040	VD30020003SP
BP5190013L	VD10010019SP	VD10010022SP	-	-	VM80010043	VD30020003SP
BP5190013R	VD10010019SP	VD10010022SP	-	-	VM80010043	VD30020003SP
BP5190014L	VD10010019SP	VD10010019SP	-	-	VM80010044	VD30020003SP
BP5190014R	VD10010019SP	VD10010019SP	-	-	VM80010044	VD30020003SP
BP5190015L	VD10010019SP	VD10010022SP	-	-	VM80010053	VD30020003SP
BP5190015R	VD10010019SP	VD10010022SP	-	-	VM80010053	VD30020003SP
BP5190016L	VD10010019SP	VD10010019SP	-	-	VM80010047	VD30020003SP
BP5190016R	VD10010019SP	VD10010019SP	-	-	VM80010047	VD30020003SP
BP5190019L	VD10010019SP	VD10010025SP	-	-	VM80010054	VD30020003SP
BP5190019R	VD10010019SP	VD10010025SP	-	-	VM80010054	VD30020003SP

Note: BP-51 Parts Matrix available on ARB Online under resources tab

SPECIFICATIONS - SHOCK ABSORBERS

MT-64

Part Number	Open Length (mm)	Closed Length (mm)	Type Upper	UPPER MOUNT BUSH KIT	Type Lower	LOWER MOUNT BUSH KIT	Shaft Guard Replacement (inc.clips)
MT64601001L	624	406	EYE	VD50010032SP	EYE	VD50010045SP	VD31020240SP
MT64601001R	624	406	EYE	VD50010032SP	EYE	VD50010045SP	VD31010240SP
MT64601002L	629	411	EYE	VD50010032SP	EYE	VD50010045SP	VD31020240SP
MT64601002R	629	411	EYE	VD50010032SP	EYE	VD50010045SP	VD31010240SP
MT64601003	515	326	PIN	VM50010005SP	PIN	VM50010005SP	N/A
MT64601005	619	401	EYE	VD50010032SP	EYE	VD50010045SP	VD31020240SP
MT64601006	619	401	EYE	VD50010032SP	EYE	VD50010045SP	VD31020240SP
MT64601008	664	421	EYE	VD50010032SP	EYE	VD50010045SP	VD31020280SP
MT64601009	598	390	PIN	VM50010005SP	EYE	VD50010045SP	VD31010260SP
MT64601010	598	390	PIN	VM50010005SP	EYE	VD50010045SP	VD31010260SP
MT64601011	598	390	PIN	VM50010005SP	EYE	VD50010045SP	VD31010260SP
MT64601013L	600	392	PIN	VM50010005SP	EYE	VD50020001SP	VD31020240SP
MT64601013R	600	392	PIN	VM50010005SP	EYE	VD50020001SP	VD31010240SP
MT64602003L	647	419	EYE	VD50020002SP	EYE	VD50020002SP	VD31020240SP
MT64602003R	647	419	EYE	VD50020002SP	EYE	VD50020002SP	VD31010240SP
MT64602004L	647	419	EYE	VD50020002SP	EYE	VD50020002SP	VD31020240SP
MT64602004R	647	419	EYE	VD50020002SP	EYE	VD50020002SP	VD31010240SP
MT64901001	566	-	PIN	N/A	EYE	VD50050004SP	N/A
MT64901007	566	-	PIN	N/A	EYE	VD50050004SP	N/A
MT64902001	550	385	PIN	N/A	EYE	VD50050009SP	N/A
MT64902002	550	384	PIN	N/A	EYE	VD50050009SP	N/A

SPECIFICATIONS - SHOCK ABSORBERS

NITROCHARGER PLUS

Part Number	Open Length (mm)	Closed Length (mm)	Upper Mount Kit	Lower Mount Kit	Dirt Shield	Spring Seat	Spring Seat Spacer Kit / Snap Ring	SMP Type		Other SMP Kit
								Top/Bottom		
63000	445	301	NPSMP001	NPSMP044	NPDS001	#N/A	#N/A	2		N/A
63001	445	301	NPSMP001	NPSMP044	NPDS001	#N/A	#N/A	2		N/A
63002	615	371	NPSMP001	NPSMP045	NPDS002	#N/A	#N/A	2		N/A
63003	615	371	NPSMP001	NPSMP045	NPDS002	#N/A	#N/A	2		N/A
63004	579	355	NPSMP002	NPSMP045	NPDS003	#N/A	#N/A	1		N/A
63005	579	355	NPSMP002	NPSMP045	NPDS003	#N/A	#N/A	1		N/A
63006	597	369	NPSMP003 (1 kit req)		NPDS002	#N/A	#N/A			N/A
63007	597	369	NPSMP003 (1 kit req)		NPDS002	#N/A	#N/A			N/A
63008	525	320	NPSMP002	NPSMP002	NPDS003	#N/A	#N/A	1	1	N/A
63009	577	348	NPSMP004	NPSMP005	NPDS004	#N/A	#N/A	3		N/A
63010	648	399	NPSMP005	NPSMP005	NPDS004	#N/A	#N/A			N/A
63011	648	399	NPSMP005	NPSMP005	NPDS004	#N/A	#N/A			N/A
63012	497	302	NPSMP006	NPSMP006	NPDS001	#N/A	#N/A	4	4	N/A
63013	497	302	NPSMP006	NPSMP006	NPDS001	#N/A	#N/A	4	4	N/A
63013L	552	328	NPSMP006	NPSMP006	NPDS005	#N/A	#N/A	4	4	N/A
63014	654	399	NPSMP005	NPSMP015	NPDS003	#N/A	#N/A			N/A
63015	654	399	NPSMP005	NPSMP015	NPDS003	#N/A	#N/A			N/A
63015L	714	429	NPSMP005	NPSMP015	NPDS003	#N/A	#N/A			N/A
63016	368	258	NPSMP007	NPSMP007	NPDS006	#N/A	#N/A			N/A
63017	556	347	NPSMP008	NPSMP046	NPDS004	#N/A	#N/A			N/A
63018	616	356	NPSMP002	NPSMP002	NPDS003	#N/A	#N/A	1	1	N/A
63018L	665	390	NPSMP002	NPSMP002	NPDS002	#N/A	#N/A	1	1	N/A
63019	570	348	NPSMP009	NPSMP007	NPDS007	#N/A	#N/A	5		N/A
63020	624	377	NPSMP002	NPSMP005	NPDS003	#N/A	#N/A	1		N/A
63020L	671	397	NPSMP002	NPSMP005	NPDS002	#N/A	#N/A	1		N/A
63021	317	219	NPSMP004	NPSMP032	NPDS008	#N/A	#N/A	3		N/A
63022	357	236	NPSMP004	NPSMP022	NPDS006	#N/A	#N/A	3		N/A
63023	617	376	NPSMP010	NPSMP022	NPDS003	#N/A	#N/A			N/A
63024	585	365	NPSMP011	NPSMP047	NPDS004	#N/A	#N/A			N/A
63024L	624	385	NPSMP011	NPSMP047	NPDS004	#N/A	#N/A			N/A
63025	584	365	NPSMP011	NPSMP011	NPDS004	#N/A	#N/A			N/A
63025L	624	385	NPSMP012	NPSMP012	NPDS004	#N/A	#N/A			N/A
63026	584	365	NPSMP011	NPSMP011	NPDS004	#N/A	#N/A			N/A
63027	532	328	NPSMP004	NPSMP005	NPDS003	#N/A	#N/A	3		N/A
63028	532	328	NPSMP004	NPSMP005	NPDS003	#N/A	#N/A	3		N/A
63029	615	371	NPSMP001	NPSMP045	NPDS003	#N/A	#N/A	2		N/A
63030	615	371	NPSMP001	NPSMP045	NPDS003	#N/A	#N/A	2		N/A
63031	374	247	NPSMP004	NPSMP032	NPDS008	#N/A	#N/A	3		N/A
63032	591	362	NPSMP013	NPSMP013	NPDS009	#N/A	#N/A			N/A
63033	368	258	NPSMP007	NPSMP007	NPDS006	#N/A	#N/A			N/A
63034	297	209	NPSMP004	NPSMP032	NPDS010	#N/A	#N/A	3		N/A
63035	556	348	NPSMP013	NPSMP013	NPDS011	#N/A	#N/A			NPSMP018
63036	557	349	NPSMP013	NPSMP013	NPDS012	#N/A	#N/A			NPSMP018
63037	553	329	NPSMP014	NPSMP014	NPDS003	#N/A	#N/A	2	2	N/A
63037L	593	349	NPSMP014	NPSMP014	NPDS003	#N/A	#N/A	2	2	N/A
63038	558	344	NPSMP015	NPSMP014	NPDS003	#N/A	#N/A		2	N/A
63039	558	344	NPSMP015	NPSMP014	NPDS003	#N/A	#N/A		2	N/A
63039L	598	364	NPSMP015	NPSMP014	NPDS003	#N/A	#N/A		2	N/A
63040	337	230	NPSMP004	NPSMP032	NPDS008	#N/A	#N/A	3		N/A
63041	467	297	NPSMP004	NPSMP048	NPDS013	#N/A	#N/A	3		N/A
63042	337	228	NPSMP004	NPSMP048	NPDS006	#N/A	#N/A	3		N/A
63043	648	399	NPSMP005	NPSMP005	NPDS004	#N/A	#N/A			N/A
63044	628	389	NPSMP005	NPSMP005	NPDS004	#N/A	#N/A			N/A

cont.

SPECIFICATIONS - SHOCK ABSORBERS

NITROCHARGER PLUS

Part Number	Open Length (mm)	Closed Length (mm)	Upper Mount Kit	Lower Mount Kit	Dirt Shield	Spring Seat	Spring Seat Spacer Kit / Snap Ring	SMP Type		Other SMP Kit
								Top/Bottom		
63046	562	337	NPSMP016	NPSMP049	NPDS013	#N/A	#N/A	6		N/A
63047	562	337	NPSMP016	NPSMP049	NPDS013	#N/A	#N/A	6		N/A
63047L	672	397	NPSMP016	NPSMP049	NPDS014	#N/A	#N/A	6		N/A
63048	556	343	NPSMP017	NPSMP050	NPDS003	#N/A	#N/A			N/A
63049	556	343	NPSMP017	NPSMP050	NPDS003	#N/A	#N/A			N/A
63049L	616	373	NPSMP017	NPSMP050	NPDS004	#N/A	#N/A			N/A
63050	651	397	NPSMP018	NPSMP018	NPDS007	#N/A	#N/A	10	10	N/A
63051	333	230	NPSMP004	NPSMP051	NPDS008	#N/A	#N/A	3		N/A
63052	562	347	NPSMP016	NPSMP049	NPDS004	#N/A	#N/A	6		N/A
63052L	672	397	NPSMP016	NPSMP049	NPDS014	#N/A	#N/A	6		N/A
63053	556	341	NPSMP017	NPSMP025	NPDS004	#N/A	#N/A			N/A
63053L	614	371	NPSMP017	NPSMP025	NPDS004	#N/A	#N/A			N/A
63054	632	378	NPSMP005	NPSMP004	NPDS004	#N/A	#N/A		3	N/A
63055	495	300	NPSMP006	NPSMP006	NPDS015	#N/A	#N/A	4	4	N/A
63056	500	317	NPSMP008	NPSMP048	NPDS015	#N/A	#N/A			N/A
63057	548	345	NPSMP013	NPSMP013	NPDS011	#N/A	#N/A			N/A
63058	596	372	NPSMP008	NPSMP008	NPDS007	#N/A	#N/A			N/A
63059	520	325	NPSMP013	NPSMP048	NPDS015	#N/A	#N/A			N/A
63061	479	294	NPSMP004	NPSMP032	NPDS015	#N/A	#N/A	3		N/A
63062	578	359	NPSMP005	NPSMP005	NPDS004	#N/A	#N/A			N/A
63063	577	348	NPSMP004	NPSMP005	NPDS004	#N/A	#N/A	3		N/A
63064	591	362	NPSMP013	NPSMP013	NPDS009	#N/A	#N/A			N/A
63065	578	359	NPSMP005	NPSMP005	NPDS004	#N/A	#N/A			N/A
63066	582	358	NPSMP019	NPSMP022	NPDS002	#N/A	#N/A	1		N/A
63066M	652	388	NPSMP019	NPSMP022	NPDS016	#N/A	#N/A	1		N/A
63066L	702	418	NPSMP019	NPSMP022	NPDS016	#N/A	#N/A	1		N/A
63067	612	371	NPSMP017	NPSMP022	NPDS003	#N/A	#N/A			N/A
63067L	706	421	NPSMP017	NPSMP022	NPDS002	#N/A	#N/A			N/A
63068	497	308	NPSMP004	NPSMP005	NPDS015	#N/A	#N/A	3		N/A
63069	567	358	NPSMP020	NPSMP052	NPDS007	#N/A	#N/A			N/A
63070	616	356	NPSMP002	NPSMP002	NPDS003	#N/A	#N/A	1	1	N/A
63070L	665	390	NPSMP002	NPSMP002	NPDS002	#N/A	#N/A	1	1	N/A
63071	624	377	NPSMP002	NPSMP005	NPDS003	#N/A	#N/A	1		N/A
63071L	671	397	NPSMP002	NPSMP005	NPDS002	#N/A	#N/A	1		N/A
63072	377	248	NPSMP004	NPSMP048	NPDS006	#N/A	#N/A	3		N/A
63073	542	329	NPSMP004	NPSMP005	NPDS013	#N/A	#N/A	3		N/A
63074	514	329	NPSMP021	NPSMP005	NPDS015	#N/A	#N/A			N/A
63075	517	325	NPSMP008	NPSMP048	NPDS015	#N/A	#N/A			N/A
63076	517	325	NPSMP008	NPSMP048	NPDS015	#N/A	#N/A			N/A
63077	580	351	NPSMP004	NPSMP053	NPDS003	#N/A	#N/A	3		N/A
63078	580	351	NPSMP004	NPSMP053	NPDS003	#N/A	#N/A	3		N/A
63080	601	367	NPSMP002	NPSMP045	NPDS003	#N/A	#N/A	1		N/A
63081	601	367	NPSMP002	NPSMP045	NPDS003	#N/A	#N/A	1		N/A
63082	594	370	NPSMP022	NPSMP022	NPDS007	#N/A	#N/A			N/A
63083	594	370	NPSMP022	NPSMP022	NPDS007	#N/A	#N/A			N/A
63086	581	357	NPSMP002	NPSMP045	NPDS017	#N/A	#N/A	1		N/A
63087	539	334	NPSMP016	NPSMP049	NPDS013	#N/A	#N/A	6		N/A
63088	574	354	NPSMP020	NPSMP024	NPDS013	#N/A	#N/A			N/A
63089	562	342	NPSMP023	NPSMP004	NPDS013	#N/A	#N/A		3	N/A
63090	502	313	NPSMP005	NPSMP004	NPDS015	#N/A	#N/A		3	N/A
63091	599	354	NPSMP004	NPSMP054	NPDS003	#N/A	#N/A	3		N/A
63092	562	347	NPSMP016	NPSMP049	NPDS004	#N/A	#N/A	6		N/A
63093	559	345	NPSMP024	NPSMP025	NPDS013	#N/A	#N/A			N/A

cont.

SPECIFICATIONS - SHOCK ABSORBERS

NITROCHARGER PLUS

Part Number	Open Length (mm)	Closed Length (mm)	Upper Mount Kit	Lower Mount Kit	Dirt Shield	Spring Seat	Spring Seat Spacer Kit / Snap Ring	SMP Type Top/Bottom		Other SMP Kit
63094	477	292	NPSMP006	NPSMP006	NPDS015	#N/A	#N/A	4	4	N/A
63095	442	278	NPSMP004	NPSMP005	NPDS015	#N/A	#N/A	3		N/A
63096	534	339	NPSMP005	NPSMP005	NPDS013	#N/A	#N/A			N/A
63097	496	312	NPSMP025	NPSMP025	NPDS015	#N/A	#N/A			N/A
63098	617	367	NPSMP016	NPSMP050	NPDS004	#N/A	#N/A	6		N/A
63099	501	332	NPSMP026	NPSMP050	NPDS013	#N/A	#N/A			N/A
63100	656	392	NPSMP001	NPSMP022	NPDS017	#N/A	#N/A	2		N/A
63101	618	376	NPSMP010	NPSMP022	NPDS002	#N/A	#N/A			N/A
63102	618	376	NPSMP010	NPSMP022	NPDS002	#N/A	#N/A			N/A
63109	648	399	NPSMP005	NPSMP005	NPDS004	#N/A	#N/A			N/A
63110	556	347	NPSMP008	NPSMP046	NPDS004	#N/A	#N/A			N/A
63111	658	399	NPSMP005	NPSMP005	NPDS003	#N/A	#N/A			N/A
63112	579	355	NPSMP002	NPSMP045	NPDS003	#N/A	#N/A	1		N/A
63113	600	370	NPSMP027	NPSMP001	NPDS004	#N/A	#N/A		2	N/A
63114	609	370	NPSMP001	NPSMP056	NPDS004	#N/A	#N/A	2		N/A
63116	551	342	NPSMP013	NPSMP013	NPDS003	#N/A	#N/A			N/A
63117	551	342	NPSMP013	NPSMP013	NPDS003	#N/A	#N/A			N/A
63121	618	372	NPSMP001	NPSMP030	NPDS004	#N/A	#N/A	2		N/A
63122	783	455	NPSMP026	NPSMP036	NPDS014	#N/A	#N/A			N/A
63123	558	342	NPSMP001	NPSMP030	NPDS013	#N/A	#N/A	2		N/A
63124	584	413	NPSMP028	#N/A	#N/A	#N/A	#N/A	8		N/A
63125	584	413	NPSMP028	#N/A	#N/A	#N/A	#N/A	8		N/A
63126	540	382	NPSMP029	#N/A	#N/A	#N/A	#N/A	2		N/A
63127	540	382	NPSMP029	#N/A	#N/A	#N/A	#N/A	2		N/A
63130	588	359	NPSMP004	NPSMP044	NPDS004	#N/A	#N/A	3		N/A
63131	588	359	NPSMP004	NPSMP044	NPDS004	#N/A	#N/A	3		N/A
63132	628	389	NPSMP003 (1 kit req)		NPDS003	#N/A	#N/A			N/A
63133	628	389	NPSMP003 (1 kit req)		NPDS003	#N/A	#N/A			N/A
63134	615	372	NPSMP013	NPSMP013	NPDS003	#N/A	#N/A			N/A
63135	646	392	NPSMP013	NPSMP013	NPDS003	#N/A	#N/A			N/A
63136	608	378	NPSMP013	NPSMP046	NPDS003	#N/A	#N/A			N/A
63137	608	378	NPSMP013	NPSMP046	NPDS003	#N/A	#N/A			N/A
63138	531	342	NPSMP008	NPSMP008	NPDS012	#N/A	#N/A			N/A
63139	531	342	NPSMP008	NPSMP008	NPDS012	#N/A	#N/A			N/A
63140	531	342	NPSMP008	NPSMP008	NPDS012	#N/A	#N/A			N/A
63141	580	351	NPSMP004	NPSMP045	NPDS003	#N/A	#N/A	3		N/A
63142	580	351	NPSMP004	NPSMP045	NPDS003	#N/A	#N/A	3		N/A
63144	590	352	NPSMP028	NPSMP057	#N/A	#N/A	#N/A	8		N/A
63145	590	352	NPSMP028	NPSMP057	#N/A	#N/A	#N/A	8		N/A
63146	535	321	NPSMP014	NPSMP014	NPDS003	#N/A	#N/A	2	2	N/A
63147	535	321	NPSMP014	NPSMP014	NPDS003	#N/A	#N/A	2	2	N/A
63148	588	373	NPSMP030	NPSMP030	NPDS004	#N/A	#N/A			N/A
63149	588	373	NPSMP030	NPSMP030	NPDS004	#N/A	#N/A			N/A
63150	690	444	NPSMP031	NPSMP012	NPDS016	#N/A	#N/A			N/A
63151	725	459	NPSMP031	NPSMP012	NPDS016	#N/A	#N/A			N/A
63152	498	366	NPSMP028	#N/A	#N/A	#N/A	#N/A	8		N/A
63153	498	366	NPSMP028	#N/A	#N/A	#N/A	#N/A	8		N/A
63154	450	285	NPSMP004	NPSMP032	NPDS012	#N/A	#N/A	3		N/A
63155	506	323	NPSMP032	NPSMP032	NPDS012	#N/A	#N/A			N/A
63156	621	386	NPSMP033	NPSMP033	NPDS004	#N/A	#N/A			N/A
63157	621	386	NPSMP033	NPSMP033	NPDS004	#N/A	#N/A			N/A
63160	628	399	NPSMP031	NPSMP012	NPDS002	#N/A	#N/A			N/A
63161	693	444	NPSMP031	NPSMP012	NPDS016	#N/A	#N/A			N/A

cont.

SPECIFICATIONS - SHOCK ABSORBERS

NITROCHARGER PLUS

Part Number	Open Length (mm)	Closed Length (mm)	Upper Mount Kit	Lower Mount Kit	Dirt Shield	Spring Seat	Spring Seat Spacer Kit / Snap Ring	SMP Type		Other SMP Kit
								Top/Bottom		
63162	628	399	NPSMP031	NPSMP012	NPDS002	#N/A	#N/A			N/A
63163	693	444	NPSMP031	NPSMP012	NPDS016	#N/A	#N/A			N/A
63164	698	423	NPSMP034	NPSMP034	NPDS014	#N/A	#N/A			N/A
63165	698	423	NPSMP034	NPSMP034	NPDS014	#N/A	#N/A			N/A
63167	611	372	NPSMP013	NPSMP013	NPDS003	#N/A	#N/A			NPSMP018
63168	611	372	NPSMP013	NPSMP013	NPDS003	#N/A	#N/A			NPSMP018
63172	660	422	NPSMP022	NPSMP022	NPDS017	#N/A	#N/A			N/A
63173	660	422	NPSMP022	NPSMP022	NPDS017	#N/A	#N/A			N/A
63174	590	352	NPSMP028	NPSMP057	#N/A	#N/A	#N/A	8		N/A
63175	590	352	NPSMP028	NPSMP057	#N/A	#N/A	#N/A	8		N/A
63176	670	395	NPSMP001	NPSMP045	NPDS017	#N/A	#N/A	2		N/A
63177	670	395	NPSMP001	NPSMP045	NPDS017	#N/A	#N/A	2		N/A
63178	660	422	NPSMP022	NPSMP022	NPDS017	#N/A	#N/A			N/A
63381	675	404	NPSMP001	NPSMP045	NPDS014	#N/A	#N/A	2		N/A
63382	675	404	NPSMP001	NPSMP045	NPDS014	#N/A	#N/A	2		N/A
63383	497	314	NPSMP004	NPSMP036	NPDS011	#N/A	#N/A	3		N/A
63385	590	373	NPSMP035	NPSMP035	NPDS008	#N/A	#N/A			N/A
63386	497	314	NPSMP004	NPSMP058	NPDS011	#N/A	#N/A	3		N/A
63387	478	302	NPSMP004	NPSMP025	NPDS011	#N/A	#N/A	3		N/A
63388	492	318	NPSMP025	NPSMP025	NPDS011	#N/A	#N/A			N/A
63389	389	256	NPSMP004	NPSMP025	NPDS008	#N/A	#N/A	3		N/A
63390	462	302	NPSMP025	NPSMP025	NPDS011	#N/A	#N/A			NPSMP018
63391	389	256	NPSMP004	NPSMP025	NPDS008	#N/A	#N/A	3		N/A
63392	558	351	NPSMP036	NPSMP036	NPDS011	#N/A	#N/A			N/A
63393	463	293	NPSMP005	NPSMP014	NPDS015	#N/A	#N/A		2	N/A
63394	447	292	NPSMP005	NPSMP005	NPDS015	#N/A	#N/A			N/A
63402	660	422	NPSMP022	NPSMP022	NPDS017	#N/A	#N/A			N/A
63403	660	422	NPSMP022	NPSMP022	NPDS017	#N/A	#N/A			N/A
93000	563	426	NPSMP037	NPSMP059	NPDS018	NPSS01	NPSR01			N/A
93002	563	436	NPSMP038	NPSMP059	NPDS018	NPSS01	NPSR01			N/A
93003	387	283	NPSMP028	NPSMP060	NPDS019	NPSS01	NPSR01	8		N/A
93004	467	339	NPSMP006	NPSMP059	NPDS018	NPSS01	NPSR01	4		N/A
93005	605	429	NPSMP039	NPSMP061	NPDS020	NPSS01	NPSR01			N/A
93006	471	327	NPSMP040	NPSMP062	#N/A	NPSS02	NPSR02	8		N/A
93007	471	327	NPSMP040	NPSMP062	#N/A	NPSS02	NPSR02	8		N/A
93008	423	303	NPSMP040	NPSMP062	#N/A	NPSS02	NPSR02	8		N/A
93009	321	205	NPSMP040	#N/A	NPDS021	NPSS02	NPSR02	8		N/A
93010	563	428	NPSMP028	NPSMP063	NPDS019	NPSS01	NPSR01	8		N/A
93011	563	436	NPSMP038	NPSMP059	NPDS018	NPSS01	NPSR01			N/A
93012	612	482	NPSMP028	#N/A	#N/A	NPSS02	NPSR02	8		N/A
93013	612	482	NPSMP028	#N/A	#N/A	NPSS02	NPSR02	8		N/A
93017	605	429	NPSMP039	NPSMP061	NPDS020	NPSS01	NPSR01			N/A
93018	609	456	NPSMP028	NPSMP064	NPDS019	NPSS01	NPSR01	8		N/A
93019	497	367	NPSMP037	NPSMP065	NPDS018	NPSS01	NPSR01			N/A
93020	497	367	NPSMP037	NPSMP065	NPDS018	NPSS01	NPSR01			N/A
93022	491	351	NPSMP028	NPSMP059	NPDS018	NPSS01	NPSR01	8		N/A
93023	491	351	NPSMP028	NPSMP059	NPDS018	NPSS01	NPSR01	8		N/A
93026	814	666	NPSMP028	#N/A	#N/A	NPSS01	NPSR01	8		N/A
93028	558	428	NPSMP041	NPSMP063	NPDS018	NPSS01	NPSR01			N/A
93029	558	428	NPSMP041	NPSMP063	NPDS018	NPSS01	NPSR01			N/A
93031	423	303	NPSMP040	NPSMP062	#N/A	NPSS02	NPSR02	8		N/A
93032	392	294	NPSMP028	NPSMP063	NPDS018	NPSS01	NPSR01	8		N/A
93033	423	303	NPSMP040	NPSMP062	#N/A	NPSS02	NPSR02	8		N/A

cont.

SPECIFICATIONS - SHOCK ABSORBERS

NITROCHARGER PLUS

Part Number	Open Length (mm)	Closed Length (mm)	Upper Mount Kit	Lower Mount Kit	Dirt Shield	Spring Seat	Spring Seat Spacer Kit / Snap Ring	SMP Type Top/Bottom		Other SMP Kit
93035	814	666	NPSMP028	#N/A	#N/A	NPSS01	NPSR01	8		N/A
93036	814	666	NPSMP028	#N/A	#N/A	NPSS01	NPSR01	8		N/A
93037	494	366	NPSMP040	NPSMP059	NPDS022	NPSS01	NPSR01	8		N/A
93038	493	378	NPSMP028	NPSMP066	#N/A	NPSS01	NPSR01	8		N/A
93039	493	378	NPSMP028	NPSMP066	#N/A	NPSS01	NPSR01	8		N/A
93040	510	353	NPSMP042	NPSMP067	#N/A	NPSS01	NPSR01	-		N/A
93044	539	392	NPSMP028	#N/A	#N/A	NPSS01	NPSR01	8		N/A
93045	501	351	NPSMP037	NPSMP059	NPDS018	NPSS01	NPSR01			N/A
93046	501	351	NPSMP037	NPSMP059	NPDS018	NPSS01	NPSR01			N/A
93047	574	405	NPSMP028	NPSMP067	#N/A	NPSS01	NPSR01	8		N/A
93048	688	427	NPSMP028	NPSMP068	#N/A	NPSS01	NPSR01	8		N/A
93051	583	386	NPSMP028	NPSMP066	#N/A	NPSS01	NPSR01	8		N/A
93052	560	391	NPSMP028	NPSMP069	#N/A	NPSS01	NPSR01	8	7	N/A
93053	560	391	NPSMP028	NPSMP069	#N/A	NPSS01	NPSR01	8	7	N/A
93054	625	447	NPSMP043	NPSMP070	NPDS022	NPSS01	NPSR01	8		N/A
93055	625	447	NPSMP043	NPSMP070	NPDS022	NPSS01	NPSR01	8		N/A
93194	473	339	NPSMP040	NPSMP071	#N/A	NPSS01	NPSR01	8		N/A
93195	501	318	NPSMP043	#N/A	#N/A	NPSS01	NPSR01	8		N/A
93196	593	393	NPSMP028	#N/A	#N/A	#N/A	#N/A	8		N/A
93197	593	393	NPSMP028	#N/A	#N/A	#N/A	#N/A	8		N/A
93400	560	391	NPSMP028	NPSMP069	#N/A	NPSS01	NPSR01	8	7	N/A
93401	560	391	NPSMP028	NPSMP069	#N/A	NPSS01	NPSR01	8	7	N/A

SPECIFICATIONS - SHOCK ABSORBERS

NITROCHARGER SPORT

Part Number	Open Length (mm)	Closed Length (mm)	Type	UPPER MOUNT BUSH KIT		Type	LOWER MOUNT BUSH KIT	
				Original Kit	Bushes only Replacement		Original Kit	Bushes only Replacement
60000	443	298	P4203	SMP493	N/A	E4050-BS	110-110-122	110-110-122
60001	443	298	P4203	SMP493	SMP493	E4050-BS	110-110-122	110-110-122
60002	612	368	P4204	SMP493	SMP493	E4005	110-034-069 ¹	OMEB40
60003	612	368	P4204	SMP493	SMP493	E4005	110-034-069 ¹	OMEB40
60004	580	356	P4184	SMP569	N/A	E4005	SMP621	OMEB40
60005	580	356	P4184	SMP569	SMP569	E4005	SMP621	OMEB40
60006	600	373	E4005	SMP649	SMP649	E4005	SMP649	SMP649
60007	597	373	E4005	SMP649	SMP649	E4005	SMP649	SMP649
60008	524	319	P4184	SMP501	OMEB42	P4184	SMP501	OMEB42
60009	589	349	P4169	SMP474	OMEB13	E4005	110-034-070	OMEB36
60010	652	403	E4005	110-034-070	OMEB15	E4005	110-034-070	OMEB15
60011	657	403	E4005	110-034-070	OMEB15	E4005	110-034-070	OMEB15
60012 ¹	496	301	P4184	SMP345	OMEB42	P4184	SMP345	OMEB42
60013	496	301	P4184	SMP345	OMEB42	P4184	SMP345	OMEB42
60013L	555	322	P4184	SMP345	OMEB42	P4184	SMP345	OMEB42
60014 ¹	657	403	E4005	SMP363	OMEB36	E4005	SMP363	OMEB40
60015	657	403	E4005	SMP363	OMEB36	E4005	SMP363	OMEB40
60015L	716	426	E4005	SMP363	OMEB36	E4005	SMP363	OMEB40
60016	376	262	E4051-S	110-110-076	N/A	E4051-S	110-110-076	N/A
60017	559	350	E4001	110-043-071	OMEB14	E4063-S	110-110-100	N/A
60018	617	359	P4184	SMP501	OMEB42	P4184	SMP501	OMEB42
60018L	667	381	P4184	SMP501	OMEB42	P4184	SMP501	OMEB42
60019	582	354	P4158	SMP641	N/A	E4040-BS	110-110-076	N/A
60020	625	378	P4184	SMP501	OMEB42	E4005	110-034-070	OMEB36
60020L	673	378	P4184	SMP501	OMEB42	E4005	110-034-070	OMEB36
60021	325	215	P4169	SMP474	OMEB13	E4026-S	110-A42-074	OMEB10
60022	363	239	P4205	SMP670	OMEB13	E4050	110-A42-126	110-A42-126
60023	624	380	E4005	110-110-113	N/A	E4005BS	110-034-080	-
60024	587	368	E4005-S	110-110-066	N/A	E4005-T	110-110-067	N/A
60024L	627	388	E4005-S	110-110-066	N/A	E4005-T	110-110-067	N/A
60025	587	368	E4005-S	110-110-066	N/A	E4005-BS	110-110-066	110-110-066
60025L	627	388	E4005-S	110-110-066	N/A	E4005-BS	110-110-066	N/A
60026	593	368	E4005-S	110-110-066	N/A	E4005-BS	110-110-066	110-110-066
60027	545	338	P4169	SMP474	OMEB13	E4005	110-034-070	OMEB15
60028	545	338	P4169	SMP474	OMEB13	E4005	110-034-070	OMEB15
60029 ¹	615	368	P4204	SMP493	N/A	E4005	110-034-069 ¹	OMEB40
60030 ¹	615	368	P4204	SMP493	N/A	E4005	110-034-069 ¹	OMEB40
60031	385	250	P	SMP675	OMEB13	E4026-S	110-A42-074	OMEB10
60032	597	365	E4001	*110-034-071	OMEB14	E4001	110-034-071	OMEB14
60033	581	354	P4158	SMP641	N/A	E4051-BS	110-110-076	N/A
60034	311	208	P4205	SMP474	OMEB13	E4026-S	110-A42-074	OMEB10
60035	560	345	E4001	SMP516	OMEB14	E4001	SMP511	OMEB14
60036	559	339	E4001	SMP516	OMEB14	E4001	SMP511	OMEB14
60037	553	329	P4184	SMP374	OMEB42	P4184	SMP374	OMEB42
60037L	593	349	P4184	SMP374	OMEB42	P4184	SMP374	OMEB42
60038	560	346	E4005	110-034-069 ¹	OMEB40	P4184	SMP683	SMP683
60039	560	346	E4005	110-034-069 ¹	OMEB40	P4184	SMP683	SMP683
60039L	600	366	E4005	110-034-069 ¹	OMEB40	P4184	SMP683	N/A
60040	345	225	P4169	SMP474	OMEB13	E4026-S	110-A42-074	OMEB10
60041	478	304	P4169	SMP474	OMEB13	E4001	110-034-077 ¹	OMEB17
60042	352	232	P4169	SMP474	OMEB13	E4005-S	110-034-072	OMEB17
60043	660	397	E4005	110-034-070	OMEB15	E4005	110-034-070	OMEB15
60044	640	390	E4005	110-034-070	OMEB15	E4005	110-034-070	OMEB15

Note: Bush kits with part numbers starting with SMP indicate the kits have the urethane bush, mounting nut & washers.

*Also supplied with SMP495 spacer kit

1. When remaining stock is exhausted no further product will be available.

See Shock Absorber Mout Types section for legend of mount types.

cont.

SPECIFICATIONS - SHOCK ABSORBERS

NITROCHARGER SPORT

Part Number	Open Length (mm)	Closed Length (mm)	Type	UPPER MOUNT BUSH KIT		Type	LOWER MOUNT BUSH KIT	
				Original Kit	Bushes only Replacement		Original Kit	Bushes only Replacement
60045	642	382	E - TB	N/A	N/A	E - S	N/A	N/A
60046	565	334	P4169	SMP476	N/A	E4026-TB	110-110-088	N/A
60047	565	334	P4169	SMP476	N/A	E4026-TB	110-110-088	N/A
60047L	678	392	P4169	SMP476	N/A	E4026-TB	110-110-088	N/A
60048	559	338	E4026-TB	110-110-089	N/A	E4026-S	110-A42-102	N/A
60049	559	338	E4026-TB	110-110-089	N/A	E4026-S	110-A42-102	N/A
60049L	622	366	E4026-TB	110-110-089	N/A	E4026-S	110-A42-102	N/A
60050	659	389	E4001	110-110-071	OMEB14	E4001	110-110-071	OMEB14
60051	339	224	P4169	SMP670	OMEB13	E4026-T	110-110-078	110034078
60052	565	344	P4169	SMP476	N/A	E4026-T	110-110-088	110-110-088
60052L	678	392	P4169	SMP476	N/A	E4026-TB	110-110-088	N/A
60053	559	338	E4026-T	110-110-089	110-110-089	E4026-S	110-A42-102	OMEB10
60053L	622	366	E4026-TB	110-110-089	N/A	E4026-S	110-A42-102	OMEB10
60054	644	384	E4005	SMP517 ¹	OMEB36	P4169	SMP474	OMEB13
60055	496	301	P4184	SMP345	OMEB42	P4184	SMP345	OMEB42
60056	503	312	E4001	110-110-071	OMEB14	E4005-S	N/A	OMEB17
60057	559	339	E4001	SMP516	OMEB14	E4001	SMP516	OMEB14
60058	619	369	E4001	110-110-071	OMEB14	E4001	110-110-071	OMEB14
60059	523	329	E4001	110-034-071	OMEB14	E4005-S	110-034-072	OMEB17
60060	528	318	P4205	SMP474	OMEB13	E4050	SMP650 ¹	OMEB15
60061	485	294	P4169	SMP474	OMEB13	E4026-S	110-A42-074	OMEB10
60062	587	357	E4005	110-034-070	OMEB15	E4005	110-034-070	OMEB15
60063	588	348	P4169	SMP474	OMEB13	E4005	110-034-070	OMEB36
60064	594	360	E4005	110-034-071	OMEB14	E4005	110-034-071	OMEB14
60065	581	356	E4005	110-034-070	OMEB15	E4005	110-034-070	OMEB15
60066	580	348	P4184	SMP658	OMEB42	E	N/A	N/A
60066L	693	404	P4184	SMP658	OMEB42	E	N/A	N/A
60066M	646	382	P4184	SMP658	OMEB42	E	N/A	N/A
60067	619	368	E-TB	110-A42-126	N/A	E	110-A42-126	N/A
60067L	706	422	E-TB	110-110-105	N/A	E	110-110-105	N/A
60068	509	314	P4169	SMP474	OMEB13	E4005	110-034-070	OMEB15
60069	576	362	E4057-S	110-110-085	N/A	E4005-S	110-110-086 ¹	N/A
60070	617	359	P4184	SMP501	OMEB42	P4184	SMP501	OMEB42
60070L	667	381	P4184	SMP501	OMEB42	P4184	SMP501	OMEB42
60071	625	378	P4184	SMP501	OMEB42	E4005	110-034-070	OMEB36
60071L	673	387	P4184	SMP501	OMEB42	E4005	110-034-070	OMEB36
60072	383	254	P4169	SMP474	OMEB13	E4005-S	110-034-072	OMEB17
60073	549	334	P4169	SMP474	OMEB13	E4005	110-034-070	OMEB36
60074	517	333	E4005-S	110-034-072	OMEB17	E4005	110-034-070	OMEB15
60075	523	329	E4001	110-034-071	OMEB14	E4005-S	110-034-072	OMEB17
60076	523	329	E4001	110-034-071	OMEB14	E4005-S	110-034-072	OMEB17
60077	583	354	P4205	SMP474	OMEB13	E4005-S	110-034-070	OMEB15
60078	583	354	P4205	SMP474	OMEB13	E4005-S	110-034-070	OMEB15
60080	603	368	P4184	SMP569	SMP569	E4005	SMP621	OMEB40
60081	603	368	P4184	SMP569	SMP569	E4005	SMP621	OMEB40
60082	602	368	N/A	N/A	N/A	N/A	N/A	N/A
60083	602	368	N/A	N/A	N/A	N/A	N/A	N/A
60084	560	350	P	SMP705	N/A	E	110-110-126	N/A
60085 ¹	560	350	P	SMP705	N/A	E	110-110-126	N/A
60086	603	368	P4184	SMP569	SMP569	E4005	SMP621	OMEB40
60087	535	330	P4170	SMP312	N/A	E4026-T	SMP487	N/A
60088	580	355	E4057-S	110-110-085	N/A	E4001	110-034-020 ¹	OMEB10
60089	569	338	E-4032-S	110-034-070	N/A	P4169	SMP474	OMEB13
60090	508	308	E4005	110-034-070	OMEB15	P4169	SMP474	OMEB13

Note: Bush kits with part numbers starting with SMP indicate the kits have the urethane bush, mounting nut & washers.

1. When remaining stock is exhausted no further product will be available.

See Shock Absorber Mout Types section for legend of mount types.

cont.

SPECIFICATIONS - SHOCK ABSORBERS

NITROCHARGER SPORT

Part Number	Open Length (mm)	Closed Length (mm)	Type	UPPER MOUNT BUSH KIT		Type	LOWER MOUNT BUSH KIT	
				Original Kit	Bushes only Replacement		Original Kit	Bushes only Replacement
60091	599	360	P4205	SMP474	OMEB13	E4026-S	110-A42-074	N/A
60092	565	345	P14969	SMP476	OMEB13	E4026-T	110-110-038	N/A
60093	562	343	E4003	110-034-076	N/A	E4026-S	110-034-056	OMEB10
60094	469	291	P4184	SMP345	OMEB42	P4184	SMP345	OMEB42
60095	442	284	P4169	SMP474	OMEB13	E4005	110-034-070	OMEB15
60096	531	342	E4005	110-064-070	OMEB15	E4005	110-064-070	OMEB15
60097	493	315	E4001	110-034-071	OMEB14	E4001	110-034-071	OMEB14
60098	625	365	P4169	SMP476	OMEB13	E4026-S	110-A42-102	OMEB10
60099	509	329	E4001	110-034-065 ¹	OMEB14	E4026-S	110-A42-102	OMEB10
60100	650	385	P	SMP493	N/A	E	110-110-102 ¹	N/A
60101	624	380	E4005	110-110-113	N/A	E4005-BS	110-A42-126	N/A
60102	624	380	E4005	110-110-113	N/A	E4005-BS	110-A42-126	N/A
60109	685	420	E4005	110-034-070	OMEB15	E4005	110-034-070	OMEB15
60110	559	350	E4001	110-034-071	OMEB14	E4063S	110-110-100	N/A
60111	665	400	E4005	110-034-070	OMEB15	E4005	110-034-070	OMEB15
60112	580	356	P4184	SMP569	N/A	E4005	SMP621	OMEB40
60113	600	365	E	110-A42-139	N/A	P	SMP706	N/A
60114	610	365	P	SMP706	N/A	E	110-110-077	N/A
60116	555	340	E4005	110-034-071	OMEB14	E4005	110-034-071	OMEB14
60117	555	340	E4005	110-034-071	OMEB14	E4005	110-034-071	OMEB14
60121	620	370	P	SMP493	N/A	E	110-110-103	N/A
60122	785	460	E	SMP657	N/A	E	110-A42-124 ¹	N/A
60123	560	340	P4204	SMP493	-	E4051-S	110-110-103	110-110-103
60124	585	415	P	SMP712	N/A	CLEVIS	N/A	N/A
60125	585	415	P	SMP712	N/A	CLEVIS	N/A	N/A
60126	550	385	P	SMP725	N/A	CLEVIS	N/A	N/A
60127	550	385	P	SMP725	N/A	CLEVIS	N/A	N/A
60130	595	363	P	SMP474	N/A	E	110-110-103	N/A
60131	595	363	P	SMP474	N/A	E	110-110-103	N/A
60132	627	390	E	SMP649	N/A	E	SMP649	N/A
60133	627	390	E	SMP649	N/A	E	SMP649	N/A
60134	617	372	E	110-034-071	N/A	E	110-034-071	N/A
60135	647	392	E	110-034-071	N/A	E	110-034-071	N/A
60136	608	379	E	110-034-071	N/A	E	110-110-115	N/A
60137	608	379	E	110-034-071	N/A	E	110-110-115	N/A
60138	530	330	E	110-034-071	N/A	E	110-034-071	N/A
60139	530	330	E	110-034-071	N/A	E	110-034-071	N/A
60140	530	330	E	110-034-071	N/A	E	110-034-071	N/A
60141	583	354	P	SMP474	OMEB13	E	SMP621	OMEB40
60142	583	354	P	SMP474	OMEB13	E	SMP621	OMEB40
60144	586	352	P	Use OE	Use OE	E	110-110-128	N/A
60145	586	352	P	Use OE	Use OE	E	110-110-128	N/A
60146	530	320	P	SMP683	N/A	P	SMP683	N/A
60147	530	320	P	SMP683	N/A	P	SMP683	N/A
60148	595	375	E	110-110-092	N/A	E	110-110-092	N/A
60149	595	375	E	110-110-092	N/A	E	110-110-092	N/A
60150	685/640	445	E	110-110-134	N/A	E	110-110-133	N/A
60151	720/675	460	E	110-110-134	N/A	E	110-110-133	N/A
60152	500	365	P	SMP633	N/A	Clevis	N/A	N/A
60153	500	365	P	SMP633	N/A	Clevis	N/A	N/A
60154	440	280	P	SMP474	N/A	E	110110009	N/A
60155	515	325	E	110110009	N/A	E	110110009	N/A
60156	625	385	E	110-A42-126	N/A	E	110-A42-126	N/A
60157	625	385	E	110-A42-126	N/A	E	110-A42-126	N/A

Note: Bush kits with part numbers starting with SMP indicate the kits have the urethane bush, mounting nut & washers.

1. When remaining stock is exhausted no further product will be available.

cont.

See Shock Absorber Mout Types section for legend of mount types.

SPECIFICATIONS - SHOCK ABSORBERS

NITROCHARGER SPORT

Part Number	Open Length (mm)	Closed Length (mm)	Type	UPPER MOUNT BUSH KIT		Type	LOWER MOUNT BUSH KIT	
				Original Kit	Bushes only Replacement		Original Kit	Bushes only Replacement
60160	630	400	E	110-110-134	N/A	E	110-110-133	N/A
60161	695	445	E	110-110-134	N/A	E	110-110-133	N/A
60162	630	400	E	110-110-134	N/A	E	110-110-133	N/A
60163	695	445	E	110-110-134	N/A	E	110-110-133	N/A
60164	698	423	E	100-800-588	N/A	E	100-800-588	N/A
60165	698	423	E	100-800-588	N/A	E	100-800-588	N/A
60167	610	370	E	SMP495	110-034-071	E	N/A	110-034-071
60168	610	370	E	SMP495	110-034-071	E	N/A	110-034-071
60169	627	390		SMP649	N/A		SMP649	N/A
60171	627	390		SMP649	N/A		SMP649	N/A
60172	660	418	E	110-A42-149	N/A	E	110-A42-149	N/A
60173	660	418	E	110-A42-149	N/A	E	110-A42-149	N/A
60174	592	352	P	SMP660	N/A	E	SMP660	N/A
60175	592	352	P	SMP660	N/A	E	SMP660	N/A
60176	665	395	P	SMP718	N/A	E	110-034-069 ¹	N/A
60177	665	395	P	SMP718	N/A	E	110-034-069 ¹	N/A
60178	660	418	E	110-A42-149	N/A	E	110-A42-149	N/A
61012	496	301	P4184	SMP345	OMEB42	P4184	SMP345	OMEB42
61014	657	403	E4005	SMP363	OMEB36	E4005	SMP363	OMEB40
61029	615	368	P4204	SMP718	N/A	E4005	110-034-069 ¹	OMEB40
61030	615	368	P4204	SMP718	N/A	E4005	110-034-069 ¹	OMEB40
90000	543	413	P	OME3133	OME3133	E4050-S	110-110-122	110-110-122
90001	404	273	P	N/A	N/A	N/A	110-110-100	110-110-100
90002	548	413	P	OME3133	OME3133	E4050-S	110-110-122	110-110-122
90003	390	287	P	SMP633	N/A	E4063-BS	110-110-100	110-110-100
90003 (02/11 on)	390	287	P	SMP633	N/A	E4063-BS	110-110-112	110-110-112
90004	473	340	P	SMP673	N/A	E4050-B	110-110-122	110-110-122
90005 ¹	613	432	P4214	OE	OE	E4066	110-110-110	110-110-110
90006	474	330	N/A	Use OE Bushes	N/A	E4055BS	110-110-075	N/A
90006 (10/15 on)	474	330	N/A	Use OE Bushes	N/A	E4055BS	110-110-125	N/A
90007	474	330	P	Use OE Bushes	N/A	E4055BS	110-110-125	N/A
90008	426	306	P	N/A	N/A	E4055BS	110-110-125	N/A
90009	319	207	P	Use OE Bushes	N/A	N/A	N/A	N/A
90010	543	413	P	Use OE Bushes	N/A	E4050-S	110-110-112	110-110-112
90010 (09/13 on)	543	413	P	Use OE Bushes	N/A	E4050-S	110-110-115	110-110-115
90011	548	413	P	SMP626	SMP626	E4050-S	110-110-122	110-110-122
90012	615	485	P	SMP698	N/A	N/A	N/A	N/A
90013	615	485	P	SMP698	N/A	N/A	N/A	N/A
90014	458	297	P	SMP672	OE	E	110-110-117	N/A
90015	458	297	P	SMP672	OE	E	110-110-117	N/A
90016	543	413	P	Use OE Bushes	N/A	E4050-S	110-110-112	110-110-112
90016 (09/13 on)	543	413	P	Use OE Bushes	N/A	E4050-S	110-110-112	110-110-115
90017	613	432	P4124	OE	OE	E4066	110-110-110	N/A
90018	610	455	P	SMP710	N/A	E	110-110-101	N/A
90019	505	368	P	SMP709	OE	E	N/A	110-110-129
90020	505	368	P	SMP709	OE	E	N/A	110-110-129
90021	543	413	P	SMP671	SMP671	E4050-S	110-110-122	110-110-122
90022	495	350	P	Use OE Bushes	N/A	N/A	110-110-122	N/A
90023	495	350	P	Use OE Bushes	N/A	N/A	110-110-122	N/A
90026	815	665	P	SMP719	N/A	CLEVIS	N/A	N/A
90028	560	430	P	N/A	N/A	E	110-110-115	N/A
90029	560	430	P	N/A	N/A	E	110-110-115	N/A
90031	425	305	P	SMP734	N/A	E	110-110-125	N/A
90032	392	294	P	USE OE	N/A	E	110-110-115	N/A
90033	425	305	P	SMP734	N/A	E	110-110-125	N/A

Note: Bush kits with part numbers starting with SMP indicate the kits have the urethane bush, mounting nut & washers.

1. When remaining stock is exhausted no further product will be available.

cont.

See Shock Absorber Mout Types section for legend of mount types.

SPECIFICATIONS - SHOCK ABSORBERS

NITROCHARGER SPORT

Part Number	Open Length (mm)	Closed Length (mm)	Type	UPPER MOUNT BUSH KIT		Type	LOWER MOUNT BUSH KIT	
				Original Kit	Bushes only Replacement		Original Kit	Bushes only Replacement
90035	815	665	P	SMP719	N/A	CLEVIS	N/A	N/A
90036	815	665	P	SMP719	N/A	CLEVIS	N/A	N/A
90037	500	365	P	N/A	N/A	E	110-110-130	N/A
90038	490	380	P	SMP709	Use OE	E	110-110-135	N/A
90039	490	380	P	SMP709	Use OE	E	110-110-135	N/A
90040	515	353	P	N/A	N/A	E	110-800-556	N/A
90044	539	392	P	N/A	N/A	CLEVIS	N/A	N/A
90045	500	350	P	N/A	N/A	E	110-110-122	N/A
90046	500	350	P	N/A	N/A	E	110-110-122	N/A
90047	579	405	P	SMP755	N/A	T-PIN E	SMP755	N/A
90048	693	427	P	SMP709	N/A	E	SMP709	N/A
90052	555	386	P	OE	N/A	E	100-800-556	N/A
90053	555	386	P	OE	N/A	E	100-800-556	N/A
90054	620	445	P	OE	OE	E	110-110-143	N/A
90055	620	445	P	OE	OE	E	110-110-143	N/A
91005	613	432	P4124	OE	OE	E4066	110-110-110	N/A

Note: Bush kits with part numbers starting with SMP indicate the kits have the urethane bush, mounting nut & washers. See Shock Absorber Mount Types section for legend of mount types.

SPECIFICATIONS - SHOCK ABSORBERS

NITROCHARGERS

Part Number	Open Length (mm)	Closed Length (mm)	Type	UPPER MOUNT BUSH KIT		Type	LOWER MOUNT BUSH KIT	
				Original Kit	Bushes only Replacement		Original Kit	Bushes only Replacement
N15 ¹ /N15C ¹	517	327	E4005-S	110-034-072	N/A	E4005	110-034-070	OMEB36
N16	477	352	P4184	SMP374	OMEB42	E4078-T	SMP487	110034078
N17	632	382	E4026-T	SMP488	110034078	E4026-S	110-034-074 ¹	N/A
N18 ¹	340	225	P4169	SMP474	OMEB13	E4026-S	110-A42-074	OMEB10
N19/N19C ¹	492	292	P4184	SMP345	OMEB42	P4184	SMP345	OMEB42
N21 ¹	492	292	P4184	SMP345	OMEB42	P4184	SMP345	OMEB42
N22F ¹	656	396	E4005	SMP363	OMEB36	E4005	SMP363	OMEB40
N23F ¹	492	292	P4184	SMP345	OMEB42	P4184	SMP345	OMEB42
N25 ¹	642	377	E4005	SMP517 ¹	OMEB36	P4169	SMP474	OMEB13
N26F ¹	381	245	P4169	SMP474	OMEB13	E4026-S	N/A	OMEB10
N27 ¹	560	340	E4005	110-034-069 ¹	OMEB40	P4184	SMP683	SMP683
N28 ¹	504	309	P4169	SMP474	OMEB13	E4005	SMP343 ¹	OMEB36
N29 ¹ /N29C ¹	656	396	E4005	SMP363	OMEB36	E4005	SMP363	OMEB40
N30 ¹	618	368	E4001	110-034-065 ¹	OMEB14	E4001	110-034-065 ¹	OMEB14
N30E ¹	659	389	E4001	*110-034-065 ¹	OMEB14	E4001	110-034-065 ¹	OMEB14
N31S ¹	501	318	N/A	N/A	N/A	N/A	N/A	N/A
N32	500	315	P4169	SMP474	OMEB13	E4026-S	N/A	OMEB10
N33	625	365	P4169	SMP476	OMEB13	E4026-S	110-034-056	OMEB10
N34 ¹	509	329	E4001	110-034-065 ¹	OMEB14	E4026-S	110-034-056	OMEB10
N35 ¹ /N35C ¹	568	348	P4169	SMP476	N/A	E4026-T	110-110-088	110-110-088
N36 ¹ /N36C ¹	562	342	E4026-T	110-110-089	110-110-089	E4026-S	110-034-056	OMEB10
N37	591	366	E4040-S	110-110-054 ¹	N/A	E4040-S	110-110-054 ¹	N/A
N38S	473	339	P	N/A	N/A	E-B	N/A	N/A
N39 ¹ /N39C ¹	562	342	P4169	SMP476	SMP476	E4026-T	110-110-088	110-110-088
N40 ¹ /N40C ¹	556	336	E4003	110-034-076	N/A	E4026-S	110-034-056	OMEB10
N41 ¹	499	309	E4001	110-034-065 ¹	OMEB14	E4001	110-034-065 ¹	OMEB14
N42 ¹	594	359	E4001	110-034-065 ¹	OMEB14	E4001	110-034-065 ¹	OMEB14
N43	485	295	P4169	SMP474	OMEB13	E4001	110-034-065 ¹	OMEB14
N44 ¹	560	340	E4005	110-034-069 ¹	OMEB40	P4184	SMP683	SMP683
N45F ¹	554	324	P4184	SMP343 ¹	OMEB42	P4184	SMP343 ¹	OMEB42
N46 ¹	560	340	E4005	110-034-069 ¹	OMEB40	P4184	SMP683	SMP683
N47	406	251	P4169	SMP474	OMEB13	P4169	SMP474	OMEB13
N48	560	335	E4001	110-034-065 ¹	OMEB14	P4169	SMP474	OMEB13
N49	446	271	P4169	SMP474	OMEB13	P4169	SMP474	OMEB13
N50	584	349	P4169	SMP474	OMEB13	E4005	110-034-070	OMEB36
N51 ¹	365	235	P4169	SMP474	OMEB13	E4026-B5	110-034-181	110-034-181
N52 ¹ /N52F ¹	425	265	P4161	SMP334 ¹	N/A	E4026-S	110-A42-071 ¹	OMEB10
N53 ¹ /N53C ¹	628	378	E4040-B	110-004-040 ¹	N/A	E4026-S	110-034-181	110-034-181
N54 ¹	554	339	E4001	*110-034-065 ¹	OMEB14	E4001	110-034-065 ¹	OMEB14
N55 ¹	585	345	P4161	SMP334 ¹	N/A	E4026-S	110-A42-071 ¹	OMEB10
N56 ¹	554	339	E4001	*SMP516	OMEB14	E4001	SMP516	OMEB14
N57G ¹	340	225	P4169	SMP474	OMEB13	E4026-S	N/A	OMEB10
N58 ¹	325	215	P4169	SMP474	OMEB13	E4026-S	N/A	OMEB10
N59 ¹	559	339	E4001	*SMP516	OMEB14	E4001	SMP516	OMEB14
N60G ¹	340	225	P4169	SMP474	OMEB13	E4026-T	110-110-078	110034078
N61/N61C ¹	607	367	E4005-S	SMP363	OMEB17	E4026-S	110-034-056	OMEB10
N62G ¹	507	317	E4001	110-034-065 ¹	OMEB14	E4005-S	110-034-077 ¹	OMEB17
N63G ¹	478	299	P4169	SMP474	OMEB13	E4005-S	110-034-077 ¹	OMEB17
N64 ¹ /N64C ¹	478	299	P4169	SMP474	OMEB13	E4005-S	110-034-077 ¹	OMEB17
N65 ¹	385	245	P4169	SMP474	OMEB13	E4026-S	110-A42-074	OMEB10
N66 ¹ /N66C ¹	568	335	P4169	SMP476	N/A	E4026-TB	110-110-088	N/A
N67 ¹	562	339	E4026-TB	110-110-089	N/A	E4026-S	110-034-056	OMEB10

Note: Bush kits with part numbers starting with SMP indicate the kits have the urethane bush, mounting nut & washers.

1. When remaining stock is exhausted no further product will be available.

*Spacer Kit SMP511 also supplied.

See Shock Absorber Mout Types section for legend of mount types.

cont.

SPECIFICATIONS - SHOCK ABSORBERS

NITROCHARGERS

Part Number	Open Length (mm)	Closed Length (mm)	Type	UPPER MOUNT BUSH KIT		Type	LOWER MOUNT BUSH KIT	
				Original Kit	Bushes only Replacement		Original Kit	Bushes only Replacement
N68 ¹	640	384	E4005	110-034-070	OMEB15	E4005	110-034-070	OMEB15
N68E ¹	660	394	E4005	110-034-070	OMEB15	E4005	110-034-070	OMEB15
N69	470	290	E4005	110-034-070	OMEB36	P4184	SMP343 ¹	OMEB42
N70 ¹	614	354	P4184	SMP403 ¹	OMEB42	P4184	SMP403 ¹	OMEB42
N71E ¹	620	370	P4184	SMP403 ¹	OMEB42	E4005	110-034-070	OMEB36
N72F ¹	548	329	P4169	SMP474	OMEB13	E4005	110-034-070	OMEB36
N73 ¹	614	354	P4184	SMP501	OMEB42	P4184	SMP501	OMEB42
N74E ¹	620	370	P4184	SMP501	OMEB42	E4005	110-034-070	OMEB36
N75 ¹	640	390	E4005	110-034-070	OMEB15	E4005	110-034-070	OMEB15
N75E ¹ /N75F ¹	652	397	E4005	110-034-070	OMEB15	E4005	110-034-070	OMEB15
N76	685	408	E4005	110-034-070	OMEB15	E4005	110-034-070	OMEB15
N77 ¹	570	340	E4032-S	110-110-077	N/A	P4169	SMP474	OMEB13
N78	447	287	E4005	110-034-070	OMEB15	E4005	110-034-070	OMEB15
N79 ¹	507	307	E4005	110-034-070	OMEB36	P4169	SMP474	OMEB13
N80 ¹	352	232	P4169	SMP474	OMEB13	E4005-S	110-034-072	OMEB17
N81	499	309	E4001	110-034-065 ¹	OMEB14	E4001	110-034-065 ¹	OMEB14
N83 ¹	345	225	P4169	SMP474	OMEB13	E4026-S	SMP381	OMEB10
N84 ¹	485	295	P4169	SMP474	OMEB13	E4026-S	N/A	OMEB10
N85 ¹	587	357	E4005	110-034-070	OMEB15	E4005	110-034-070	OMEB15
N86 ¹ /N86C ¹	539	329	P4169	SMP474	OMEB13	E4005	110-034-070	OMEB15
N87 ¹	352	232	P4169	SMP474	OMEB13	E4005-S	110-034-072	OMEB17
N88 ¹	589	349	P4169	SMP474	OMEB13	E4005	110-034-070	OMEB36
N89 ¹	594	359	E4001	**110-034-065 ¹	OMEB14	E4001	110-034-065 ¹	OMEB14
N90 ¹	582	357	E4005	110-034-070	OMEB15	E4005	110-034-070	OMEB15
N91S ¹	470	335	P-	SMP415	N/A	E4050-B	110-110-122	110-110-122
N91SC ¹	470	335	P-	SMP415	N/A	E4050-B	110-110-122	110-110-122
N92 ¹	589	349	P4169	SMP474	OMEB13	E4005	110-034-070	OMEB36
N93 ¹	485	295	P4169	SMP474	OMEB13	E4026-S	N/A	OMEB10
N94 ¹	587	357	E4005	110-034-070	OMEB15	E4005	110-034-070	OMEB15
N95 ¹	599	359	E4001	**110-034-065 ¹	OMEB14	E4001	110-034-065 ¹	OMEB14
N96	431	261	P4169	SMP474	OMEB13	P4169	SMP474	OMEB13
N97	545	325	E4001	110-034-065 ¹	OMEB14	P4169	SMP474	OMEB13
N98 ¹	389	249	P4169	SMP474	OMEB13	E4005-S	110-034-072	OMEB17
N100 ¹	440	290	P4203	SMP493	N/A	E4050-BS	110-110-122	110-110-122
N101 ¹ /N101C ¹	610	360	P4204	SMP493	SMP493	E4005	110-034-069 ¹	OMEB40
N102 ¹	482	302	P4169	SMP474	OMEB13	E4050-BS	110-110-122	N/A
N103S	504	318	P-	N/A	N/A	N/A	N/A	N/A
N104/N104C ¹	641	391	E4040-S	110-110-054 ¹	N/A	E4055-S	110-110-069 ¹	N/A
N105	508	318	P4169	SMP474	OMEB13	E4026-S	110-004-074 ¹	OMEB10
N106 ¹ /N106C ¹	537	317	P4184	SMP501	OMEB42	P4184	SMP501	OMEB42
N107 ¹ /N107C ¹	608	373	E4005-S	110-110-066	N/A	E4005-T	110-110-067	N/A
N108 ¹ /N108C ¹	593	363	E4005-S	110-110-066	N/A	E4005-BS	110-110-066	110-110-066
N109S ¹	472	327	N/A	Use OE Bushes	N/A	E4055BS	110-110-075	N/A
N110 ¹	575	350	P4158	SMP641	N/A	E4040-BS	110-110-076	N/A
N111 ¹	548	328	P4170	SMP312	N/A	E4026-S	SMP487	N/A
N112 ¹	449	279	P4169	SMP474	OMEB13	E4005	110-034-070	OMEB15
N113 ¹	537	337	E4005	110-034-070	OMEB15	E4005	110-034-070	OMEB15
N114 ¹	475	285	P4184	SMP345	OMEB42	P4184	SMP345	OMEB42
N115 ¹	554	324	P4184	SMP374	OMEB42	P4184	SMP374	OMEB42
N116 ¹	527	327	E4001	110-034-065 ¹	OMEB14	E4005-S	110-034-072	OMEB17
N117 ¹	578	358	E4057-S	110-110-085	N/A	E4001-T	110-034-020 ¹	OMEB10
N118	532	322	P4169	SMP474	OMEB13	E4005	110-034-080	OMEB11

Note: Bush kits with part numbers starting with SMP indicate the kits have the urethane bush, mounting nut & washers.

1. When remaining stock is exhausted no further product will be available.

* Spacer Kit SMP495 supplied.

See Shock Absorber Mout Types section for legend of mount types.

cont.

SPECIFICATIONS - SHOCK ABSORBERS

NITROCHARGERS

Part Number	Open Length (mm)	Closed Length (mm)	Type	UPPER MOUNT BUSH KIT		Type	LOWER MOUNT BUSH KIT	
				Original Kit	Bushes only Replacement		Original Kit	Bushes only Replacement
N119S ¹	596	395	N/A	SMP483 ¹	SMP483 ¹	N/A	N/A	N/A
NC120 ¹	609	402	N/A	110-039-058 ¹	110039058 ¹	N/A	N/A	N/A
N121S ¹	576	389	N/A	SMP483 ¹	SMP483 ¹	N/A	N/A	N/A
NC122 ¹	589	402	N/A	110-039-058 ¹	110039058 ¹	N/A	N/A	N/A
N123S ¹	596	395	N/A	SMP483 ¹	SMP483 ¹	N/A	N/A	N/A
N124S ¹	576	389	N/A	SMP483 ¹	SMP483 ¹	N/A	N/A	N/A
N125S ¹	411	289	P	SMP363	SMP363	N/A	N/A	N/A
N126S ¹	411	289	P	SMP363	SMP363	N/A	N/A	N/A
N127S ¹	601	385	P	SMP354 ¹	SMP354 ¹	E-BS	N/A	N/A
N128 ¹	358	238	P4205	SMP474	OMEB13	E4026-T	SMP489 ¹	N/A
N129S ¹	472	327	P	Use OE Bushes	N/A	E4055-BS	110-110-075	110-110-075
N129S ¹ (10/15 on)	472	327	P	Use OE Bushes	N/A	E4055-BS	110-110-125	110-110-125
NS130 ¹	333	201	P	SMP725	SMP725	N/A	N/A	N/A
NS131 ¹	333	201	P	SMP725	SMP725	N/A	N/A	N/A
N132 ¹	573	359	E4057-S	110-110-085	N/A	E4005-S	110-110-086 ¹	N/A
N133 ¹	443	287	P4203	SMP493	SMP493	E4050-BS	110-110-122	110-110-122
N134 ¹	559	349	E4057-S	110-110-085	N/A	E4005-S	110-110-086 ¹	N/A
N135S ¹ /N136S ¹	602	393	P	SMP483 ¹	SMP483 ¹	N/A	N/A	N/A
NC138 ¹	609	400	P	SMP546 ¹	N/A	-	-	-
N139S ¹	543	405	P	SMP633/626	N/A	E4050-S	110-110-122	110-110-122
N140S ¹	543	405	P	SMP633/626	N/A	E4050-S	110-110-122	110-110-122
N141 ¹	577	353	P4184	SMP569	N/A	E4005	SMP621	OMEB40
N142 ¹	577	353	P4184	SMP569	N/A	E4005	SMP621	OMEB40
N143S ¹	590	408	P	-	N/A	-	-	N/A
N144S ¹	590	408	P	-	N/A	-	-	N/A
NC145 ¹	651	439	P	SMP625 ¹	N/A	-	-	N/A
N145S ¹	593	405	N/A	SMP622	N/A	N/A	N/A	N/A
N146 ¹	655	379	P	SMP641	N/A	E4055-BS	110-110-093 ¹	N/A
N146S ¹	593	405	N/A	SMP622	N/A	N/A	N/A	N/A
N147S	476	362	P	SMP640	N/A	E4050-S	110-110-122	110-110-122
N148S ¹	476	362	P	SMP640	N/A	E4050-S	110-110-122	110-110-122
N149	504	313	E4051-BS	110-110-092 ¹	N/A	E4051-BS	110-110-092 ¹	N/A
N150 ¹	388	242	P4205	SMP474	OMEB13	E4026-S	110-A42-074	OMEB10
N151 ¹	308	202	P4205	SMP474	OMEB13	E4026-S	110-A42-074	OMEB10
N152 ¹	576	345	P4158	SMP641	N/A	E4051-BS	110-110-076	N/A
N153 ¹	528	312	P4205	SMP474	OMEB13	E4026-S	110-034-074 ¹	OMEB10
N154 ¹	562	336	E4001	110-034-065 ¹	OMEB14	E4001	110-034-065 ¹	OMEB14
N155 ¹	568	332	P4205	SMP474	OMEB13	E4001	110-034-065 ¹	OMEB14
N156S ¹	365	530	-	Nut only	OEM	N/A	OEM	OEM
N157S ¹	365	530	-	Nut only	OEM	N/A	OEM	OEM
N158S ¹	405	610	-	Nut only	OEM	N/A	OEM	OEM
N159S ¹	405	610	-	Nut only	OEM	N/A	OEM	OEM
NC160 ¹	601	403	P	SMP546 ¹	SMP546 ¹	N/A	N/A	N/A
NC161 ¹	572	386	P	SMP625 ¹ & 633	SMP625 ¹ & 633	N/A	N/A	N/A
N162 ¹	348	222	P4205	SMP474	OMEB13	E4026-S	110-A42-074	OMEB10
NC163 ¹	617	386	P	SMP625 ¹ & 633	SMP625 ¹ & 633	N/A	N/A	N/A
N164 ¹	527	317	P4184	SMP501	OMEB42	P4184	SMP501	OMEB42
N165 ¹	657	397	E4005	110-034-070	OMEB15	E4005	110-034-070	OMEB15
N166S ¹	543	411	P	SMP633 & 626	SMP633 & 626	E4050-S	110-110-122	110-110-122
N167S ¹	543	411	P	SMP633 & 626	SMP633 & 626	E4050-S	110-110-122	110-110-122
N168 ¹	600	370	E4005	SMP649	SMP649	E4005	SMP649	SMP649
N169 ¹	600	370	E4005	SMP649	SMP649	E4005	SMP649	SMP649

Note: Bush kits with part numbers starting with SMP indicate the kits have the urethane bush, mounting nut & washers.

1. When remaining stock is exhausted no further product will be available.

See Shock Absorber Mout Types section for legend of mount types.

cont.

SPECIFICATIONS - SHOCK ABSORBERS

NITROCHARGERS

Part Number	Open Length (mm)	Closed Length (mm)	Type	UPPER MOUNT BUSH KIT		Type	LOWER MOUNT BUSH KIT	
				Original Kit	Bushes only Replacement		Original Kit	Bushes only Replacement
N170 ¹	348	322	P4205	SMP474	OMEB13	E4026-S	110-A42-074	OMEB10
N171 ¹	532	316	P4205	SMP474	OMEB13	E4005	SMP650 ¹	OMEB15
N172 ¹	532	316	P4205	SMP474	OMEB13	E4005	SMP650 ¹	OMEB15
N173S ¹	481	301	P	N/A	N/A	-	N/A	N/A
N174 ¹	597	341	P4180	SMP343 ¹	SMP343 ¹	P4180	SMP343 ¹	SMP343 ¹
N175 ¹	603	363	E4005	110-034-063 ¹	OMEB36	P4180	SMP343 ¹	SMP343 ¹
N176	535	319	E4055-S	110-110-066	N/A	P4180	SMP343 ¹	SMP343 ¹
N177	485	299	E4055-S	110-110-066	N/A	P4180	SMP343 ¹	SMP343 ¹
N178	600	364	E4005	110-034-082	110-034-082	E4005-S	110-A42-124 ¹	OMEB11
N179	790	456	E4005	110-034-083	110-034-083	E4005-S	110-A42-124 ¹	OMEB11
N180	690	406	E4005	110-034-082	110-034-082	E4005-S	110-A42-124 ¹	OMEB11
N181 ¹	537	317	P4184	SMP501	OMEB42	P4184	SMP501	OMEB42
N182 ¹	608	352	P4205	SMP474	OMEB13	E4026-S	110-A42-074	N/A
N183S ¹	390	281	P-	SMP633	N/A	E4063-BS	110-110-100	N/A
N183S ¹ (2/11 on)	390	281	P-	SMP633	N/A	E4063-BS	110-110-112	N/A
N184 ¹	379	255	E4051-S	110-110-076	N/A	E4051-S	110-110-076	N/A
N185 ¹	567	341	E4001	110-043-065 ¹	OMEB14	E4063-S	110-110-100	N/A
N186S ¹	426	298	P-	N/A	N/A	E4055-BS	110-110-125	N/A
N187 ¹	360	240	P4205	SMP475 ¹	OMEB13	E4050	TBA	110-034-181
N188S	-	-	-	-	-	-	-	-
N189 ¹	600	360	E4005	110-034-070	OMEB15	E4005BS	110-034-080	-
N190	658	394	E4057-S	110-110-085	N/A	E4005-S	110-110-086 ¹	-
N191 ¹	589	349	P4205	SMP474	OMEB13	E4005-S	110-034-070	OMEB15
N192S	589	424	P-	SMP659 ¹	SMP659 ¹	E4055-BS	110-110-101	-
N193	661	391	P4203	SMP493	-	E4040-BS	110-110-102 ¹	N/A
N194 ¹	360	240	P4205	SMP475 ¹	OMEB13	E4050	TBA	110-034-181
N195	560	340	P4204	SMP493	-	E4051-S	110-110-103	-
N196 ¹	576	348	P4184	SMP374	OMEB42	E-TBA	TBA	TBA
N197 ¹	652	397	E4005	110-034-070	OMEB15	E-4005	110-034-070	OMEB15
N198 ¹	615	375	E-TBA	TBA	TBA	E-TBA	TBA	TBA
N199 ¹	440	290	P4203	SMP493	SMP493	E4050-BS	110-110-122	110-110-122
N200 ¹	610	360	P4204	SMP493	SMP493	E4005	110-034-069 ¹	OMEB40
N201S ¹	543	405	P-	SMP633/626	N/A	E4050-S	110-110-122	110-110-122
N202 ¹	577	353	P4184	SMP569	SMP569	E4005	SMP621	OMEB40
N203S ¹	472	327	P	Use OE Bushes	N/A	E4055-BS	110-110-075	110-110-125
N204 ¹	576	345	P4158	SMP641	N/A	E4051-BS	110-110-076	N/A
N205	507	312	P4213	SMP665 ¹	N/A	E4051-BS	110-110-092 ¹	N/A
N206S ¹	602	399	P-	Nut only	N/A	N/A	N/A	N/A
N207S ¹	602	399	P-	Nut only	N/A	N/A	N/A	N/A
N208S ¹	608	433	P4214	OE	OE	E4066	110-110-110	110-110-110
N209 ¹	610	360	P4204	SMP493	N/A	E4005	110-034-063 ¹	OMEB40
N210 ¹	610	360	P4204	SMP493	N/A	E4005	110-034-063 ¹	OMEB40
N211 ¹	576	348	P4184	SMP374	OMEB42	E4026	110-034-181	110-034-181
N212 ¹	618	375	E4053	110-110-105 ¹	N/A	E4026	110-034-181	110-034-181
N217S	610	395	P-	N/A	N/A	N/A	N/A	N/A
N218S	610	395	P-	N/A	N/A	N/A	N/A	N/A
N219S	516	357	P	Use OE Bushes	N/A	OEM	OEM	N/A
N220	658	394	E4057-S	110-110-085	N/A	E4005-S	110-110-086 ¹	N/A
OME007 ¹	600	359	E4004	110-034-003 ¹	N/A	E4003	110-034-003 ¹	N/A
OME013	473	292	E4001	110-034-071	OMEB14	E4001	110-034-071	OMEB14
OME014 ¹	495	305	E4001	110-034-071	OMEB14	E4001	110-034-071	OMEB14
OME015 ¹	415	256	P4175	SMP333 ¹	OMEB13	E4001	110-034-071	OMEB14

Note: Bush kits with part numbers starting with SMP indicate the kits have the urethane bush, mounting nut & washers.

1. When remaining stock is exhausted no further product will be available.

See Shock Absorber Mout Types section for legend of mount types.

cont.

SPECIFICATIONS - SHOCK ABSORBERS

NITROCHARGERS

Part Number	Open Length (mm)	Closed Length (mm)	Type	UPPER MOUNT BUSH KIT		Type	LOWER MOUNT BUSH KIT	
				Original Kit	Bushes only Replacement		Original Kit	Bushes only Replacement
OME018 ¹	585	359	E4003	110-034-003 ¹	N/A	E4003	110-034-003 ¹	N/A
OME023 ¹	429	270	E4001	110-034-071	OMEB14	E4001	110-034-071	OMEB14
OME025	415	256	P4175	SMP333 ¹	OMEB13	E4001	110-034-071	OMEB14
OME027 ¹	497	297	P4175	SMP333 ¹	OMEB13	E4001	110-034-071	OMEB14
OME028	450	281	P4169	SMP474	OMEB13	E4028-S	110110009	N/A
OME029	502	314	E4028-S	110110009	N/A	E4028-S	110110009	N/A
OME030 ¹	470	302	E4028-S	110110009	N/A	E4028-S	110110009	N/A
OME031	627	379	P4175	SMP333 ¹	OMEB13	E4001	110-034-071	OMEB14
OME032 ¹	608	369	P4175	SMP333 ¹	OMEB13	E4001	110-034-071	OMEB14
OME033 ¹	615	382	P-	SMP636	OMEB13	E4005-S	110-034-072	OMEB17
OME034	481	284	P4175	SMP333 ¹	OMEB13	E4001	110-034-071	OMEB14
OME035	495	299	E4001	110-034-071	OMEB14	E4001	110-034-071	OMEB14
OME036	560	335	E	06082183 ¹	N/A	E	06082183 ¹	N/A

Note: Bush kits with part numbers starting with SMP indicate the kits have the urethane bush, mounting nut & washers.

1. When remaining stock is exhausted no further product will be available.
See Shock Absorber Mout Types section for legend of mount types.

SPECIFICATIONS - SHOCK ABSORBERS

SHOCK ABSORBER MOUNT TYPES

Mount Type Pin Part No.	Dimensions (mm) Thread Length X Dia.	OME Replacement Part No.
P4161	62 x M10 x 1.5	OMEB13
P4169	53 x M10 x 1.25	OMEB13
P4170	73 x M10 x 1.5	OMEB13
P4175	58 x M10 x 1.5	OMEB13
P4184	71 x M12 x 1.25	OMEB42
P4203	85 x M14 x 1.5	Use original
P4204	77 x M14 x 1.5	Use original
P4205	54 x M10 x 1.25	OMEB13

Mount Type Eye Part No.	Dimensions (mm) OD x ID x L	Mounting Kit Replacement Part No.
E4001	37 x 25.3 x 24.3	OMEB14
E4003	42.6 x 37.7 x 19.5	Not available
E4005	44.2 x 31.7 x 30	OMEB36 *OMEB40
E4026	37 x 27 x 25	OMEB10
E4028	38.4 x 25.1 x 23	Not available
E4032	46.7 x 36.6 x 33	Not available
E4040	46 x 37 x 30	Not available
E4050	45 x 39 x 35	Not available
E4055	50 x 40.2 x 34	Not available
E4057	42 x 32.5 x 29	Not available

T-CROSS PIN MOUNTING

S-BUSH WITH SLEEVE

B-BONDED BUSH

*Special Bush for N22F¹, N29¹/N29C¹ Lower Rear Mount

1. When remaining stock is exhausted no further product will be available.

SPECIFICATIONS - TORSION BARS

TORSION BARS

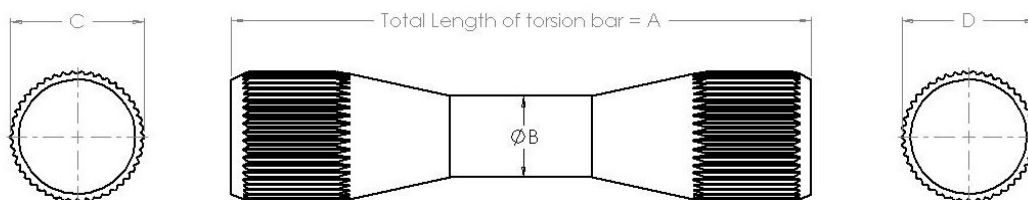

Part Number	A ± 2.0	B ± 0.15	C +0 -0.2	C Spline No.	D +0 -0.2	D Spline No.
303001	1160	30.4	47.0	46	47.0	46
303002	1210	32.8	47.0	46	47.0	46
303003	1065	23.4	33.0	43	30.75	40
303004	1000	24.5	33.0	43	33.0	43
303005	925	25.7	30.75	40	30.75	40
303006	1365	27.5	30.0	39	30.75	40
303007	890	26.7	30.0	39	30.0	39
303008	1205	26.0	30.0	39	30.0	39
303009	1277.5	25.5	30.0	39	30.75	40
303010	1277.5	27.3	30.0	39	30.75	40
303011	1307.5	27.5	30.0	39	30.75	40
303012	1142	26.0	36.0	47	36.0	47
303013	1024	27.0	30.75	40	30.75	40
¹ 303014	1225	30.3	37.85	6 side hex	37.85	6 side hex

All dimensions in millimetres (mm)

1. When remaining stock is exhausted no further product will be available.

SPECIFICATIONS - STABILISERS

STEERING STABILISERS

Part Number	Upper Mount Type (mm)	Lower Mount Type (mm)	Open Length (mm)	Closed Length (mm)	Mounting Kit No.	No. of Kits	OME Bush Kit
OMESD01	Eye with Bush	Eye with Bush	552	342	142995	1	
OMESD02	Eye with Bush & Sleeve	Eye with Bush & Sleeve	655	394	No Kit		
OMESD11	Pin 60 x 9.5	Pin 60 x 9.5	516	308	140276	1	
OMESD16 ¹	Pin 60 x 9.5	Pin 60 x 9.5	535	314	140276	1	
OMESD17 ¹	Eye with Bush	Eye with Bush	622	373	142387	1	
OMESD21	Pin 60 x 9.5	Eye with Bush	542	340	140504	1	
OMESD22	Eye with Bush	Eye with Bush	537	328	No Kit		OMEB14
OMESD23	Eye with Bush	Eye with Bush	454	316	142995	1	
OMESD24	Eye with Bush	Eye with Bush	651	417	142995	1	
OMESD30	Eye with Bush & Sleeve	Eye with Bush & Sleeve	448	290	No Kit		
OMESD31 ¹	Eye with Bush & Sleeve	Eye with Bush & Sleeve	577	392	No Kit		
OMESD32	Pin 60 x 9.5	Eye with Bush & Sleeve	680	440	500555	1	
OMESD33	Eye with Bush & Mounting Pin	Eye with Bush	611	364	140953	1	
OMESD34	Eye with Bush & Sleeve	Eye with Bush	575	347	No Kit		
OMESD35 ¹	Eye with Bush & Sleeve	Eye with Bush & Sleeve	503	311	No Kit		
OMESD36	Pin 60 x 9.5	Pin 60 x 9.5	484	289	140276	1	
OMESD40	Eye with Bush	Eye with Bush & Sleeve	499	309	500498	1	
OMESD47	Eye with Bush	Eye with Bush	750	510	142995	1	
OMESD48	Eye with Bush	Eye with Bush & Sleeve	499	310	500498	1	142864 (Boot)

1. When remaining stock is exhausted no further product will be available.

RECOMMENDED FITTING TIMES

COIL SPRINGS SYSTEMS

All Coil Spring Models (Except Land Rovers) Fitment of 4 Shock Absorbers & 4 OME coil springs	2.0 hours
Land Rover All Coil Spring Models Fitment of all the above plus additional time to remove front shock absorber towers	3.0 hours
Torsion Bar Front with Rear Coil Suspension Fitment of 4 Shock Absorbers, 2 OME coil springs & front torsion bar adjustment	2.0 hours
Coil Front with Rear Leaf Suspension Fitment of 4 Shock Absorbers, 2 OME coil springs & 2 OME leaf springs	3.5 hours
Coil Over Front Strut with Rear Coil Suspension Fitment of 2 Shock Absorbers, 2 OME struts & 4 OME coil springs	3.0 hours
Coil over Front Strut with Leaf Rear Springs Fitment of 2 Shock Absorbers, 2 struts, 2 coils & 2 leaf Springs	4.5 hours

LEAF SPRING SYSTEMS

All Leaf spring Models (Except HiLux) Fitment of 4 Shock Absorbers, 4 OME leaf springs, and U bolts and spring bushes as required	5.0 hours
Toyota HiLux All Leaf Spring Models Fitment of all the above plus additional work required to strengthen front spring seat mount	6.0 hours
Front Torsion Bar with Rear Leaf Spring Models Fitment of 4 Shock Absorbers, 2 OME rear leaf springs, U bolts, spring bushes and front torsion bar adjustment	3.0 hours

CARTRIDGE REPLACEMENT

Additional work required to install cartridge per strut	0.5 hours
---------------------------------------------------------	-----------

TORSION BARS

Remove and replace a set of bars (no removal complications)	1.5 hours
Remove and replace a set of bars (removal complications eg. OE splines corroded)	2.5 hours

MISCELLANEOUS

Caster kits	2.0 hours
Steering stabilisers	0.5 hours
Greasable shackles per set of springs	1.0 hours
Greasable pin per set of springs	0.5 hours

FRONT END WHEEL ALIGNMENT ADJUSTMENTS

	JDE PART #
Live axle front end	WHAL
Independent front end	WHALIFS
Independent rear end	WHALIFS

The above fitting times are only a guide, and additional time may be involved due to vehicle modifications or pre-existing accessories which can interfere with the fitment of the suspension.

FIT TIMES BY VEHICLE

Make	Model	Springs, shocks/ struts & shackles/ pins/fit kits	Bp Fit Kit	Caster Kit	Steering Stabiliser	Comments
Chrysler	Grand Cherokee WK2	3.0 hrs				
	Grand Cherokee WH & WK	3.0 hrs				
	Grand Cherokee WJ & WG	3.0 hrs				Add 1 hr if fitting OMESTAB1
	Grand Cherokee ZJ	3.0 hrs			0.5 hr	
	Commander XK	3.0 hrs				
	Cherokee XJ Wagon	3.5 hrs			0.5 hr	
	Cherokee/Liberty KK	3.0 hrs				
	Cherokee/Liberty KJ	3.0 hrs				
	Wrangler TJ	3.0 hrs			0.5 hr	
	Wrangler YJ	5.0 hrs			0.5 hr	
	Wrangler JL	2.0 hrs	1.0 hr	1.0 hr	0.5 hr	2 inch lift
	Wrangler JK	2.0 hrs	1.0 hr	1.0 hr	0.5 hr	2 inch lift
	Dodge RAM 1500 DS	3.0hrs				
Ford	Ranger 2022 on	4.5 hrs	1.0 hr			
	Ranger PX 1,2,3	4.5 hrs	1.0 hr			
	Ranger PJ/PK	4.0 hrs				
	Ranger Raptor	3.0 hrs				
	Bronco LWB 2021 On	4.0 hrs				
	Courier/Ranger 1 tonne	4.0 hrs				
	Everest	3.0 hrs				
	F250/F350 2011 to 2017	7.0 hrs				Includes all bracket kits
	F250/F350 2008 to 2010	7.0 hrs				Includes all bracket kits
	F250/F350 2005 to 2008	3.5 hrs		1.0 hr		
F250/F350 1999 to 2004	5.0 hrs					
Holden/Isuzu/GM	Jackaroo 2001 to 2004	2.0 hrs				
	Jackaroo 1992 to 2001	2.0 hrs				
	Jackaroo 1982 to 1992	4.0 hrs				
	Frontera 1999 to 2003	2.0 hrs				
	Frontera 1995 to 1998	2.0 hrs				
	MUX 2021 on	3.0 hrs				
	Trailblazer/Colorado 7/MUX to 20	3.0 hrs				
	Colorado/Canyon 2015 on	4.5 hrs				
	Dmax 2021 on	4.5 hrs	1.0 hr			
	Dmax 12 to 20/Colorado 12 on	4.5 hrs	1.0 hr			
	Dmax/Colorado/Rodeo	4.0 hrs				
	Rodeo/Dmax to 2003	4.0 hrs				
	Drover	5.0 hrs			0.5 hr	
Hummer	H3	4.0 hrs				
Hyundai	Terracan	2.0 hrs				
Kia	Sorrento	3.0 hrs				
Lada	Niva	2.0 hrs				
Land Rover	Discovery 3	3.0 hrs				
	Discovery 1999 to 2004	3.0 hrs			0.5 hr	
	Discovery/Range Rover	3.0 hrs		2.0 hrs	0.5 hr	
	Defender 110	3.0 hrs		2.0 hrs	0.5 hr	
	Defender 110 long travel	4.0 hrs	2.0 hrs	2.0 hrs	0.5 hr	
	Defender 130	3.0 hrs		2.0 hrs	0.5 hr	
	90 series	3.0 hrs		2.0 hrs	0.5 hr	
Mazda	BT-50 2021 on	4.5 hrs	1.0 hr			
	BT-50 2011 to 2020	4.5 hrs	1.0 hr			
	BT-50 1 tonne 2006 to 2011	4.0 hrs				
	B Series 1 tonne 1987 to 2006	4.0 hrs				
Mercedes	G Wagon	2.0 hrs				
Mitsubishi	Pajero Sport 2015 on	3.0 hrs				
	Pajero/Montero 2007 on	3.0 hrs				
	Pajero/Montero 2000 to 2006	3.0 hrs				
	Pajero/Montero 1991 to 1999	4.0 hrs				Leaf Spring rear
	Pajero/Montero 1991 to 1999	3.0 hrs				Coil Spring rear
	Pajero/Montero to 1991	4.0 hrs				

cont.

FIT TIMES BY VEHICLE

Make	Model	Springs, shocks/ struts & shackles/ pins/fit kits	Bp Fit Kit	Caster Kit	Steering Stabiliser	Comments
Mitsubishi (cont.)	Pajero Challenger 1989 to 1991	3.0 hrs				
	Triton/L200 MR & MQ	4.5 hrs				
	Triton/L200 ML & MN	4.5 hrs				
	Triton/L200 MK	4.0 hrs				
	Triton/L200 to 1996	3.0 hrs				
	Challenger 2010 to 2015	3.0 hrs				
	Challenger 2000 to 2008	3.0 hrs				
	Challenger 1998 to 2000	4.0 hrs				
Nissan	Patrol Y62	3.0 hrs	1.0 hr			
	GU Patrol	2.0 hrs	1.0 hr	2.0 hrs	0.5 hr	Coil/Coil
	GU Patrol	3.5 hrs		2.0 hrs	0.5 hr	Coil Leaf
	GQ Patrol	2.0 hrs	1.0 hr	2.0 hrs	0.5 hr	Coil/Coil
	GU Patrol	5.0 hrs			0.5 hr	Leaf/Leaf
	MQ 260 Patrol	5.0 hrs				
	MQ M60 Patrol	5.0 hrs			0.5 hr	
	Navara NP300 15 on S1, 2, 3, 4, 5	3.0 hrs				Coil Spring rear
	Navara NP300 15 on S1, 2, 3, 4, 5	4.5 hrs				Leaf Spring rear
	Navara D40	4.0 hrs				
	Navara D22	4.0 hrs				
	Navara D21	4.0 hrs			0.5 hr	
	Pathfinder R51	3.0 hrs				
	Pathfinder R50	3.0 hrs				
	Pathfinder to 1995	2.0 hrs				
	Terrano	2.0 hrs				
Xterra	4.0 hrs					
Ssangyong	Musso 1995 to 2005	2.0 hrs				
Suzuki	Grand Vitara 2005 to 2015	3.0 hrs				
	Grand Vitara to 2005	3.0 hrs				
	Vitara Wagon 1988 to 2005	3.0 hrs				
	Vitara Wagon 1988 to 2005	3.0 hrs				
	XL7	3.0 hrs				
	Equator	4.0 hrs				
	Sierra/Samurai	5.0 hrs			0.5 hr	
	Santana Samurai	5.0 hrs			0.5 hr	
	Jimny 2018 on	2.0 hrs		2.0 hrs		
Jimny to 2017	2.0 hrs					
Toyota	300 Series	3.0 hrs	1.0 hr			
	200 Series	3.0 hrs	1.0 hr			
	100 Series IFS	3.0 hrs				
	105 Series / 80 Series	2.0 hrs	1.0 hr	2.0 hrs	0.5 hrs	
	Prado 150	3.0 hrs	1.0 hr			
	Prado 120	3.0 hrs	1.0 hr			
	Prado 90	3.0 hrs				
	Tundra	4.5 hrs	1.0 hr			
	FJ Cruiser	3.0 hrs	1.0 hr			
	Fortuner	3.0 hrs				
	70 Series Dual Cab	3.5 hrs	1.0 hr	2.0 hrs	0.5 hr	Add 1 hr if fitting OMESTAB9
	76 Series Wagon	3.5 hrs	1.0 hr	2.0 hrs	0.5 hr	
	78 Series	3.5 hrs	1.0 hr	2.0 hrs	0.5 hr	Add 1 hr if fitting OMESTAB9
	79 Series Single Cab	3.5 hrs	1.0 hr	2.0 hrs	0.5 hr	Add 1 hr if fitting OMESTAB9
	75 Series	5.0 hrs			0.5 hr	
	HZJ71 & HZJ74	3.5 hrs		2.0 hrs	0.5 hr	
	Landcruiser 11 Wagon	2.0 hrs				
	Bundera RJ70	2.0 hrs				
	70, 73, 74 Series	5.0 hrs			0.5 hr	
	60, 61, 62 Series	5.0 hrs			0.5 hr	
45, 47 Series	5.0 hrs			0.5 hr		
40, 42 Series	5.0 hrs			0.5 hr		
Tacoma 2016 on	4.5 hrs	1.0 hr				

cont.

FIT TIMES BY VEHICLE

Make	Model	Springs, shocks/ struts & shackles/ pins/fit kits	Bp Fit Kit	Caster Kit	Steering Stabiliser	Comments
Toyota (cont.)	Tacoma 2005 to 2015	4.5 hrs	1.0 hr			
	Tacoma 1998 to 2004	4.0 hrs				
	Hilux 2015 on	4.5 hrs	1.0 hr			
	Hilux 2005 to 2015	4.5 hrs	1.0 hr			
	Hilux/Tiger 1997 to 2004	4.0 hrs			0.5 hr	
	Hilux and 4Runner Pre 1997	6.0 hrs			0.5 hr	All Leaf models
	Hilux Pres 1997 EC and DC SR5	4.0 hrs			0.5 hr	IFS front, leaf rear
	4 Runner 2010 on US model	3.0 hrs	1.0 hr			
	4 Runner 2003 to 2010 US model	3.0 hrs				
	4 Runner/Surf 1996 to 2002 US	3.0 hrs				
	4 Runner 1990 to 1996	3.0 hrs			0.5 hr	IFS front, coil rear
	4 Runner 1986 to 1990	4.0 hrs			0.5 hr	IFS front, leaf rear
	Volkswagen	Amarok 2010 on	5.0 hrs			

Distributed by:

AIR LOCKER INC. (ARB USA)

AUBURN

4810 D St NW #103,
Auburn WA 98001, USA

T +1 425 264 1391

E sales@arbusa.com

W arbusa.com

AIR LOCKER INC. (ARB USA)

JACKSONVILLE

3700 Port Jacksonville Pkwy Suite #1,
Jacksonville FL 32226, USA

T (904) 379 8216

F (904) 813 7197

E sales@arbusa.com

W arbusa.com

ARB OFFROAD LTD

(ARB THAILAND)

Eastern Seaboard Industrial Estate
Building GW 1, 2nd Floor 300/56,
Moo 1, T.Tasit,
A Pluakdaeng
Rayong 21140, Thailand

T +66 38 929 672

E sales.thailand@arb.com.au

W arb.co.th

ARB EUROPE S.R.O

Na Dlouhém č.80,
DC2 251 01

Říčany - Jažlovice
Czech Republic

T +420-323-040-900

E sales@arbeurope.com

W arbeurope.com

ARB MIDDLE EAST FZE

13, N204, JAFZA – (North Zone),
Jebel Ali Freezone,
Dubai, United Arab Emirates

T +971 4 880 7005

E purchasingmena@arb.com.au

W arbmiddleeast.com

ARB NEW ZEALAND

205 Ellis St, Frankton
Hamilton 3204, New Zealand

T +64 7 847 3524

E nzsales@arb.com.au

W arb.co.nz

HEAD OFFICE: ARB 4X4 ACCESSORIES

42-44 Garden Street,
Kilsyth Victoria 3137 Australia

T +61 3 9761 6622 **F** +61 3 9761 6607

E exports@arb.com.au **W** arb.com.au

