

# ARB AIR LOCKER *Air Operated Locking Differentials*

## RD90 TOYOTA 7.5" IFS

### Specs:

Axle Spline	27 tooth, Ø28.0mm [1.10"]
Ratio Supported	All
Ring Gear ID	118.0mm [4.65"]
Ring Gear OD	191mm [7.5"]
Ring Gear Bolts	10 bolts on Ø140mm [5.51"]
Ring Gear Torque	96Nm [71 ft-lb]
Backlash	0.13-0.18mm [0.005-0.007"]
Bearing Cap Torque	85Nm [63 ft-lb]

### Notes:

- 1 For replacement O-rings use only BS148 Viton 75.
- 2 For replacement bearing use Timken part # LM503349 / LM503310.

Spare axle retaining clips may be required (not supplied) to refit CV shafts.

ITEM #	QTY	DESCRIPTION	PART #	NOTES
1	1	BONDED SEAL	160701	
2	1	CLUTCH GEAR	050802	
3	8	RETURN SPRING	150113	
4	1	LONG CROSS SHAFT	061302	
5	1	SPIDER BLOCK	070503	
6	1	DIFFERENTIAL CASE	013101	
7	3	CROSS SHAFT RETAINING PIN	120601	
8	1	TAPERED ROLLER BEARING	NOT SUPPLIED	
9	1	SHIM KIT	SHK008	
10	1	TAPERED ROLLER BEARING	160117	2
11	1	SEAL HOUSING ASSEMBLY	081701	
12	2	SEAL HOUSING O-RING	160233	1
13	1	FLANGE CAP ASSEMBLY	028501	
14	1	SPLINED SIDE GEAR	131602H	
15	4	PINION THRUST WASHER	151112	
16	4	PINION GEAR	140801H	
17	2	SHORT CROSS SHAFT	061402	
18	1	SIDE GEAR	131502H	
19	2	SIDE GEAR THRUST WASHER	151011	
20	2	COUNTERSUNK SCREW	200213	
21	2	ANTI-FRICTION BUSHING (PTFE)	160801	
*	1	AIR LINE (5mm DIA X 6m LONG)	170301	
*	1	BULKHEAD FITTING KIT (O-RING TYPE)	170105	
*	1	PUSH-IN FITTING (5mm to 1/8" BSPP)	170201	
*	1	SOLENOID VALVE (12V)	180103	
*	10	CABLE TIE	180301	
*	1	NIPPLE (1/8" to 1/8" BSPT)	170501	
*	1	SWITCH	180209	
*	1	SWITCH COVER (FRONT)	180210	
*	1	BUMPER STICKER	210102	
*	1	WARNING STICKER	210101	
*	1	OPERATING & SERVICE MANUAL	210200	
*	1	INSTALLATION GUIDE	210290	

\* Not illustrated in exploded view.

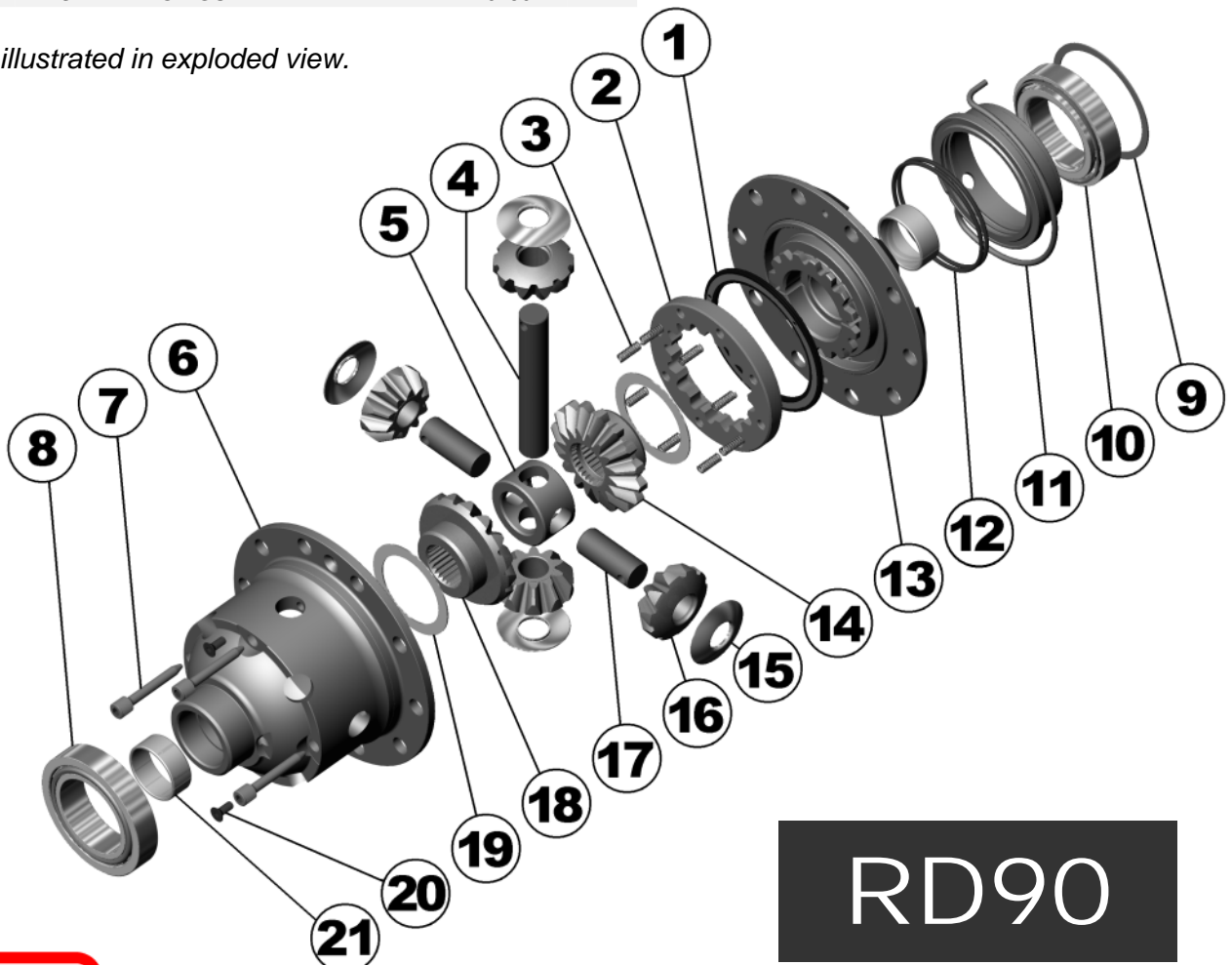

# RD90

